



aerospace
climate control
electromechanical
filtration
fluid & gas handling
hydraulics
pneumatics
process control
sealing & shielding



Gas and Sample Filtration

For Process Gas and On-Line Analysis



ENGINEERING YOUR SUCCESS.

Compressed Air Treatment

Superior protection from the damaging and costly effects of oil, water and dirt...

- Filter elements that offer both market leading performance and efficiency and are environmentally friendly in their manufacture and disposal.
- Housings ranging from 1/4" to DN200" coded vessels, together with a full range of drain and differential pressure gauge options.
- A wide range of filtration efficiencies to provide the exact filtration that's required. From bulk water separation through to bacteria removal for sterile air.
- Innovative membrane air dryers that provide clean dry air with dew points down to -40°C, without any moving parts or the requirement for additional power.
- The inherent advantages of Parker filter elements are available in a range of filter elements sized to fit other manufacturers housings, offering the opportunity to upgrade to a Parker filter.

Gas Filtration

Filtration for sampling systems, analyser applications and process gases providing protection - pure and simple...

- Remove liquids and solids from gases with up to 99.9999+% efficiency at 0.01 µm.
- Specially configured filter media for applications such as carbon dioxide purification, alternative fuels and steam filtration.
- Temperature resistance to 538°C and a maximum pressure of 345 barg.
- Low pressure drop and a long life between filter element changes.

On-Site Nitrogen Generators

Nitrogen is the most widely used gas in industry since it can prevent the risk of explosion or stop product degradation. Nitrogen is being used in new and exciting applications such as tyre filling for cars, motorcycles and trucks...

- Parker's proprietary hollow fibre membrane technology simply and elegantly separates nitrogen from compressed air.
- Generators such as the NitroSource will provide a supply of nitrogen from house compressed air, whilst units such as the Micro provide a plug-and-play solution with the inclusion of an integrated compressor.

Contents

| | |
|---|---|
| Understanding Gas Filtration | 4 |
|---|---|

Filtration Media

| | |
|---|----|
| Depth Filter Media | 6 |
| Stainless Steel Filter Media | 8 |
| Sintered Stainless Steel Filter Media | 9 |
| Membrane Filter Media | 10 |
| Chemical Compatability | 11 |

Housing Selection for Gas and Sample Filtration

| | |
|---|----|
| Gas Flow Rates | 12 |
| Adsorbent Gas and Liquid Flow Rates | 14 |
| Plastic Inline Filters..... | 15 |
| Disposable Inline Filters | 16 |
| Hydrophobic Membrane Filters | 19 |
| Combination Coalescer Membrane Filters | 21 |
| Aluminium Heads and Various Bowls | 23 |
| Miniature T-Model Filter Housings..... | 25 |
| Stainless Steel Inline Filter Housings | 26 |
| Low Internal Volume Filter Housings | 27 |
| High Internal Volume Filter Housings | 28 |
| High Flow Housings for Medium to high Pressure Applications | 29 |
| High Pressure Filter Housings | 30 |
| Fast-Loop Filter Housings..... | 31 |

Filters for Specific Applications

| | |
|--|----|
| Vehicle Emissions Analyser Filters..... | 32 |
| Alternative Fuel | 34 |
| Steam Filters | 35 |
| Liquid Filters | 37 |
| Stainless Steel Filters for Food Processing & Packaging | 42 |

Accessories

| | |
|---|----|
| Stainless Steel Regulators & Filter Regulators..... | 45 |
| High Pressure Drain Kits..... | 46 |

| | |
|-------------------------------|-----------|
| Application Notes..... | 47 |
|-------------------------------|-----------|

| | |
|--|-----------|
| Nitrogen Generators from Parker | 52 |
|--|-----------|

| | |
|---|-----------|
| Global Company Local Support | 53 |
|---|-----------|



Understanding Gas Filtration

The filtration of gases is important in a vast range of applications, yet only three main mechanisms are involved, either on their own, or in combination.

Coalescing

Stack Gas Sampling

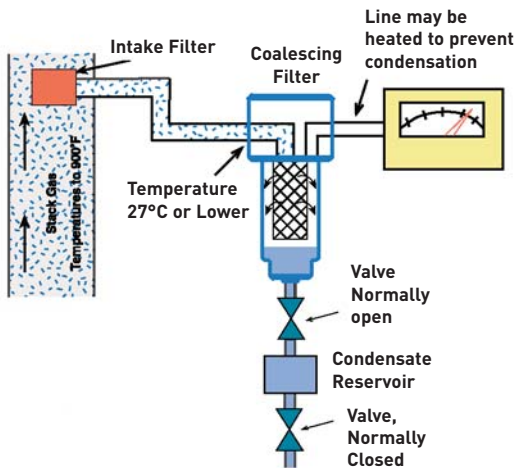

Here, unwanted contaminants in the liquid phase are removed by flowing the gas through the walls of a filter tube, normally constructed as a glass fibre matrix.

Inside to outside flow causes collision between the liquid droplets and the matrix, causing them to coalesce into larger droplets which flow down the outside of the tube to be drained away. If the gas stream contains only liquid contaminants, with no solids present, then the filter tube life is theoretically infinite.

In practice, however, it is the presence of particulates which will cause the eventual increase in the pressure drop across the filter which dictates the filter element's life. It is also important to remember that although liquids are removed as droplets, further condensation can take place downstream of the filter if there is a decrease in temperature. Parker coalescing filters are designed for long life, combining high coalescing efficiency with good particulate handling capacity.

When choosing coalescing filters, it is important to size the housings correctly for the flow and pressure involved. This is to ensure that the housing material is compatible with the gas being filtered, the maximum working pressure to be encountered and the temperature of the gas.



Intercepting - Particulate Removal

Slipstream or By-pass Sampling

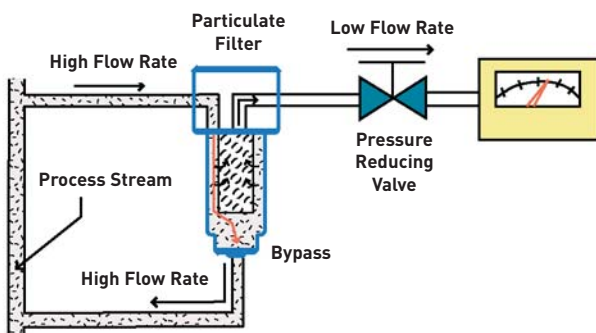

Contaminants in the solid phase are generally removed using combinations of depth or surface filters, often connected in series, starting with coarse particle removal and finishing with fine particle removal. Parker BX grade filters can remove 99.99% of 0.01 micron particles, whilst SA grades can remove 99.9999+%.

Choosing filter media and housings will depend on the anticipated particulate loading, flow, temperature, pressure and the compatibility of the gas with the housings.

For example, Parker model 97S6 model 316 stainless steel housings are rated at pressures up to 345 barg and temperatures up to 204 °C.



Adsorption – Vapour Removal

Air Mixing

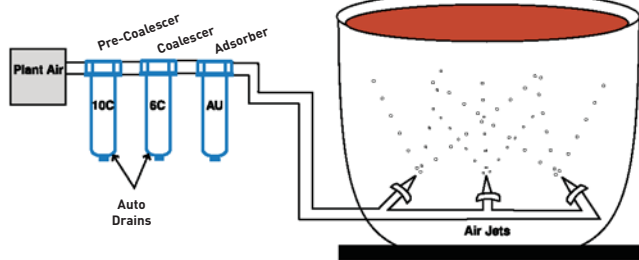

Unwanted vapours in the gas stream can be selectively removed using Parker adsorbant cartridges.

Vapours such as water, hydrocarbons, sulphur compounds and ammonia can all be removed using Parker cartridges specifically developed for the purpose.

The adsorption process can either be physical (as with water vapour removal), or chemical (sulphur compounds and ammonia). In either case, filter cartridge life is directly dependent on the level of vapour contaminants present. Often these are present in trace amounts, resulting in long cartridge life.



Other Separation Mechanisms

Gas Separation Membrane

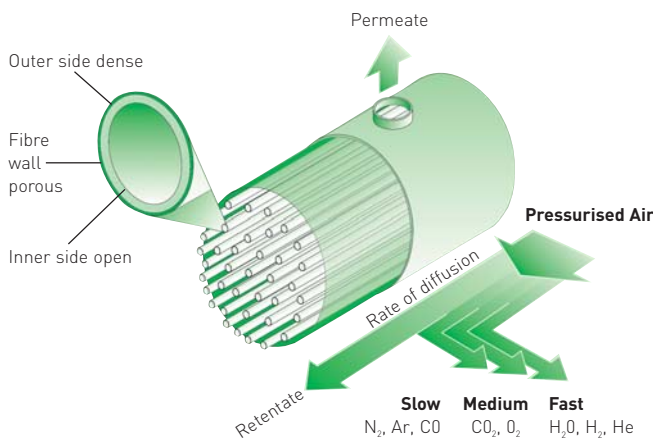

Parker has other useful technologies for gas treatment – generally developed for compressed air. These include drying (dew point suppression) using membrane technology **(see catalogue S3.2.111)**, and membrane gas separation of air into nitrogen and oxygen. **(see catalogue K3.1.075)**



Depth Filter Media

Filter housings used with these media

9922-05; 9933-05; 9922-11; 9933-11; 8833-11; 90; 7700-12; 58P; 53/18; 53/50; 54/50; A98/11; A39/12; 105S6; 91S6; 95M; 95S6; 95A; 95T; 97S6; 30/12; 30/25; 91S6; 31G; 41G; 31S6; 41S6; 33G; 33S6; 45G; 45S6; EU27/35; EU27/35-3000; EU27/80; EU27/80-3000; 15/80S6; EU85; EU37/12; EU37/25; 58N; 38/12; 38/25; A23/75SR; A23/75R; SP3/75SR; SP4-23/75SR; SP6-23/75SR; 6000 series; A34; A33B; A45; A27/35B; A27/80B.

Media Specifications

| | |
|------------------------------|----------------------|
| Microfibre Filter Cartridges | Efficiency at 0.01µm |
| Grades DX, DQ, DH, DS | 93% |
| Grades BX, BQ, BH, BS | 99.99% |
| Grades AQ, AH, AS | 99.9999% |
| Grades AAQ, AAH, AAS | 99.9999+% |

Media Models

X-Model Elements: This new innovation in filter media from Parker reduces the cost of filtration by significantly lowering the pressure drop across the media. Used for solids and relatively large amounts of suspended liquids in gases. Excellent chemical resistance, temperature resistance to 150°C and good mechanical handling properties. These cartridges have thick walls for improved coalescing efficiency. Fluorocarbon resin binder.

Q-Model Elements: Used for solids and small amounts of liquids in gases. Similar to X-Model Cartridges in chemical and temperature resistance. Fluorocarbon resin binder.

H-Model Elements: Recommended for oxygen service temperatures above 290°C or when X-Model or Q-Model are unsuitable. H-Model cartridges have temperature resistance to 480°C in dry gas, 38°C in liquid. Quartz construction.

S-Model Elements: For temperatures above 150°C and below 290°C. Similar in performance to the Q-Model. PTFE binder.

R-Model and SR-Model Elements: For steam filtration, the R-Model is suitable for hospital sterilisers and the SR-Model is used in food industry applications and other applications that require a higher pressure.

GS Membrane Elements: Final filter for low flow in critical applications where 0.01µm filtration is required.

000-Model: Activated carbon adsorber for most C4 and heavier hydrocarbons, ketones, alcohols, ethers, organic acids, chlorinated freons, aromatic hydrocarbons and carbon disulphide.

101-Model: Silica gel adsorber for water vapour

102-Model: 4A molecular sieve adsorber for carbon dioxide, ammonia, sulphur dioxide, hydrogen sulphide, acetylene, propylene, methane, ethane, water vapour, ethylene, ethylene oxide and carbon disulphide.

103-Model: 13X molecular sieve adsorber for all materials adsorbed by - 102 plus: methanol, straight chain mercaptans, freon 11, freon 12, freon 114, sulphur hexafluoride, cyclohexane, diphenyl, butene-1, isopentane, benzene, toluene, xylene, boron trifluoride, triethylamine and smaller amines, straight chain hydrocarbons to C22, alkenes to C4 and acetylene.

105-Model: Calgon HGR adsorber for mercury vapour.

107-Model: Mixed sodium and calcium hydroxides adsorber for all acidic gases, including sulphur dioxide, sulphur trioxide, nitrogen dioxide, carbon dioxide, hydrogen sulphide, sulphur hydrogen chloride, hydrogen chloride.

To calculate the absorbent life of an application, please consult the Parker Technical Support team referencing 'K.3.2.147 - Calculation of Absorbent cartridge'.

Liquid Filtration

| Microfibre Filter Cartridges | (98% retention) | LP Cartridges | (80% retention) |
|------------------------------|-----------------|---------------|-----------------|
| Grades DX, DQ, DH, DS | 25µm | Grade 20 | 25µm |
| Grades BX, BQ, BH, BS | 2µm | Grade 30 | 10µm |
| Grades AQ, AH, AS | 0.9µm | Grade 50 | 1µm |
| Grades AAQ, AAH, AAS | 0.3µm | | |

LP Elements: Designed to filter liquids with high solids content. Have an integral pre-filter and an external support structure (flow direction is inside-to-outside).

Filter housings used with these media

Q1S; Q5S; H1S; H5S; Q15N; Q2N; ILN; IKN; P1N; FFC-116; FFC-112; FFC-112SAE; FFC-110; FFC-110L; FFC-113; FFC-114; FFC-116.

Media Specifications

| Grade Designation | Coalescing Efficiency 0.3 to 0.6 Micron Particles | Coalescing Filters - C, QU, H Oil Maximum Carryover ⁽¹⁾ PPM | Particulate Filters- G, S, T, 3PU Micron Rating | Pressure ⁽⁵⁾ Drop (bar)@Rated Flow Media Dry | Pressure ⁽⁵⁾ Drop (bar)@Rated Flow Media Wet |
|-------------------|---|--|---|---|---|
| AU ⁽²⁾ | 99%+ | N/A | N/A | 0.07 | - |
| 100WS | N/A | N/A | 100N | 0.02 | - |
| 4 | 99.995% | 0.003 | 0.01 | 0.09 | 0.25 |
| 6 | 99.97% | 0.008 | 0.01 | 0.07 | 0.2 |
| 7CVP | 99.5% | 0.09 | 0.5 | 0.02 | 0.04 |
| 10 | 95% | 0.85 | 0.7 | 0.03 | 0.03 |
| 3 PU | N/A | N/A | 3.0 | 0.02 | - |

Notes:

- 1 Tested per BCAS 860900 at 40 ppm inlet.
- 2 Oil vapour removal efficiency is given for AU media.
- 3 Models C, QU and H flow is inside to out. Models G, S, T, 3PU, AU flow is outside to in.
- 4 Grades 2, 4 and 6 are 0.01 micron filters.
- 5 Add dry and Wet for total pressure drop

Media Models

Flow 100WS (C, QU, H, 7CVP) - Inside to Out

- 100WS** Reduction of excess liquids in gas stream. Excellent prefilter for grades 10C and 6C.
- C** Coalescing element composed of an epoxy saturated, borosilicate glass micro-fibre tube with intimate interlocking contact with rigid seamless retainer. Surrounded by a coarse fibre drain layer, retained by a synthetic fabric safety layer replaces epoxy.
- QU** Coalescing element with the same configuration as "C" tube, but with "3P" model pleated cellulose prefilter built-in. Includes molded polyurethane end seals.
- H** Coalescing element similar to model "C" however no rigid retainer is used. Typically for lower pressure or higher temperature applications.
- 7CVP** High efficiency and very low pressure drop makes this pleated coalescing media an excellent choice for medium efficiency applications.

Flow (G, T, 3PU, AU) - Outside to In

- G** Particulate removal element constructed of the same fibre matrix as model "C" but with no rigid retainer or drain layer.
- T** Particulate removal element like "G" tube, except fluorocarbon saturant replaces epoxy
- 3PU** Pleated cellulose particulate removal element. Includes molded polyurethane end seals.
- AU** Hydrocarbon vapour removal element. Ultrafine grained, highly concentrated, activated carbon sheet media. Includes molded polyurethane end seals.



Parker Hannifin (UK) Ltd

Industrial Division, Suite 42, Kent House, Romney Place, Maidstone, Kent ME15 6LH
Tel: +44 (0)1622 772440 Fax +44 (0)1622 772446 E-mail: baststonukinfo@parker.com Web site: www.parker.com

Stainless Steel Mesh Filter Media

Features

Long element life

Re-usable

Rugged element design

All 316 Stainless Steel construction

Temperature to 250°C

Pressure to 345 barg

Three standard efficiency ratings from 1.5 to 15 microns nominal, 5 to 25 microns absolute (others available) and three standard sizes are available. SSC cartridges are re-usable and may be cleaned using back flushing, chemical or ultrasonic methods. Therefore they are especially suited to applications



where solid contamination levels are high. Their rugged construction and resistance to corrosion can be utilised in the most demanding applications, where the filter system is subjected to extremes of pressure and temperature.

Flow Rates

| Air Flow Rates in m ³ /h at indicated line pressure and 0.1 barg pressure drop | | | | | | | | | | | | |
|---|---------------|-------------------|------|------|------|------|-------|-------|---------|---------|---------|--|
| Housing | Element Grade | Air Pressure barg | | | | | | | | | | |
| | | 0.1 | 1 | 2 | 4 | 7 | 10 | 16 | 100 | 200 | 340 | |
| 95S6 85 | 03 | 2.5 | 4.5 | 6.7 | 11.0 | 18.0 | 25.0 | 38.0 | 225.0 | 450.1 | 765.1 | |
| | 10 | 5.1 | 9.3 | 14.0 | 23.0 | 37.0 | 51.0 | 79.0 | 470.0 | 940.1 | 1,590.1 | |
| | 25 | 6.1 | 11.0 | 17.0 | 28.0 | 45.0 | 61.0 | 95.0 | 560.0 | 1,120.1 | 1,900.1 | |
| 33S6 37/12 33G | 03 | 4.8 | 9.0 | 13.0 | 22.0 | 35.0 | 48.0 | 75.0 | 440.0 | 880.1 | | |
| | 10 | 8.5 | 16.0 | 23.0 | 39.0 | 62.0 | 85.0 | 130 | 780.0 | 1,560.1 | | |
| | 25 | 10.0 | 18.0 | 27.0 | 44.0 | 71.0 | 97.0 | 150.0 | 890.1 | 1,780.1 | | |
| 45S6 37/25 45G | 03 | 9.0 | 17.0 | 25.0 | 42.0 | 67.0 | 92.0 | 140.0 | 840.1 | 1,680.1 | | |
| | 10 | 11.0 | 20.0 | 30.0 | 49.0 | 79.0 | 110.0 | 170.0 | 990.1 | 1,980.1 | | |
| | 25 | 12.0 | 21.0 | 32.0 | 53.0 | 84.0 | 115.0 | 180.0 | 1,060.1 | 2,120.2 | | |

Principal Specifications

| Cartridge Code | SSC-050-11-XX | SSC-100-12-XX | SSC-100-25-XX |
|---|---------------|---------------|---------------|
| Material of Construction | 316 SS | 316 SS | 316 SS |
| Seals | Viton | Viton | Viton |
| Maximum Differential Pressure barg ⁽²⁾ | 10 | 10 | 10 |
| Maximum Differential Pressure barg ⁽³⁾ | 1 | 1 | 1 |

Gas Filtration Efficiency

| Micron Rating Code | 100% Retention µm size | 98% Retention µm size |
|--------------------|------------------------|-----------------------|
| -03 | 5 | 1.5 |
| -10 | 12 | 5 |
| -25 | 25 | 15 |

Water Filtration Efficiency

| Micron Rating Code | 100% Retention µm size | 98% Retention µm size |
|--------------------|------------------------|-----------------------|
| -03 | 9 | 3 |
| -10 | 20 | 10 |
| -25 | 35 | 25 |

Ordering Information

SSC Filter Cartridges are specially designed to fit Balston stainless steel housings to give an all stainless steel filter system.

| Cartridge Code Fits | Housing Codes |
|---------------------|--------------------|
| SSC-050-11-XX | 95S6; 85 |
| SSC-100-12-XX | EU37/12; 33S6; 33G |
| SSC-100-25-XX | EU37/25; 45S6; 45G |

Notes:

1 Alternative seals in PTFE are available. Contact Technical Support

2 Out-to-In flow 3 In-to-Out flow e.g. when back flushing

Viton[®] is a registered trademark of DuPont Dow Elastomers.

Stainless Steel Sintered Metal Filter

Features

Remove solids and liquids from gas samples

Remove solids from liquid samples

Filtration efficiencies from 5-100 micron

316L stainless steel construction

Long life, cleanable filter cartridges

Temperature resistance to 200°C

Up to 14 barg (differential pressure)

Advantages

The Parker stainless steel sintered metal filter is suitable for applications which require a durable, low maintenance re-usable stainless steel filter. The filter cartridge is constructed of 316 stainless steel with two molded viton gaskets. It may be installed in select Parker filter housings



that are designed to accommodate a 050-11, 100-12 or 100-25 size filter cartridge. Parker stainless steel sintered metal filters may be used in liquid or gas service, to filter particulate sized from 5 micron to 100 micron - depending on the grade of the filter used. The Parker stainless steel sintered metal filter has excellent chemical resistance characteristics.

Flow Rates (m³/h)

| Filter Housing Model | Filter Size | Filter Cartridge Grade | Max Porosity (Micron) | 0.3 barg | 1.3 barg | 2.8 barg | 4.1 barg | 5.5 barg | 6.9 barg | 8.6 barg | 11.0 barg | 13.8 barg | 17.2 barg | 20.7 barg | 34.5 barg |
|--|-------------|------------------------|-----------------------|----------|----------|----------|----------|----------|----------|----------|-----------|-----------|-----------|----------------|-----------|
| 95 85 Series 91 | 050-11 | 05M | 5 | 1.4 | 2.7 | 4.4 | 6.1 | 7.5 | 9.2 | 11.2 | 13.3 | 17.0 | 20.4 | 25.5 | 40.8 |
| | | 10M | 10 | 2.0 | 4.1 | 6.6 | 9.2 | 11.2 | 13.8 | 16.8 | 20.4 | 25.5 | 32.3 | 37.4 | 61.2 |
| | | 20M | 20 | 1.6 | 3.2 | 5.2 | 7.2 | 8.8 | 11 | 13 | 16 | 20 | 25 | 30 | 48 |
| | | 40M | 40 | 4.1 | 8.2 | 13.3 | 18.7 | 22.1 | 27.2 | 34.0 | 39.1 | 52.7 | 62.9 | 74.8 | 124.0 |
| | | 70M | 70 | 5.8 | 11.6 | 18.7 | 25.5 | 32.3 | 39.1 | 47.6 | 56.1 | 73.1 | 90.0 | 107.0 | 175.0 |
| | | 00M | 100 | 7.5 | 15.0 | 23.8 | 34.0 | 40.8 | 51.0 | 61.2 | 73.1 | 95.1 | 115.5 | 137.6 | 226.0 |
| 31S6 33S6 31G 33G | 100-12 | 05M | 5 | 4.1 | 8.8 | 13.6 | 18.7 | 23.8 | 28.9 | 35.7 | 40.8 | 54.4 | 66.3 | 79.9 | 129.1 |
| | | 10M | 10 | 6.1 | 13.3 | 20.4 | 28.9 | 35.7 | 44.2 | 52.7 | 62.9 | 81.6 | 117.2 | 118.9 | 193.7 |
| | | 20M | 20 | 8.2 | 17.0 | 27.2 | 37.4 | 47.6 | 57.8 | 70.0 | 83.3 | 108.7 | 132.5 | 158.0 | 258.2 |
| | | 40M | 40 | 12.2 | 27.2 | 40.8 | 56.1 | 71.4 | 86.6 | 105.3 | 124.0 | 161.4 | 200.5 | 237.9 | 389.1 |
| | | 70M | 70 | 17.0 | 37.4 | 57.8 | 79.9 | 101.9 | 122.3 | 149.5 | 176.7 | 229.4 | 283.7 | 336.4 | 550.5 |
| | | 00M | 100 | 22.1 | 49.3 | 74.8 | 103.6 | 130.8 | 159.7 | 192.0 | 227.7 | 297.3 | 367.0 | 434.9 | 711.9 |
| 41S6 45S6 41G 45G 37/25 | 100-25 | 05M | 5 | 5.8 | 12.2 | 18.7 | 27.2 | 34.0 | 40.8 | 49.3 | 57.8 | 76.5 | 93.4 | 112.1 | 183.5 |
| | | 10M | 10 | 8.7 | 17.7 | 28.9 | 39.1 | 51.0 | 61.2 | 74.8 | 88.3 | 115.5 | 141.0 | 168.2 | 273.5 |
| | | 20M | 20 | 11.6 | 23.8 | 39.1 | 52.7 | 68.0 | 81.6 | 98.5 | 117.2 | 152.9 | 188.6 | 224.3 | 365.3 |
| | | 40M | 40 | 17.0 | 37.4 | 57.8 | 79.9 | 100.2 | 122.3 | 149.5 | 175.0 | 229.4 | 282.0 | 334.7 | 548.8 |
| | | 70M | 70 | 23.8 | 52.7 | 81.6 | 112.1 | 142.7 | 173.3 | 210.7 | 248.1 | 324.5 | 399.3 | 475.7 | 776.4 |
| | | 00M | 100 | 32.3 | 68.0 | 107.0 | 146.1 | 185.2 | 224.3 | 237.5 | 321.1 | 421.4 | 518.2 | 615.0, 1,005.8 | |

Principal Specifications

| | | |
|----------------------------------|--|---------------------------------------|
| Filter Efficiency | 5 micron to 100 micron (nominal) in gas and liquid | Dimensions (including gaskets) |
| Materials of Construction | 316L Stainless Steel Cartridge, Viton Gasket | 050-11 size 19 x 58 mm |
| Maximum Temperature | 200°C | 100-12 size 31 x 63 mm |
| Maximum Pressure Drop | 14 barg | 100-25 size 31 x 177 mm |
| | | Shipping Weight 0.2 kg |

Ordering Information

| | 050-11 Size | 100-12 Size | 100-25 Size | |
|----------------------------------|-------------|-------------|-------------|----------------------------|
| Sintered Metal Filter | 050-11-() | 100-12-() | 100-25-() | Example: 100-12-40M |
| Replacement Viton Gaskets | A05-0045 | A05-0046 | A05-0047 | |

Viton® is a registered trade mark of DuPont Dow Elastomers.



Parker Hannifin (UK) Ltd

Industrial Division, Suite 42, Kent House, Romney Place, Maidstone, Kent ME15 6LH

Tel: +44 (0)1622 772440 Fax +44 (0)1622 772446 E-mail: baststonukinfo@parker.com Web site: www.parker.com

Membrane Filter Media

0.01 µm Membrane Filters

The GS Membrane Cartridges represent state-of-the-art membrane filtration technology. An integral pre-filter, bonded to a porous PTFE membrane, provides the user with extended membrane life, 0.01µm filtration rating and, most importantly, zero fibre shedding. The Balston GS Membrane filter also offers excellent chemical compatibility as a result of the inert materials of construction. All of these features combine to make the Balston GS cartridges the ideal choice for critical process gas filtration requirements.



Retention Efficiency

A staff research scientist at M.I.T., Dr. McCarthy used a submicron particle detection and sizing device to collect and analyse the filter efficiency data. The test procedure consisted of challenging the membrane filter with a sodium chloride aerosol solution, which contained aerosol particles in a narrowly defined size range. Downstream from the filter, the effluent gas was evaluated for particulate contaminant size using a condensation nucleus counter. There was no detectable penetration of 0.01 µm particles through the membrane filters. Bulletin TI-834 details the efficiency rating procedure and experimental results of this study.

GS Membrane cartridges physical properties, Temperature Range: -40°C to 121°C

Maximum pressure differential across membrane, Inside-to-outside flow: 4.1 bar (size code 050), 1.4 bar (size code 100 and 200)

Materials of construction: Borosilicate glass with fluorocarbon resin binder pre-filter and PTFE membrane

Retention efficiency: 0.01 µm

Chemical Compatibility

The GS Series Membrane Filter cartridges are compatible with the following gases (when installed in a stainless steel filter housing with Teflon seals).

| | | |
|-------------------------------|-------------------|------------------|
| Ammonia | Air (Compressed) | Argon |
| Arsine | Boron Trichloride | Carbon Dioxide |
| Carbon Tetrafluoride | Chlorine (dry) | Diborane |
| Dichlorosilane | Fluorine (dry) | Freon |
| Helium | Hydrogen | Hydrogen Bromide |
| Methylene Chloride | Nitrogen | Nitrous Oxide |
| Phosphorous Oxychloride (dry) | Phosphine | Silane |

Ordering Information

| Model | No. Required | Box of 3 | Box of 10 |
|------------|--------------|----------------|--------------|
| 97S6 | 1 | GS-3/050-05-95 | GS-050-05-95 |
| 91S6 | 1 | GS-3/050-11-95 | GS-050-11-95 |
| 95S6 | 1 | GS-3/050-11-95 | GS-050-11-95 |
| 95T | 1 | GS-3/050-11-95 | GS-050-11-95 |
| 31S6, 33S6 | 1 | GS-3/100-12-95 | GS-100-12-95 |
| 41S6, 45S6 | 1 | GS-3/100-25-95 | GS-100-25-95 |

Chemical Compatibility and Application Index

| Chemical | X-Model or Q-Model with Fluorocarbon Resin Binder | H-Model with Quartz Construction | LP Cartridge with Polypropylene Support |
|--|--|----------------------------------|---|
| Cold Water | Excellent | Fair | Excellent |
| Hot Water (to 820°C) | Excellent | Not Recommended | Not Recommended |
| Steam (to 1-4 barg) | Excellent | Not Recommended | Not Recommended |
| Acids <i>(except Hydrofluoric)</i> | Dilute Concentrations Excellent | Excellent | Excellent |
| | Intermediate concentrations Excellent | Excellent | Good |
| | Concentrated <i>(except Phosphoric)</i> Good-Fair | Excellent | Not Recommended |
| | Concentrated Phosphoric Hydrofluoric Not Recommended | Not Recommended | Not Recommended |
| Caustic, below 45% | Excellent | Not Recommended | Fair |
| Caustic, above 45% | Fair | Not Recommended | Not Recommended |
| Chlorine <i>(liquid or gas)</i> | Excellent | Excellent | Not Recommended |
| Ammonia <i>(liquid or gas)</i> | Not Recommended | Not Recommended | Fair |
| Aromatic Hydrocarbons | Excellent | Excellent | Good |
| All other Hydrocarbons | Excellent | Excellent | Excellent |
| Ketones | Not Recommended | Excellent | Fair |
| Alcohols | Excellent | Excellent | Excellent |
| Freons | Excellent | Excellent | Not Recommended |
| Phenol | Excellent | Excellent | Not Recommended |
| Chlorinated Solvents | Excellent | Excellent | Fair |
| Ethylene Diamine | Excellent | Excellent | Not Recommended |
| Ethanolamine | Not Recommended | Excellent | Not Recommended |
| Other Amines | Good-Fair | Excellent | Not Recommended |
| Polar Solvents <i>(including: DMF, DMAC, NMP, DMSO)</i> | Not Recommended | Excellent | Not Recommended |

| Operating Requirement | Filter Cartridge Model | Stainless Steel (or Monel) Housing | Plastic Housing |
|--|------------------------|---|------------------------------|
| Pressure 176 To 340 barg | All | 91S6, 97S6, 95M, 85, EU37/12, EU37/25, EU27/35, EU27/80, 95S6 | - |
| Temperature 150° to 290°C | S, H | Any stainless steel or Monel housing with Viton seals | - |
| Temperature 290° to 480°C | H | 30/12, 30/25 | - |
| Exceptional Chemical Resistance | see above | 95M | 9922-□-□, 8822-□-□, 95T |
| NACE Compliance | All | 95S6, 85, EU37/12, EU37/25, EU27/35, EU27/80 | - |
| Separate Liquids From Gases | X, Q | All housings except 97S6, 30/12, 30/25 | 8822-11-□, 8833-11-□, 95T |
| Remove Gas Bubbles From Liquids | X, Q | All housings except 97S6, 30/12, 30/25 | 8822-11-□, 95T |
| Quantitative Measurement Of Solids In Gases | H, Q, S | 30/12, 30/25 | - |
| Slipstream Or By-pass Filtration | X, Q, LP, S | All housings except 97S6, 30/12, 30/25 | 8822-11-□, 95T, 53/18, 53/50 |
| Filter Liquids With High Solids Content | LP | All housings | All housings |
| Filter Gas Or Liquid Samples To Analysers | X, Q, LP, S | All housings | 9933-05-□, 9922-05-□, 90 |

Gas Flow Rates

| Filter Housing | Page | Volume of Housing (ml) | Filter Element Grade | Flow Rates, m ³ /h, At 0.14 Drop At Indicated Line Pressure, barg. | | | | | | | | | | |
|-----------------|------|------------------------|----------------------|---|-------|-------|--------|--------|--------|--------|--------|--------|--------|--|
| | | | | 0.14 | 1.4 | 3 | 4 | 6 | 7 | 9 | 10 | 14 | 17 | |
| 9922-05 | 16 | 15 | DQ | 2.0 | 4.2 | 6.6 | 9.1 | 11.6 | 14.1 | 17.2 | | | | |
| 9933-05 | | | BQ | 1.4 | 2.7 | 4.4 | 5.9 | 7.6 | 9.2 | 11.2 | | | | |
| | | | GS | 0.8 | 1.7 | | 2.5 | | 3.4 | 3.7 | | | | |
| 8822-11 | 16 | 52 | DX | 3.1 | 6.1 | 10.2 | 13.6 | 17.0 | 20.4 | 24.8 | | | | |
| 8833-11 | | | | | | | | | | | | | | |
| 9933-11 | 16 | 35 | BX | 1.5 | 3.1 | 5.1 | 6.8 | 8.5 | 10.2 | 12.4 | | | | |
| 9922-11 | | | GS | 0.8 | 1.7 | | 2.9 | | 3.7 | 3.9 | | | | |
| 97S6 | 26 | 16 | DQ | 5.1 | 11.9 | 17.0 | 23.8 | 30.6 | 37.4 | 45.9 | 54.4 | 69.7 | 86.6 | |
| | | | BQ | 1.5 | 3.1 | 5.1 | 6.8 | 8.5 | 10.2 | 11.9 | 15.3 | 18.7 | 23.8 | |
| 95M | 25 | 25 | DQ | 6.6 | 13.6 | 22.1 | 30.6 | 37.4 | 45.9 | 56.1 | 66.3 | 86.6 | 105.3 | |
| 95S6 | | | | | | | | | | | | | | |
| 95T | | | BQ | 2.6 | 5.1 | 8.5 | 11.9 | 13.6 | 17.0 | 20.4 | 23.8 | 32.3 | 39.1 | |
| 91S6 | 26/ | 38 | | | | | | | | | | | | |
| 47S6 | 27 | | GS | 0.8 | 1.7 | | 3.1 | | 4.2 | 4.8 | 5.1 | 5.8 | | |
| 48S6 | 31 | 23 | DQ | 4.2 | 17.0 | 27.2 | 39.1 | 47.6 | 56.1 | 68.0 | 79.9 | 103.6 | 127.4 | |
| | | | BQ | 3.4 | 8.5 | 13.6 | 15.3 | 17.0 | 18.7 | 22.1 | 27.2 | 34.0 | 42.5 | |
| 85 | 30 | 53 | DX | 10.0 | 20.4 | 33.1 | 44.2 | 54.4 | 69.7 | 84.9 | 98.5 | 129.1 | 156.3 | |
| | | | BX | 3.7 | 7.8 | 13.1 | 14.7 | 20.4 | 25.5 | 30.6 | 37.4 | 47.6 | 57.8 | |
| 31S6 | 27 | 132 | DQ / DX | 17.0 | 37.4 | 59.5 | 81.5 | 103.6 | 125.7 | 152.9 | 181.8 | 237.8 | 292.2 | |
| 31G | | | BQ / BX | 3.4 | 10.2 | 15.3 | 20.4 | 27.2 | 34.0 | 40.8 | 49.3 | 62.9 | 78.1 | |
| | | | GS | 1.7 | 3.6 | | 7.8 | | 11.9 | 13.1 | 14.3 | 16.3 | | |
| 33S6 | 28 | 204 | DX | 20.4 | 44.2 | 68.0 | 93.4 | 118.9 | 144.4 | 175.0 | 207.3 | 270.1 | 333.0 | |
| 33G | | | | | | | | | | | | | | |
| EU37/12 | 30 | 171 | BX | 5.1 | 11.9 | 17.0 | 23.8 | 30.6 | 37.4 | 45.9 | 54.4 | 69.7 | 86.6 | |
| 30/12 | | 107 | GS | 1.7 | 3.6 | | 7.8 | | 11.9 | 13.1 | 14.3 | 16.3 | | |
| 49S6 | 31 | 165 | DQ | 22.1 | 47.6 | 76.5 | 103.6 | 132.5 | 159.7 | 195.4 | 229.4 | 300.7 | 370.4 | |
| | | | BQ | 10.2 | 22.1 | 35.7 | 47.6 | 59.5 | 73.1 | 90.0 | 105.3 | 137.6 | 169.9 | |
| 41S6 | 27 | 285 | DQ / DX | 25.5 | 54.4 | 84.9 | 117.2 | 147.8 | 180.1 | 219.2 | 258.2 | 338.1 | 416.2 | |
| | | | BQ / BX | 11.9 | 25.5 | 40.8 | 54.4 | 69.0 | 84.9 | 103.6 | 122.3 | 158.0 | 195.0 | |
| 41G | | | GS | 5.1 | 10.2 | | 22.1 | | 34.0 | 37.4 | 40.8 | 46.6 | | |
| 30/25 | | 260 | DQ / DX | 28.9 | 61.2 | 96.8 | 132.5 | 168.2 | 203.9 | 248.0 | 292.2 | 382.2 | 470.6 | |
| 45S6 | 28 | 455 | | | | | | | | | | | | |
| 45G | 28 | 455 | BQ / BX | 13.6 | 28.9 | 44.2 | 61.2 | 76.4 | 93.4 | 113.8 | 134.2 | 175.0 | 215.8 | |
| EU37/25 | 30 | 328 | GS | 5.1 | 10.2 | | 22.1 | | 34.0 | 37.4 | 40.8 | 46.6 | | |
| EU27/35 | 29 | 1,867 | DX | 68.0 | 141.0 | 220.8 | 302.4 | 382.2 | 463.8 | 564.0 | 665.9 | 866.4 | 1068.6 | |
| | | | BX | 32.3 | 66.3 | 105.3 | 142.7 | 181.8 | 219.2 | 266.7 | 314.3 | 409.4 | 504.6 | |
| EU27/80 | 29 | 3311 | DX | 73.1 | 152.9 | 241.2 | 327.9 | 416.2 | 504.6 | 615.0 | 723.7 | 942.9 | 1162.0 | |
| | | | BX | 47.6 | 100.2 | 158.0 | 215.8 | 273.5 | 331.3 | 402.6 | 475.7 | 620.1 | 762.8 | |
| 15/80S6 | 29 | 4700 | DX | 271.8 | 565.8 | 892.0 | 1218.2 | 1542.7 | 1868.9 | 2276.7 | 2684.4 | 3500.0 | 4315.5 | |
| | | | BX | 76.5 | 159.7 | 251.5 | 343.2 | 434.9 | 526.7 | 642.2 | 756.1 | 985.4 | 1214.8 | |
| Q1S,Q5S,H1S,H5S | 40 | | 4 | 1.3 | 2.9 | 4.6 | 6.2 | 7.8 | 9.5 | 11.6 | 13.6 | 17.8 | 21.9 | |
| | | | 6 | 1.8 | 3.9 | 6.1 | 8.2 | 10.5 | 12.7 | 15.4 | 18.2 | 23.8 | 29.2 | |
| | 24 | | 10 | 3.1 | 6.7 | 10.6 | 14.2 | 18.1 | 22.0 | 26.7 | 31.5 | 41.2 | 50.7 | |
| | | | AU | 1.8 | 3.9 | 6.1 | 8.2 | 10.5 | 12.7 | 15.4 | 18.2 | 23.8 | 29.2 | |
| Q15N,Q2N | 23 | | 2 | 4 | 5.0 | 10.9 | 17.2 | 23.0 | 29.3 | 35.6 | 43.3 | | | |
| | | | 6 | 6.7 | 14.5 | 23.0 | 30.8 | 39.2 | 47.6 | 57.9 | | | | |
| | | | 10 | 12.9 | 28.0 | 44.2 | 59.3 | 75.5 | 91.7 | 111.5 | | | | |
| | | | AU | 6.7 | 14.5 | 23.0 | 30.8 | 39.2 | 47.6 | 57.9 | | | | |
| FFC-110 | 34 | 148 | 10 | 6.0 | 13.0 | 20.5 | 27.5 | 35.0 | 42.5 | 51.6 | 60.8 | 79.6 | 97.8 | |
| FFC-110L | 34 | 207 | 6 | 12.0 | 25.9 | 41.0 | 55.0 | 70.0 | 85.0 | 103.3 | 121.6 | 159.2 | 195.8 | |
| FFC-112 | 34 | 14.8 | 10 | 3.6 | 7.8 | 12.3 | 16.5 | 21.0 | 25.5 | 30.9 | 36.4 | 47.7 | 58.6 | |
| FFC-112SAE | 34 | 14.8 | 10 | 3.6 | 7.8 | 12.3 | 16.5 | 21.0 | 25.5 | 30.9 | 36.4 | 47.7 | 58.6 | |
| FFC-113 | 34 | 14.8 | 6 | 12.0 | 25.9 | 41.0 | 55.0 | 70.0 | 85.0 | 103.3 | 121.6 | 159.2 | 195.8 | |
| FFC-114 | 34 | 89 | 10 | 12.0 | 25.9 | 41.0 | 55.0 | 70.0 | 85.0 | 103.3 | 121.6 | 159.2 | 195.8 | |
| FFC-116 | 34 | 7.4 | 10 | 2.0 | 4.3 | 6.8 | 9.1 | 11.5 | 14.0 | 17.0 | 20.0 | 26.2 | 32.2 | |
| ILN/IKN | 15 | 40 | 4 | 1.1 | 2.4 | 3.8 | | | | | | | | |
| | | | 6 | 1.5 | 3.2 | 5.0 | | | | | | | | |
| | | | 10 | 2.0 | 4.4 | 7.0 | | | | | | | | |
| A33B-SA | 44 | | SA | | 13.62 | 18.66 | 27.18 | 35.7 | 42.48 | 52.68 | 61.14 | | | |
| A45B-SA | 44 | | SA | | 32.28 | 50.94 | 69.66 | 86.64 | 107.58 | 129.12 | 152.88 | | | |
| A27/35B-SA | 44 | | SA | | | 39.06 | 62.88 | 84.96 | 108.72 | 130.86 | 159.72 | 188.58 | | |
| A27/80B-SA | 44 | | SA | | | 78.12 | 125.7 | 171.6 | 219.12 | 263.34 | 321.06 | 378.84 | | |
| P1N | 24 | 210 | 2 | | 7 | 10 | | 14 | | | | | | |
| | | | 4 | | 10 | 14 | | 19 | | | | | | |
| | | | 6 | | 14 | 19 | | 26 | | | | | | |
| | | | 8 | | 17 | 22 | | 29 | | | | | | |
| | | | 10 | | 20 | 26 | | 34 | | | | | | |

| Refer to Product specification Charts For Maximum Pressure of Each Housing | | | | | | | | | | | | Filter Housing |
|--|--------|--------|--------|--------|--------|---------|---------|--------|--------|--------|---------|--|
| 21 | 35 | 52 | 69 | 103 | 138 | 172 | 207 | 241 | 276 | 310 | 345 | |
| | | | | | | | | | | | | 9922-05 9933-05 |
| | | | | | | | | | | | | 8822-11 8833-11 9933-11 9922-11 |
| 101.9 | 168.2 | 249.7 | 331.3 | 492.7 | 655.8 | 818.8 | 981.9 | 1145.0 | 1308.1 | 1505.2 | 1634.3 | 97S6 |
| 27.2 | 44.2 | 66.3 | 88.3 | 130.8 | 175.0 | 217.5 | 261.6 | 304.1 | 348.3 | 390.7 | 434.9 | |
| 125.7 | 205.6 | 305.8 | 406.0 | 606.5 | 798.5 | 1002.3 | 1206.2 | 1410.0 | 1596.9 | 1800.8 | 2004.6 | 95M 95S6 95T |
| 45.9 | 76.4 | 113.8 | 149.5 | 224.2 | 305.8 | 373.7 | 441.7 | 526.6 | 594.0 | 662.6 | 747.5 | 91S6 47S6 |
| 7.0 | 9.0 | | 12.6 | | 17.8 | | 21.9 | | 25.1 | | 28.0 | 48S6 |
| 151.2 | 246.4 | 356.8 | 475.7 | 713.6 | 951.4 | 1189.3 | 1427.2 | 1665.0 | 1902.9 | 2140.8 | 2378.6 | |
| 49.3 | 78.2 | 118.9 | 152.9 | 220.9 | 305.8 | 373.8 | 441.7 | 509.7 | 577.7 | 645.6 | 713.6 | |
| 188.6 | 309.2 | 458.7 | 611.6 | 917.4 | 1206.2 | 1512.0 | 1809.3 | 2115.1 | 2412.4 | 2718.1 | 3006.9 | 85 |
| 69.7 | 115.5 | 192.0 | 227.6 | 339.8 | 450.2 | 552.1 | 679.5 | 807.0 | 900.4 | 1002.3 | 1121.2 | |
| 348.3 | | | | | | | | | | | | 31S6 31G |
| 91.7 | | | | | | | | | | | | |
| 19.7 | | | | | | | | | | | | |
| 395.3 | 647.3 | 963.2 | 1277.5 | 1906.1 | 2536.4 | 3164.9 | 3795.2 | 4417.0 | 5045.6 | | | 33S6 33G |
| 101.9 | 168.2 | 249.7 | 331.3 | 494.4 | 657.5 | 820.5 | 983.6 | 1180.7 | 1308.1 | | | EU37/12 |
| 19.7 | 25.1 | | 35.3 | | 49.8 | | 61.0 | | 70.3 | | | 30/12 |
| 440.0 | 718.7 | 1068.7 | 1417.0 | 2115.3 | | | | | | | | 49S6 |
| 202.2 | 329.6 | 489.3 | 650.7 | 970.1 | | | | | | | | |
| 494.4 | | | | | | | | | | | | 41S6 |
| 236.1 | | | | | | | | | | | | 41G |
| 558.9 | 914.0 | 1359.0 | 1804.2 | 2693.0 | 3581.2 | 4469.6 | 5361.5 | 6251.7 | 7135.1 | | | 30/25 |
| | | | | | | | | | | | | 45S6 |
| 256.5 | 419.6 | 623.5 | 827.3 | 1235.1 | 1642.8 | 2050.5 | 2982.0 | 2871.0 | 3278.8 | | | 45G |
| 56.2 | 72.0 | | 101.1 | | 142.4 | | 173.3 | | 200.5 | | EU37/25 | |
| 1270.7 | 2072.6 | 3091.9 | 4094.2 | 6115.8 | 8120.5 | 10142.1 | 12163.7 | | | | | EU27/35 |
| 599.7 | 981.9 | 1457.6 | 1936.7 | 2888.0 | 3839.4 | 4790.7 | 5747.1 | | | | | |
| 1382.9 | 2259.5 | 3363.7 | | | | | | | | | | EU27/80 |
| 907.2 | 1483.1 | 2208.5 | | | | | | | | | | |
| 5131.0 | 8393.1 | | | | | | | | | | | 15/80S6 |
| 1444.2 | 2361.6 | | | | | | | | | | | |
| | | | | | | | | | | | | Q1S, Q5S, H1S, H5S |
| | | | | | | | | | | | | Q15N, Q2N |
| | | | | | | | | | | | | |
| 116.6 | 190.7 | | | | | | | | | | | FFC-110 |
| 233.4 | 381.7 | | | | | | | | | | | FFC-110L |
| 69.9 | 114.3 | 169.6 | 225.0 | 336.0 | 447.0 | 558.1 | 668.8 | 779.8 | | | | FFC-112 |
| 69.9 | 114.3 | 169.6 | 225.0 | 336.0 | 447.0 | 558.1 | 668.8 | 779.8 | | | | FFC-112-SAE |
| 233.4 | 381.7 | 566.6 | 751.4 | | | | | | | | | FFC-113 |
| 233.4 | 381.7 | 566.6 | 751.4 | | | | | | | | | FFC-114 |
| 38.4 | 62.9 | 93.3 | 123.8 | 184.8 | 245.9 | 307.0 | 367.9 | 429.0 | 490.0 | 551.1 | 612.0 | FFC-116 |
| | | | | | | | | | | | | ILN/IKN |
| | | | | | | | | | | | | A33B-SA |
| | | | | | | | | | | | | A45B-SA |
| | | | | | | | | | | | | A27/35B-SA |
| | | | | | | | | | | | | A27/80B-SA |
| | | | | | | | | | | | | P1N |



Adsorbent Cartridge Flow Rates of Gas⁽¹⁾ (m³/h)

| Housing | Grade | Flow Rates in m ³ /hr (A.N.R.) ⁽²⁾ at 0.14 barg Pressure Drop Indicated Line Pressure | | | | | | | | | | | | |
|--------------------|-------|---|------|-------|-------|-------|-------|-------|-------|-------|-------|-------|-------|-------|
| | | 0.14 | 1 | 2 | 4 | 6 | 10 | 15 | 20 | 30 | 50 | 70 | 100 | 150 |
| 9922-05, 9933-05 | DAU | 0.9 | 1.7 | 2.5 | 4.3 | 6.1 | - | - | - | - | - | - | - | - |
| 9922-11, 9933-11 | | | | | | | | | | | | | | |
| 8822-11, 8833-11 | DAU | 1.3 | 2.4 | 3.5 | 5.7 | 7.9 | - | - | - | - | - | - | - | - |
| 33S6, 33G, EU37/12 | CI | 3.7 | 6.1 | 9.3 | 15.9 | 22.3 | 35.3 | 51.7 | 67.8 | 100.8 | 165.6 | 231 | 328.8 | 491.4 |
| 45S6, 45G, EU37/25 | CI | 10.2 | 17.1 | 25.4 | 42.1 | 58.8 | 92.4 | 133.8 | 175.8 | 259.2 | 426 | 592.8 | 840 | 1260 |
| EU27/35 | CI | 20.4 | 36 | 53.2 | 87.6 | 122.4 | 191.4 | 277.2 | 363.6 | 535.8 | 882 | - | - | - |
| EU27/80 | CI | 39.1 | 92.4 | 123.6 | 186.6 | 249.6 | 376.2 | 533.4 | 690 | 1008 | 1638 | - | - | - |

Notes:

- 1 Please see Page 12/13 for coalescing filter flow rates.
- 2 A.N.R. = Standard reference Atmosphere (1000mbar, 20°C 65% R.H.)

Note: Housings should be checked for individual pressure ratings.

To calculate the adsorbent life of an application, please consult the Parker Technical Support team referencing 'K.3.2.147 - Calculation of Adsorbent cartridge'.

Flow Rates for Liquid Filters

| Filter Housing | Volume of Housing Litres | Initial Pressure Drop bar | O or X Cartridges | | Water Flow Rate, litres per minute | | | |
|---|--------------------------|---------------------------|-------------------|--------|------------------------------------|----------|----------|----------|
| | | | DQ, DX | BQ, BX | Grade 10 | Grade 20 | Grade 30 | Grade 50 |
| Stainless Steel, Monel and Teflon Housings | | | | | | | | |
| 105S6 | - | 0.07 | 0.44 | 0.13 | - | - | - | - |
| | - | 0.34 | 1.51 | 0.63 | - | - | - | - |
| 48S6 | - | 0.07 | 0.88 | 0.25 | - | - | - | - |
| | - | 0.34 | 3.22 | 1.32 | - | - | - | - |
| 95M, 95S6, 95T, 95A | 0.02 | 0.07 | 1.14 | 0.32 | - | - | - | - |
| 91S6, 47S6 | 0.04 | - | - | - | - | - | - | - |
| 85 | 0.06 | 0.34 | 4.04 | 1.64 | - | - | - | - |
| 31S6, 31G | 0.10 | 0.07 | 3.41 | 0.82 | - | - | - | - |
| | 0.10 | 0.34 | 8.14 | 3.53 | - | - | - | - |
| 49S6 | - | 0.07 | 3.60 | 0.88 | - | - | - | - |
| | - | 0.34 | 8.52 | 3.79 | - | - | - | - |
| 33S6, 33G, EU37/12 | 0.16 | 0.07 | 3.97 | 1.01 | 3.15 | 3.15 | 2.52 | 0.63 |
| | 0.16 | 0.34 | 9.46 | 4.16 | 13.25 | 13.25 | 11.36 | 2.84 |
| 41S6, 41G | 0.19 | 0.07 | 5.99 | 1.89 | - | - | - | - |
| | 0.19 | 0.34 | 16.40 | 7.63 | - | - | - | - |
| EU37/25, 45S6, 45G | 0.42 | 0.07 | 6.88 | 2.21 | 4.73 | 4.73 | 3.79 | 0.95 |
| | 0.42 | 0.34 | 18.93 | 8.83 | 18.93 | 18.93 | 16.40 | 4.10 |
| EU27/35 | 1.49 | 0.07 | 20.50 | 5.68 | - | - | - | - |
| | 1.49 | 0.34 | 55.20 | 25.24 | - | - | - | - |
| EU27/50 | - | 0.07 | - | - | 13.25 | 13.25 | 13.25 | 5.05 |
| | - | 0.34 | - | - | 45.42 | 45.42 | 45.42 | 24.61 |
| EU27/80 | 2.84 | 0.07 | 24.61 | 10.73 | - | - | - | - |
| | 2.84 | 0.34 | 62.46 | 38.49 | - | - | - | - |
| EU27/95 | - | 0.07 | - | - | 26.50 | 26.50 | 26.50 | 10.09 |
| | - | 0.34 | - | - | 90.85 | 90.85 | 90.85 | 49.21 |
| 15/80S6 (2) | - | 0.07 | 104.10 | 45.42 | - | - | - | - |
| | - | 0.34 | 252.36 | 157.73 | - | - | - | - |
| Plastic Housings | | | | | | | | |
| 9922-05, 9933-05 | 0.01 | 0.07 | 0.76 | 0.19 | - | - | - | - |
| | 0.01 | 0.34 | 1.89 | 0.95 | - | - | - | - |
| 8822-11, 8833-11, 9922-11, 9933-11 | 0.02 | 0.07 | 1.14 | 0.32 | - | - | - | - |
| | 0.02 | 0.34 | 2.84 | 1.64 | - | - | - | - |
| 90 | - | 0.07 | 1.45 | 0.63 | - | - | - | - |
| | - | 0.34 | 2.90 | 2.27 | - | - | - | - |
| 7700-12, 58P | 0.13 | 0.07 | - | - | 3.15 | 3.15 | 2.52 | 0.63 |
| | 0.13 | 0.34 | - | - | 13.25 | 13.25 | 11.36 | 2.84 |
| 53/18 | 0.70 | 0.07 | - | - | 6.31 | 6.31 | 6.31 | 2.52 |
| | 0.70 | 0.34 | - | - | 22.71 | 22.71 | 22.71 | 11.99 |
| 53/50, 54/50 | 0.70 | 0.07 | - | - | 6.31 | 6.31 | 6.31 | 2.52 |
| | 0.70 | 0.34 | - | - | 22.71 | 22.71 | 22.71 | 11.99 |
| 53/95 | 2.50 | 0.07 | - | - | 26.50 | 26.50 | 26.50 | 10.09 |
| | 2.50 | 0.34 | - | - | 90.85 | 90.85 | 90.85 | 49.21 |

Notes:

- 1 For liquids with viscosity higher than the viscosity of water [1 centipoise], divide the flow rates in the above table by the viscosity of the liquid in centipoises.
- 2 Flow rates for Model 15/80S6 are estimated.

Plastic Inline Filters

Features

Pre and fine filtration in one unit

Pressure ratings up to 3.4 barg

Temperature to 52°C

Twist-lock design

The ILN/IKN inlines are used for low flow circuit protection on sensing instruments, analysers, air-logic, and other control devices. High efficiency coalescing and particulate elements are available.

This twist-lock plastic housing is designed for 3.45 bar maximum operating pressure. The two-stage filter design allows for high efficiency element replacement and the re-use of the 75-micron prefilter.



ILN/IKN Series

Principal Specifications

| | ILN/IKN | ILND/IKND | ILNV/IKNV |
|----------------------------------|---|---|---|
| Port Size | 1/8" | 1/8" | 1/8" |
| Maximum Pressure | 3.4 barg | 3.4 barg | 3.4 barg |
| Materials of Construction | | | |
| Head | ILN: Nylon IKN Clear Polyurethane | ILND: Nylon IKND Clear Polyurethane | ILNV: Nylon IKNV Clear Polyurethane |
| Internals | Neoprene | Neoprene | Neoprene |
| Bowl | ILN: Nylon IKN Clear Polyurethane | ILND: Nylon IKN Clear Polyurethane | ILNV: Nylon IKN Clear Polyurethane |
| Seals | Silicone Rubber | Silicone Rubber | Silicone Rubber |
| Shipping Weight | 0.05kg | 0.05kg | 0.05kg |
| Dimensions | 46x102mm | 46x102mm | 46x102mm |

Ordering Information

| I | | N | | — | | | 05-011 |
|--|--|---|--|---|--------------|------------------|--------------|
| Port Size | | Model of Drain | | | Media Grade | Media Model | Element Size |
| L = 1/8" NPT K = 1/8" NPT with brass inserts | | blank for no drain; closed D = Open; constant bleed drain V = Valved; manual drain | | | 4 6 10 | G T F H | |

For Example: IKND-4G05-011 for complete assembly, including element. IKND x 1 for an empty housing.



Parker Hannifin (UK) Ltd

Industrial Division, Suite 42, Kent House, Romney Place, Maidstone, Kent ME15 6LH

Tel: +44 (0)1622 772440 Fax +44 (0)1622 772446 E-mail: baststonukinfo@parker.com Web site: www.parker.com

Disposable Inline Filters

Features

Prevent cross-contamination of samples

Pressure ratings up to 8.5 barg

Temperature to 135°C

Completely disposable, constructed of recyclable plastics



Models 9922-05, 9933-05, and 9900-05

The 9933-03 models are the smallest disposable filter units with 6.6ml internal volume. These models are used in low flow gas or liquid sampling applications, such as liquids to specific-ion analysers or gases to personal samplers. The model 9900-05-BK has a colour indicating feature, which turns the cartridge red when saturated with oil.

Models 9922-11 and 9933-11

Models 9922-11 and 9933-11 are used for applications similar to the smaller DFUs (Models 9922-05 and 9933-05), which require greater solids holding capacity and can tolerate the increased retention time.

Model 8833-11

These disposable filter units are used as continuous coalescing filters with a third port serving as the drain, slipstream, or by-pass port.

Principal Specifications

| Model | 8822-11 | 8833-11 | 9922-05 | 9933-03 | 9933-05 | 9922-11 | 9933-11 |
|--|-------------|---------------|-------------|---------------|---------------|-------------|---------------|
| Inlet and Outlet Ports | 1/4" Tubing | 1/4" Tubing | 1/4" Tubing | 1/4" Tubing | 1/4" Tubing | 1/4" Tubing | 1/4" Tubing |
| Drain | 1/4" Tubing | 1/4" Tubing | None | None | None | None | None |
| Material of Construction | PVDF (Blue) | Nylon (Clear) | PVDF (Blue) | Nylon (Clear) | Nylon (Clear) | PVDF (Blue) | Nylon (Clear) |
| Filter Cartridge Length | 57mm | 57mm | 32mm | 32mm | 32mm | 57mm | 57mm |
| Maximum Temperature⁽¹⁾ | 135°C | 110°C | 135°C | 110°C | 110°C | 135°C | 110°C |
| Maximum Pressure⁽²⁾ | 8.5 barg | 8.5 barg | 8.5 barg | 8.6 barg | 8.1 barg | 8.5 barg | 8.5 barg |
| Dimensions | 36 x 120mm | 36 x 120mm | 25 x 80mm | 25 x 44mm | 25 x 80mm | 36 x 120mm | 36 x 120mm |

Ordering Information

| Model | 8822-11 | 8833-11 | 9922-05 | 9933-03 | 9933-05 | 9922-11 | 9933-11 |
|-----------------------------|-----------|-----------|-----------|------------|------------|-----------|-----------|
| Box 10 | 8822-11-□ | 8833-11-□ | 9922-05-□ | 9933-03-□ | 9933-05-□ | 9922-11-□ | 9933-11-□ |
| Available only in | X-grades | X-grades | Q-grades | Q-grades | Q-grades | Q-grades | Q-grades |
| Box 10 DAU'S ⁽³⁾ | | N/A | 9922-05-□ | 9933-03-□ | 9933-05-□ | 9922-11-□ | 9933-11-□ |
| 0.01 membrane filters | | | | 9933-05-95 | 9922-11-95 | | |

Notes:

1 At 0 barg

2 At 43°C

3 To designate adsorbent in the DAU, insert adsorbent numbers after DAU designation. For example, to obtain a miniature clear nylon DAU with carbon adsorbent, order 9933-05-000. Adsorbent numbers are listed on page 6

Model 8800-12

Large Capacity Disposable Adsorption Filters

Proven to be the best performing filters, Parker Balston has introduced a new line of disposable in-line adsorption filters, the model 8800-12. This filter is designed to remove vapours from gases. Vapours such as hydrocarbons, ketones, carbon dioxide, ammonia, mercury, methane, ethylene, methanol, freons, acidic gases, and water vapour are just a few of a long list of vapours that can be adsorbed. In addition, several of the models can be used in liquid service to remove trace contaminants.

The filters are capable of handling up to 3.5 barg operating pressures in gas service and up to 4.8 barg in liquid service.

The units come standard with 1/2" tube connections and are constructed of durable nylon.

These filters are ideal for sample analyzing, venting applications, emissions monitoring, direct food contact applications and other applications critical to vapour contamination.

Our years of experience in fitting products to individual applications has led to the creation of a variety of standard products that can be ordered off the shelf. If you require a specific configuration, size, or material, our Engineering Team will be happy to work closely with you and design product to your exact specifications.



Ideal for the following gas filtration applications:

- Final filter for air logic devices
- Protection of pneumatic components
- Filtration of portable environmental sampling devices
- Filtration of samples to on-line analysers
- Protection of pneumatic temperature controls

Ideal for the following liquid filtration applications:

- Filtration of liquid with minimum hold-up volume
- Filtration of liquid samples to analysers

Additional applications in the following industries:

- Instrument and Controls
- HVAC
- Dental
- Emissions Monitoring
- Food Packaging
- Ambient Air Monitors



Parker Hannifin (UK) Ltd

Industrial Division, Suite 42, Kent House, Romney Place, Maidstone, Kent ME15 6LH

Tel: +44 (0)1622 772440 Fax +44 (0)1622 772446 E-mail: baststonukinfo@parker.com Web site: www.parker.com

Disposable Adsorption Units (DAU) contain a bed of adsorbent granules. Utilizing a wide choice of adsorbents, the DAUs selectively remove vapours from air and other gases.

Because the adsorbed vapour remains trapped in the solid bed, the DAU has a fixed upper Limit of total weight of vapour which can be captured. It is usually not feasible to regenerate the filter when it has reached its adsorption Limit. DAUs should be used only when small quantities of vapour are to be removed.

Considerations in Using Adsorbent Cartridges

The following factors should be considered when selecting a DAU:

- 1 Solid adsorbents are effective only for vapours. Since Liquids will damage or inactivate most solid adsorbents, the DAU must be preceded by an efficient coalescing filter.
- 2 In contrast with Microfibre Filters, which operate at their initial efficiency throughout their Life, adsorbent cartridges have a limited holding capacity. When the adsorption capacity is reached, no further adsorption occurs. The limiting capacity, or "breakthrough" point, is not sharply defined, and the exit vapour concentration will increase

rapidly as saturation is approached. To avoid unwanted vapour contaminants downstream, it is necessary to change the adsorbent cartridge well before it has reached its ultimate adsorption capacity.

- 3 Adsorption is reversible, if operating conditions change, a vapour may desorb rather than adsorb. For example, if a temporary surge in vapour impurity concentration causes a relatively high concentration to be adsorbed on the solid, a subsequent decrease in inlet vapour composition will result in desorption of vapour from the solid to the gas stream.
- 4 The efficiency of a given adsorbent for a given vapour depends upon the specific operating conditions. Therefore, again in contrast to filtration, it is not possible to assign a single efficiency rating to an adsorbent. While it is not possible to predict or guarantee an adsorption efficiency for any specific set of conditions, it is possible to enhance the conditions beneficial to adsorption and avoid conditions which interfere with adsorption. Conditions which aid adsorption are: low temperature, high pressure, low flow rate, and absence of competing vapors [particularly water vapor].

| Adsorbent | Grade | Use For |
|-------------------------------------|-------|---|
| Carbon | 000 | Compressor oil vapours, C ₅ and heavier hydrocarbons, aromatics, oxygenated hydrocarbons, chlorinated organics, freons, carbon disulfide. |
| Silica Gel | 101 | Recommended only for water vapour. |
| Molecular Sieve Type 13X | 103 | Most C ₂ and lighter hydrocarbons, ethylene, propylene, acetylene, ethylene oxide, ammonia, mercaptans, sulphur hexafluoride, triethylamine, and smatter amines. |
| Mixed Sodium and Calcium Hydroxides | 107 | All acidic gases, including sulphur trioxide, sulphur dioxide, nitrogen dioxide, carbon dioxide, hydrogen sulphide, hydrogen chloride, phosphorus trichloride, boron trifluoride. |

Notes:

1. Please refer to Ordering Information for complete explanation of nomenclature.
2. In DAU 8800-12-107, color indicator turns violet when adsorbent is spent.
3. In DAU 8800-12-101, adsorbent turns pink when vapour capacity is reached.
4. Maximum operating temperature is 180°F.

Chemical Compatibility Model 8800-12

Suitable: Water to 70°C (158°F); benzene, toluene, other aromatic hydrocarbons; hydrocarbon solvents and fuels. perchloroethylene; trichloroethylene, nitric acid (to 10%); sulphuric acid (to 40%); hydrochloric acid (to 10%); most salt solutions; sodium and potassium hydroxide (to 50%).

Limited Use: Water at 80°C (176°F); acetone; MEK, acetaldehyde; ammonia (to 25%).

Unsuitable: Water above 70°C (158°F); alcohols; glycols, phenol; aniline; DMF; concentrated acids; chlorine.

| Flow Rates | m ³ /hr @ 0.14 barg DP | | | | |
|-----------------------|-----------------------------------|----------|---------|---------|----------|
| | 10" H2O | 0.14barg | 1.4barg | 2.8barg | 3.5 barg |
| 8800-12-0000 | 0.4 | 1.9 | 8.2 | 11 | 7.33 |
| 8800-12-101, 103, 107 | 0.7 | 23.6 | 10.2 | 13.6 | 15.3 |

Principal Specifications

| | |
|------------------------------------|----------------------------------|
| Model | 8800-12-000, 101, 103, 107 |
| Inlet and Outlet Ports | 1/2" Tubing |
| Drain | None |
| Material of Construction | Nylon |
| Filter Cartridge Length | 2.5" (5.71cm) |
| Maximum Temperature ⁽¹⁾ | 150°F (66°C) |
| Maximum Pressure ⁽²⁾ | 3.5barg |
| Dimensions | 5.69cmD x 15.85cmL (2.24"x6.24") |

Ordering Information

| | |
|-----------------------------|-------------|
| Model | 8800-12 |
| Box of 1 DFU ⁽³⁾ | 8800-12-XXX |

Notes:

1. At 0 barg
2. At 43°C (110°F)
3. To designate adsorbent in the DAU, insert adsorbent numbers after DAU designation. For example, to obtain a miniature clear nylon DAU with carbon adsorbent, order 8800-12-000.

Hydrophobic Membrane Filters

Features

Ideal for protecting all models of on-line analyser

Removes entrained water, submicron sulphuric acid aerosol and ultra fine particulate

Provides an absolute barrier to liquids



MODEL 39

Series 39 and 98 Membrane Filters

The series 39 and 98 membrane filters consist of a housing with a porous PTFE membrane filter, which is supported by a sintered porous disk located on the "outlet" side of the housing. Gas enters through the "inlet" port on the upstream side of the membrane and exits from the "outlet" port on the downstream side. Entrained liquid will not flow through the membrane and will exit through the "by-pass" port on the upstream side of the membrane, completely protecting sensitive instrumentation from moisture.

For the membrane to operate correctly there must be by-pass flow.



MODEL 98

The Membrane

Microscopic pores contained within the membrane permit molecules of gas or vapour to flow through easily, allowing the composition of the sample gas to remain unchanged. Conversely, even the smallest liquid molecules remain trapped and are unable to flow through the membrane's small passages under normal operating conditions. This is due to the high surface tension, which causes liquid molecules to bind tightly together, to form a group of molecules, which is too large to fit through the pores of the membrane. The membrane is extremely inert and is recommended for most process applications, with the exception of hydrofluoric acid. It is also recommended for use in systems designed for ppb, ppm and "percent level" component concentrations, as a result of its very low absorption characteristics. The membrane is strong and durable, but also very soft and pliable.

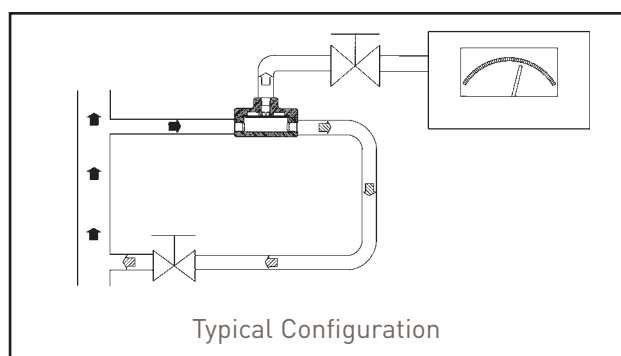

Hydrophobic Membrane Filters

**Flow Rate Vs Pressure Drop
Standard Membrane**

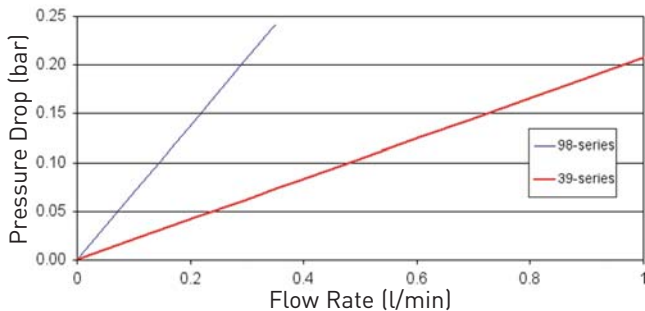

**Flow Rate Vs Pressure Drop
High Flow Membrane**

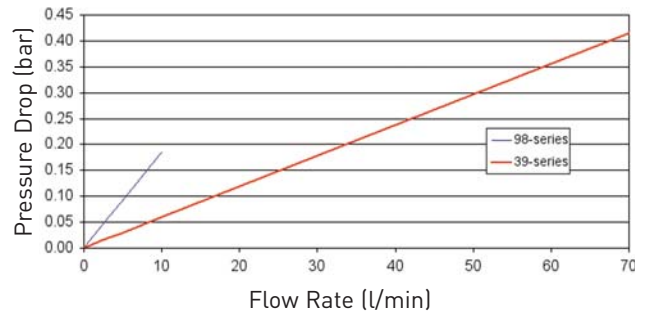

Housing and Membrane Selection Guide

| Model | 39-0 | 39-2 | 98-0 | 98-2 |
|---|-------------------------|--------------------------|-------------------------|--------------------------|
| Membrane Model | Standard ⁽¹⁾ | High Flow ⁽²⁾ | Standard ⁽¹⁾ | High Flow ⁽²⁾ |
| Maximum Recommended Flow Rate in l/min ⁽³⁾ | 1.0 | 70 | 0.6 | 10 |
| Normal Amount of Liquid Present in Gas ⁽⁴⁾ | Low | Low to Medium | Low to Medium | Low to Medium |

- Notes:**
- Standard membrane is suitable for most liquids.
 - High flow membrane is suitable for water, solutions consisting primarily of water, sulphuric acid, caustic, glycols, oily liquids and other high surface tension model liquids.
 - Maximum recommended flow rate of gas through the membrane. Does not include the "by-pass" flow rate.
 - Amount of liquid normally expected to be present in the sample gas: Low: aerosol or occasional droplets. Medium: continuous droplets. High: continuous flowing liquid.

Principal Specifications

| Model | 39 Series | 98 Series |
|---|---|--|
| By-pass Ports | 1/2" NPT | 1/4" NPT |
| Sample Port | 1/4" NPT | 1/4" NPT |
| Materials of Construction | | |
| Housing | 316 Stainless Steel | 316 Stainless Steel |
| O-rings | Viton (standard) Kalrez, Buna, EPDM (optional) | Viton (standard) Kalrez, Buna, EPDM (optional) |
| Maximum Operating Pressure | 29 barg @ 93°C | 69 barg |
| Maximum Temperature | 100°C | 100°C |
| Maximum Recommended Flow Rate | | |
| Standard Membrane | 1 l/min | 0.6 l/min |
| High Flow Membrane | 70 l/min | 10 l/min |
| Typical Membrane Pressure Drop ⁽¹⁾ | | |
| Standard Membrane | 0.07 barg per 250 cc/min flow through membrane | 0.07 barg per 100 cc/min flow through membrane |
| High Flow Membrane | 0.07 barg per 20 litres/min flow through membrane | 0.07 barg per 3.8 litres/min flow through membrane |
| Outside Dimensions | 84 x 51mm | 50 x 50mm |
| Shipping Weight | 1 kg | 0.7kg |

Ordering Information

| Filter Assembly | 39-0 (Standard) | 39-2 (High Flow) | 98-0 (Standard) | 98-2 (High Flow) |
|------------------------------------|-----------------|------------------|-----------------|------------------|
| Maintenance Kits | | | | |
| 5 each Membranes and Viton O-Rings | 39014 | 39015 | 98014 | 98015 |
| 5 each Membranes | 39002 | 39020 | 98002 | 98020 |

- Notes:**
- Pressure Drops are for temperatures to 100°C. Viton® is a registered trademark of DuPont Dow Elastomers.

Combination Coalescer Membrane Filters

Features

Continuous coalescing of all liquid and the security of hydrophobic membrane protection in one unit

Less maintenance and downtime as the membrane is fully protected from solids and liquids

Fewer fittings required — reducing risk of leaks

More compact — no need for separate coalescers

A39/12 & A98 Series Coalescer Membrane Combination Filters

The Balston Coalescer Membrane Combination Filter is designed to remove entrained liquid and particulate in gas samples for a wide variety of applications and thereby prevents contamination or damage to the analysers and sample system components. Typically located upstream of the analyser or component it is protecting; the Coalescer Membrane Combination provides protection even if other sample system components fail. The Coalescer Membrane combination offers the performance and protection of the Balston Membrane Filters, with the additional benefits of liquid coalescing and fine particle capture. There is no need for prefiltration, which places more volume in the sample system, requires more space for installation and has the potential for more areas to leak. The A98 Series and A39/12 Series consists of a housing with a porous membrane filter that is supported by a sintered porous disc located on the "outlet" side of the housing. Gas enters through the "inlet" port and is directed down through the coalescing filter. The coalescer traps all particulates and continuously drains liquid contaminants. The sample gas then flows upward through the membrane and exits from the "outlet" port on the downstream side.

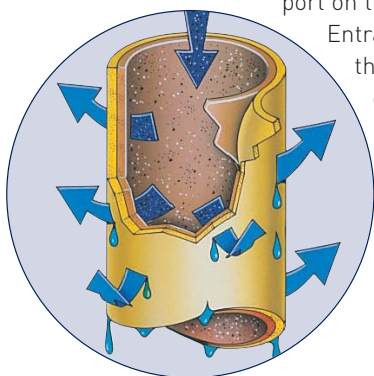

Parker's Coalescing Action

Entrained liquid will not flow through the membrane and exits through the drain port on the downstream side of the coalescer.

For the membrane to operate correctly there must be by-pass flow.



MODEL A39/12



MODEL A98

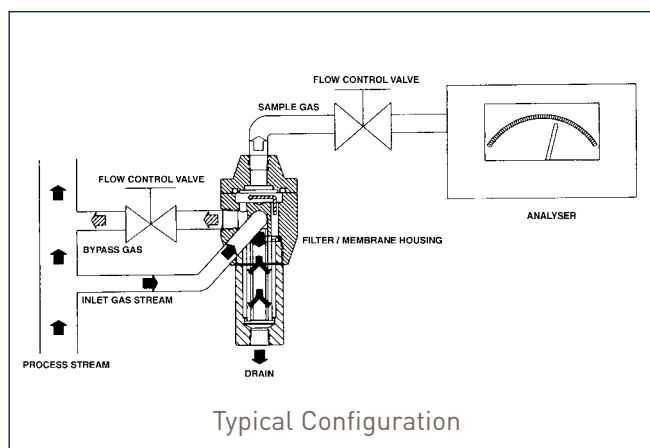

Typical Configuration

The Membrane

Microscopic pores contained within the PTFE membrane permit molecules of gas or vapour to flow through easily, allowing the composition of the sample gas to remain unchanged. Conversely, even the smallest liquid molecules remain trapped and are unable to flow through the membrane's small passages under normal operating conditions. This is due to the high surface tension, which causes liquid molecules to bind tightly together, to form a group of molecules, moving together, which is too large to fit through the pores of the membrane. The membrane is extremely inert and is recommended for most process liquid applications, with the exception of hydrofluoric acid. It is also recommended for use in systems designed for ppb, ppm and "percent level" component concentrations, as a result of its very low absorption characteristics. The membrane is strong and durable, but also very soft and pliable.

Combination Coalescer Membrane Filters

**Flow Rate Vs Pressure Drop
Standard Membrane**

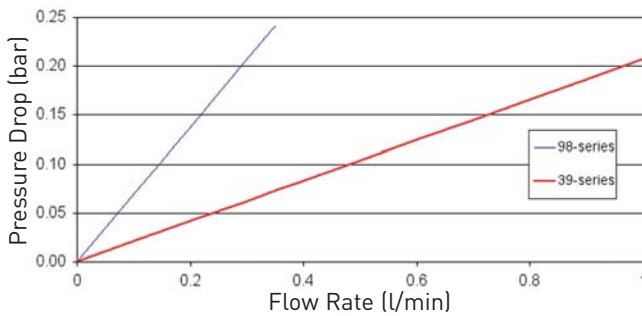

**Flow Rate Vs Pressure Drop
High Flow Membrane**

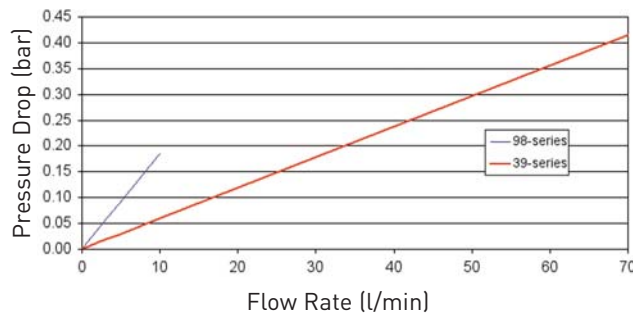

Housing and Membrane Selection Guide

| Model | A39-0 | A39-2 | A98-0 | A98-2 |
|--|-------------------------|--------------------------|-------------------------|--------------------------|
| Membrane Model | Standard ⁽¹⁾ | High Flow ⁽²⁾ | Standard ⁽¹⁾ | High Flow ⁽²⁾ |
| Maximum Recommended Flow Rate in l/min ⁽³⁾ | 1.0 | 70 | 0.6 | 10 |
| Normal Amount of Liquid Present in Gas ⁽⁴⁾ | Low | Low to Medium | Low to Medium | Low to Medium |

- Notes:**
- Standard membrane is suitable for most liquids.
 - High flow membrane is suitable for water, solutions consisting primarily of water, sulphuric acid, caustic, glycols, oily liquids and other high surface tension model liquids.
 - Maximum recommended flow rate of gas through the membrane. Does not include the "by-pass" flow rate.
 - Amount of liquid normally expected to be present in the sample gas: Low: aerosol or occasional droplets. Medium: continuous droplets. High: continuous flowing liquid.

Principal Specifications

| Model | A39/12 Series | A98 Series |
|--|---|--|
| By-pass Ports | 1/2" NPT | 1/4" NPT |
| Sample Ports | 1/4" NPT | 1/4" NPT |
| Materials of Construction | | |
| Housing | 316 Stainless Steel | 316 Stainless Steel |
| O-rings | Viton (standard) Kalrez, Buna, EPDM (optional) | Viton (standard) Kalrez, Buna, EPDM (optional) |
| Maximum Temperature | 100°C | 100°C |
| Maximum Pressure | 29 barg | 69 barg |
| Maximum Flow Rate | Standard Membrane 1 l/min High Flow Membrane 70 l/min | Standard Membrane 0.60 l/min High Flow Membrane 10 l/min |
| Typical Membrane Pressure Drop ⁽¹⁾ | Standard Membrane 0.07 barg per 250 cc/min flow through membrane High Flow Membrane 0.07 barg per 20 l/min flow through the membrane | Standard Membrane 0.07 barg per 100 cc/min flow through membrane High Flow Membrane 0.07 barg per 3.8 l/min flow through the membrane |
| Outline Dimensions | 84 x 185mm | 50 x 100mm |
| Shipping Weight | 1.1 kg | 1.8kg |

Ordering Information

| Filter Assembly A98/11-__Q-0 A98/11-__Q-2 | Filter Assembly A39/12-__X-0, A39/12-__X-2 |
|---|--|
| 98011 5 ea. DQ Filters, Viton O-Rings and Membranes for A98-0 | 39014 5 ea. Viton O-Rings and Membranes for A39/12-0 |
| 98012 5 ea. BQ Filters, Viton O-Rings and Membranes for A98-2 | 39015 5 ea. Viton O-Rings and Membranes for A39/12-2 |
| 98013 5 ea. DQ Filters, Viton O-Rings and Membranes for A98-2 | 39002 5 ea. Membranes for A39/12-0 |
| 98010 5 ea. BQ Filters, Viton O-Rings and Membranes for A98-0 | 39020 5 ea. Membranes for A39/12-2 |
| 98002 5 ea. Membranes for A98-0 | 150-12-□ X 10 ea. Coalescing Filter Cartridges |
| 98020 5 ea. Membranes for A98-2 | |
| 050-11-□ Q 10 ea. Coalescing Filter Cartridges | |

- Notes:**
- For Glass Bowl version order: A39/12G-Q-[0]-[2]
- Viton® is a registered trademark of DuPont Dow Elastomers.

Filters with Aluminium Heads and Various Bowls

Features

Lightweight and economical

Pressure up to 9 barg

Aluminium heads

The Q series is an excellent point-of-use filter where element visibility is required. Coalescing, particulate and adsorption elements are available.

The Q series consists of aluminium head and clear bowl design. Porting in NPT and BSPF is standard with an operating pressure to 9 barg.



QN15N/Q2N Series

Principal Specifications

| | Q_1N | Q_15N | Q_2N |
|----------------------------------|-----------------------------------|-----------------------------------|-----------------------------------|
| Port Size | 1/4" | 3/8" | 1/2" |
| Maximum Pressure | 9 barg | 9 barg | 9 barg |
| Maximum Temperature | 52°C | 52°C | 52°C |
| Materials of Construction | | | |
| Head | Aluminium | Aluminium | Aluminium |
| Internals | Stainless Steel Acetal Plastic | Stainless Steel Acetal Plastic | Stainless Steel Acetal Plastic |
| Bowl | Clear Polyurethane | Clear Polyurethane | Clear Polyurethane |
| Seals | Buna-N | Buna-N | Buna-N |
| Shipping Weight | 0.39 kg | 0.39 kg | 0.39 kg |

Ordering Information

| QN | | | | | |
|-----------|------------|----------------------|-------------|-------------------------------------|--|
| Port Size | Port Model | Media Grade | Media Model | Accessories | |
| 1 = 1/4" | N NPT | blank for 3PU, AU | G | N = None | |
| 15 = 3/8" | F BSPF | 4 | T | D = Differential Pressure Indicator | |
| 2 = 1/2" | | 6 | F | G = Differential Pressure Gauge | |
| | | 8 | H | | |
| | | 10 | C | | |
| | | | CU | | |
| | | | QU | | |
| | | | 3PU | | |
| | | | AU | | |

Note: Although the element size is not included in the part number construction for this filter, the size, 10-025, is needed to order replacement elements. For example, 6C10-025 x 8.

For Example: QN15N-10QU for complete assembly, including element. QN15NN x 1 for an empty housing.



Parker Hannifin (UK) Ltd

Industrial Division, Suite 42, Kent House, Romney Place, Maidstone, Kent ME15 6LH

Tel: +44 (0)1622 772440 Fax +44 (0)1622 772446 E-mail: baststonukinfo@parker.com Web site: www.parker.com

Filters with Aluminium Heads and Various Bowls

Features

Lightweight and economical

Pressure up to 17 barg

Aluminium and plastic heads

The H5S/Q5S series filters are an excellent choice for instrumentation and point-of-use general air system filtration. They also provide coalescing and adsorption filtration for robotic and OEM machine manufacturers.

The P1N offers economical high efficiency filtration for point of use. Instrument systems, or CEM machine circuit protection. The P1N is also used when sump and element visibility are required.

The P1N series consists of acetal plastic head and clear polyurethane bowl design. Porting in NPT with an operating pressure to 7 barg / 100 psi.



H5S/H1S/Q5S/Q1S Series

Principal Specifications

| Model | Q5S | Q1S | H5S | H1S | P1N |
|----------------------------------|---------------|---------------|-----------|-----------|---------------------------------|
| Port Size (NPT) | 1/8" | 1/4" | 1/8" | 1/4" | 1/4" |
| Maximum Pressure | 10 barg | 10 barg | 17 barg | 17 barg | 7 barg |
| Maximum Temperature | 52°C | 52°C | 79°C | 79°C | 52°C |
| Materials of Construction | | | | | |
| Head | Aluminium | Aluminium | Aluminium | Aluminium | Acetal Plastic |
| Bowl | Polycarbonate | Polycarbonate | Zinc | Zinc | Clear Polyurethane |
| Internals | N/A | N/A | N/A | N/A | Acetal Plastic, Stainless Steel |
| Seals | Buna N | Buna N | Buna N | Buna N | Buna N |
| Shipping Weight | 0.1kg | 0.1kg | 0.14kg | 0.14kg | 0.22kg |

Ordering Information

| Drain Option | Port Size | Media Grade | Media Model | Element Size |
|------------------------------|------------------------------|--------------|-------------|--------------|
| blank for manual twist drain | 5 = 1/8" NPT 1 = 1/4" NPT | Blank for AM | HM AM | |
| A =Auto Drain | | 4 | | |
| F =1/8" ID Hose Barb | | 6 | | |
| V =Needle Valve | | 10 | | |

For Example: H5S-6HM06-013 for complete assembly, including element. H5S x 1 for an empty housing.

| Media Grade | Media Model | Element Size |
|----------------------|---|--------------|
| Blank for 3PU and AU | G T F H C CU QU 3PU AU | |
| 4 | | |
| 6 | | |
| 10 | | |

For Example: P1N-4QU10-025 for complete assembly, including element. P1N x 1 for an empty housing.

| Drain Option | Port Size | Media Grade | Media Model | Element Size |
|------------------------------|------------------------------|--------------|-------------|--------------|
| Blank for manual twist drain | 5 = 1/8" NPT 1 = 1/4" NPT | Blank for AM | HM AM | |
| A = Auto Drain | | 4 | | |
| F = 1/8" ID Hose Barb | | 6 | | |
| V = Needle Valve | | 10 | | |

For Example: Q1S-AM06-013 for complete assembly, including element. Q1S x 1 for an empty housing.

Miniature T-Model Filter Housings

Features

Stainless steel, Teflon® or Monel construction

Pressure to 345 barg

T-Model construction allows for non-disruptive maintenance

Ideal sample filters for on-line analysers

Models 105S6, 91S6, 95M, 95S6 and 95T

These miniature T-model filters are constructed of 316 stainless steel, Teflon® and Monel. With only 19ml internal volume and the opportunity for by-pass or slipstream filtration using the drain port as an exit port, the model 95 filters are ideal sample filters for on-line analysers. The model 105S6 has a smaller internal volume of 15ml.



MODEL 105S6



MODEL 95S6
& 91S6

Principal Specifications

| Model | 105S6 | 91S6 | 95M | 95S6 | 95T | 95A |
|----------------------------------|-------------------------|-------------------------|-------------------------|-------------------------|--------------------------|-------------------------|
| Inlet and Outlet Ports | 1/8" NPT | 1/8" NPT | 1/8" NPT ⁽¹⁾ | 1/8" NPT ⁽¹⁾ | 1/8" NPT ⁽¹⁾ | 1/8" NPT ⁽¹⁾ |
| Drain Port | 1/8" NPT | 1/8" NPT | 1/8" NPT | 1/8" NPT | 1/8" NPT | 1/8" NPT |
| Materials of Construction | | | | | | |
| Head | 316SS ⁽²⁾ | 316SS ⁽²⁾ | Monel | 316SS ⁽²⁾ | Teflon | Aluminium |
| Bowl | 316SS ⁽²⁾ | 316SS ⁽²⁾ | Monel | 316SS ⁽²⁾ | Teflon | Aluminium |
| Internals | 316SS ⁽²⁾ | 316SS ⁽²⁾ | Teflon | 316SS ⁽²⁾ | Teflon | Aluminium |
| Seals | Viton | Viton | Viton | Viton | Viton | Viton |
| Maximum Temperature | 204°C | 204°C | 204°C | 204°C | 149°C | 93°C |
| Maximum Pressure | 345 barg ⁽³⁾ | 103 barg ⁽³⁾ | 345 barg ⁽³⁾ | 345 barg ⁽³⁾ | 10.3 barg ⁽³⁾ | 172 barg ⁽³⁾ |
| Shipping Weight | 0.4kg | 0.4kg | 0.4kg | 0.4kg | 0.2kg | 0.2kg |
| Dimensions | 40 x 80mm | 40 x 90mm | 40 x 100mm | 40 x 100mm | 40 x 100mm | 40 x 100mm |

Ordering Information

| Filter Housing Model | 105S6 | 91S6 | 95M | 95S6 | 95T | 95A |
|---|----------|----------|------------|------------|------------|------------|
| Support Core, Required for Liquid Filtration | Included | Included | Included | Included | Included | Included |
| Filter Cartridges | 050-07-□ | 050-11-□ | 050-11-□ | 050-11-□ | 050-11-□ | 050-11-□ |
| Use Only These Filter Models | Q,H,S | Q,H,S | Q,H,S, SSC | Q,H,S, SSC | Q,H,S, SSC | Q,H,S, SSC |
| Mounting Bracket | 11038-UK | 11038-UK | 11038-UK | 11038-UK | 11038-UK | 11038-UK |

Notes:

- ¹ Also available with 1/4" NPT ports. To order with 1/4" NPT ports, use designation Model 95S6-1/4
- ² Constructed of materials, which comply with NACE Specification MR-01-75. Request certificate of compliance.
- ³ Maximum pressure ratings are for temperatures to 93°C. Please consult factory for maximum pressure ratings at elevated temperatures.

Teflon®, is a registered trademark of E.I. du Pont de Nemours and Company.
Viton®, is a registered trademark of DuPont Dow Elastomers.



Parker Hannifin (UK) Ltd

Industrial Division, Suite 42, Kent House, Romney Place, Maidstone, Kent ME15 6LH

Tel: +44 (0)1622 772440 Fax +44 (0)1622 772446 E-mail: baststonukinfo@parker.com Web site: www.parker.com

Stainless Steel Inline Filter Housings

Features

All stainless steel construction

Pressure to 345 barg

Temperature to 538°C

Model 97S6, 30/12 and 30/25

The model 97S6 is a miniature 316 stainless steel filter with 1/4" NPT inline ports and 345 barg rating. Since the filter does not have a drain port, the model 97S6 is used as an end-of-the-line compressed gas filter when little or no liquid is expected, for example as a cylinder gas filter.

Models 30/12 and 30/25

Designed specifically for quantitative measurement of solids in gases to 538°C, the filter cartridge and element retainer disc in the model 30 housings may be weighed as a single unit.



MODEL 97S6

Principal Specifications

| Model | 97S6 | 30/12 | 30/25 |
|----------------------------------|-------------------------|-----------------------|-----------------------|
| Inlet and Outlet Ports | 1/4" NPT | 1/2" NPT | 1/2" NPT |
| Drain Port | None | None | None |
| Materials of Construction | | | |
| Head | 316SS | 303SS | 303SS |
| Bowl | 316SS | 304SS | 304SS |
| Internals | 316SS | 303SS | 303SS |
| Seals | Viton | Carbon Fibre | Carbon Fibre |
| Maximum Temperature | 204°C | 538°C | 538°C |
| Maximum Pressure | 345 barg ⁽¹⁾ | 7 barg ⁽²⁾ | 7 barg ⁽²⁾ |
| Shipping Weight | 0.3kg | 0.9kg | 1.4kg |
| Dimensions | 32 x 79mm | 48 x 112mm | 48 x 220mm |

Ordering Information

| Filter Housing Model | 97S6 | 30/12 | 30/25 |
|--|----------|----------|----------|
| Support Core, Required for Liquid Filtration | Included | N/A | N/A |
| Filter Cartridges | 050-05-□ | 100-12-□ | 100-25-□ |
| Important Note: X-model cartridges are not available for the Model 97S6 | | | |

Notes:

¹ Maximum pressure ratings are for temperatures to 93°C. Please consult factory for maximum pressure ratings at elevated temperatures.

² Maximum pressure rating is for temperatures to 538°C.

Viton®, is a registered trademark of DuPont Dow Elastomers.

Low Internal Volume Filter Housings

Features

Stainless steel construction

Pressure to 103 barg

Temperature to 204°C

Compact design



MODEL 47S6



MODEL 91S6

Models 31S6, 31G, 41S6, 91S6 and 41G

These models offer compact designs and half the dead volume of other sample filters, resulting in faster sampling times. They are constructed of stainless steel and available with a variety of seals for easy adaptation to demanding applications.

If larger amounts of condensate are expected, specify 33 or 45 series.



MODEL 31G



MODEL 31S6

Principal Specifications

| Model | 91S6 | 31G | 41G | 31S6 | 41S6 | 47S6 |
|----------------------------------|-------------------------|-------------------------|-------------------------|-------------------------|-------------------------|----------------------|
| Inlet and Outlet Ports | 1/8" NPT ⁽¹⁾ | 1/2" NPT ⁽¹⁾ | 1/2" NPT ⁽¹⁾ | 1/2" NPT ⁽¹⁾ | 1/2" NPT ⁽¹⁾ | 1/4" NPT |
| Drain Port | 1/8" NPT | 1/8" NPT | 1/8" NPT | 1/8" NPT | 1/8" NPT | 1/4" NPT |
| Materials of Construction | | | | | | |
| Head | 316SS ⁽²⁾ | 316SS | 316SS | 316SS | 316SS | 316SS ⁽²⁾ |
| Bowl | 316SS ⁽²⁾ | Pyrex | Pyrex | 316SS | 316SS | 316SS ⁽²⁾ |
| Internals | 316SS ⁽²⁾ | 316SS | 316SS | 316SS | 316SS | 316SS ⁽²⁾ |
| Seals | Viton | Viton | Viton | Viton | Viton | Viton |
| Maximum Temperature | 204°C ⁽³⁾ | 71°C ⁽³⁾ | 71°C ⁽³⁾ | 204°C ⁽³⁾ | 204°C ⁽³⁾ | 204°C ⁽³⁾ |
| Maximum Pressure | 103 barg | 7 barg | 7 barg | 29 barg | 17 barg | 103 barg |
| Shipping Weight | 0.4kg | 0.9kg | 1.8kg | 1.4kg | 2.3kg | 0.4kg |
| Dimensions | 38 x 94mm | 57mm x 140mm | 57 x 260mm | 57 x 146mm | 57 x 260mm | 38 x 94mm |

Ordering Information

| Filter Housing Model | 91S6 | 31G | 41G | 31S6 | 41S6 | 47S6 |
|---|----------|------------|------------|------------|------------|----------|
| Support Core, Required for Liquid Filtration | Included | SS-100-12 | SS-100-25 | SS-100-12 | SS-100-25 | Included |
| Filter Cartridges Use Only These | 050-11-□ | 100-12-□ | 100-25-□ | 100-12-□ | 100-25-□ | 050-11-□ |
| Filter Cartridge Models | Q, H, S | X, H, Q, S | X, H, Q, S | X, H, Q, S | X, H, Q, S | Q, H, S |
| Mounting Bracket | 11038-UK | 11038-UK | 11038-UK | 11038-UK | 11038-UK | Included |

Notes:

- ¹ Also available with 1/4" NPT ports. To order with 1/4" NPT ports, use designation Model 31G-1/4 etc.
- ² Constructed of materials which comply with NACE Specification MR-01-75. Request certificate of compliance.
- ³ Maximum pressure ratings are for temperatures to 104°C. Please consult factory for maximum pressure ratings at elevated temperatures. Viton[®], is a registered trademark of DuPont Dow Elastomers. Pyrex[®], is a registered trademarks of Corning Incorporated.



Parker Hannifin (UK) Ltd

Industrial Division, Suite 42, Kent House, Romney Place, Maidstone, Kent ME15 6LH

Tel: +44 (0)1622 772440 Fax +44 (0)1622 772446 E-mail: baststonukinfo@parker.com Web site: www.parker.com

High Internal Volume Filter Housings

Features

All 316 stainless steel construction

Pressure to 29 barg

Temperature to 204°C

Ideal when a large volume of condensed liquid is expected

Models 33S6, 33G, 45S6, 45G

Higher flow rate filters, all available with 1/4" or 1/2" NPT ports. The 33G and 45G are supplied with a Pyrex glass bowl complete with external plastic shield. These housings are especially useful for gas sampling when a large volume of condensed liquid is expected.



MODEL 33G



MODEL 33S6

Principal Specifications

| Model | 33G | 33S6 | 45G | 45S6 |
|---------------------------------------|---------------------|------------|---------------------|------------|
| Inlet and Outlet Ports ⁽¹⁾ | 1/2" NPT | 1/2" NPT | 1/2" NPT | 1/2" NPT |
| Drain Port | 1/8" NPT | 1/8" NPT | 1/8" NPT | 1/8" NPT |
| Materials of Construction | | | | |
| Head | 316SS | 316SS | 316SS | 316SS |
| Bowl | Pyrex | 316SS | Pyrex | 316SS |
| Internals | 316SS | 316SS | 316SS | 316SS |
| Seals | Viton | Viton | Viton | Viton |
| Maximum Temperature | 71°C ⁽²⁾ | 204°C | 71°C ⁽²⁾ | 204°C |
| Maximum Pressure ⁽²⁾ | 8.6 barg | 29 barg | 8.6 barg | 17 barg |
| Shipping Weight | 1.4kg | 1.4kg | 2.3kg | 2.3kg |
| Dimensions | 70 x 110mm | 70 x 120mm | 70 x 230mm | 70 x 240mm |

Ordering Information

| Model | 33G | 33S6 | 45G | 45S6 |
|---|-----------|-----------|-----------|-----------|
| Support Core, Required for Liquid Filtration ⁽³⁾ | SS-100-12 | SS-100-12 | SS-100-25 | SS-100-25 |
| Filter Cartridges | 100-12-□ | 100-12-□ | 100-25-□ | 100-25-□ |
| Mounting Bracket | 11038-UK | 11038-UK | 11038-UK | 11038-UK |

Notes:

- ¹ Also available with 1/4" NPT ports. To order with 1/4" NPT ports, use designation Model 33G-1/4 etc
- ² Maximum pressure ratings are for temperatures to 93°C. Please consult factory for maximum pressure ratings at elevated temperatures.
- ³ Support core is not required with LP grade cartridges.

Viton® is a registered trademark of DuPont Dow Elastomers.
Pyrex® is a registered trademark of Corning Incorporated.

High Flow Housings for Medium to High Pressure Applications

Features

Stainless steel construction

Pressure to 206 barg

Temperature to 204°C

Ideal for high-pressure applications

Models EU27/35, EU27/80 and 15/80S6

The model EU27/XX and 15/80S6 housings are among the largest 316 stainless steel filters available with high-pressure capability.

The EU27/35 and EU27/80 housings are used when 55 barg rating is required. The EU27/35-3000 and EU27/80-3000 models are suitable for service up to 206 barg. The model 15/80S6 is designed for 2" pipe systems and pressures to 17 barg.



MODEL EU27/35 & EU27/80

MODEL 15/80S6

Principal Specifications

| Model | EU27/35 | EU27/35-3000 | EU27/80 | EU27/80-3000 | 15/80S6 |
|----------------------------------|------------------------|-------------------------|------------------------|-------------------------|------------------------|
| Inlet and Outlet Ports | 1" NPT | 1" NPT | 1" NPT | 1" NPT | 2" NPT |
| Drain Port | 1/4" NPT | 1/4" NPT | 1/4" NPT | 1/4" NPT | 1/4" NPT |
| Materials of Construction | | | | | |
| Head | 316SS ⁽¹⁾ | 316SS ⁽¹⁾ | 316SS ⁽¹⁾ | 316SS ⁽¹⁾ | 316SS ⁽¹⁾ |
| Bowl | 316SS ⁽¹⁾ | 316SS ⁽¹⁾ | 316SS ⁽¹⁾ | 316SS ⁽¹⁾ | 316SS ⁽¹⁾ |
| Internals | 316SS ⁽¹⁾ | 316SS ⁽¹⁾ | 316SS ⁽¹⁾ | 316SS ⁽¹⁾ | 316SS ⁽¹⁾ |
| Seals | Viton | Viton | Viton | Viton | Viton |
| Maximum Temperature | 204°C | 204°C | 204°C | 204°C | 204°C |
| Maximum Pressure | 55 barg ⁽²⁾ | 206 barg ⁽²⁾ | 55 barg ⁽²⁾ | 206 barg ⁽²⁾ | 35 barg ⁽²⁾ |
| Shipping Weight | 7.3kg | 11.4kg | 9.1kg | 11.4kg | 14.5kg |
| Dimensions | 100mm x 410mm | 110mm x 410mm | 100mm x 690mm | 110mm x 690mm | 60mm x 710mm |

Ordering Information

| Model | EU27/35 | EU27/35-3000 | EU27/80 | EU27/80-3000 | 15/80S6 ⁽³⁾ |
|---|-----------|--------------|-----------|--------------|------------------------|
| Support Core, Required for Liquid Filtration | SS-200-35 | SS-200-35 | SS-200-80 | SS-200-80 | SS-200-80 |
| Filter Cartridges | 200-35-□ | 200-35-□ | 200-80-□ | 200-80-□ | 200-80-□ |
| Use Only These | | | | | |
| Filter Cartridge Models | Q, X, H | Q, X, H | Q, X, H | Q, X, H | Q, X, H |
| Mounting Bracket | 11027 | 11027 | 11027 | 11027 | |

Notes:

- 1 Constructed of materials which comply with NACE Specification MR-01-75. Certificate of compliance available on request.
- 2 Maximum pressure ratings are for temperatures to 93°C. Please consult factory for maximum pressure ratings at elevated temperatures.
- 3 Requires element retainer part # 27900
Viton®, is a registered trademark of DuPont Dow Elastomers.



Parker Hannifin (UK) Ltd

Industrial Division, Suite 42, Kent House, Romney Place, Maidstone, Kent ME15 6LH

Tel: +44 (0)1622 772440 Fax +44 (0)1622 772446 E-mail: baststonukinfo@parker.com Web site: www.parker.com

High Pressure Filter Housings

Features

Stainless steel construction

Pressure to 345 barg

Temperature to 204°C

Ideal for removing solids and large quantities of liquid from gases

Model 85

The model 85 filter housing is constructed of 316 stainless steel and has a pressure rating of 345 barg. This model can accommodate X-model filter cartridges and is used when a larger quantity of liquid is expected.

Models EU37/12 and EU37/25

These T-model filter housings are also constructed of 316 stainless steel and have a 276 barg rating. These models are used as sample filters for on-line sample analysers when a larger line size, higher flow rate or larger bowl reservoir capacity is required.



MODEL 85



MODEL EU37/12



MODEL EU37/25

Principal Specifications

| Model | 85 | EU37/12 | EU37/25 |
|----------------------------------|-------------------------|-------------------------|----------------------|
| Inlet and Outlet Ports | 1/4" NPT | 1/2" NPT | 1/2" NPT |
| Drain Port | 1/4" NPT | 1/8" NPT | 1/8" NPT |
| Materials of Construction | | | |
| Head | 316SS ⁽¹⁾ | 316SS ⁽¹⁾ | 316SS ⁽¹⁾ |
| Bowl | 316SS ⁽¹⁾ | 316SS ⁽¹⁾ | 316SS ⁽¹⁾ |
| Internals | 316SS ⁽¹⁾ | 316SS ⁽¹⁾ | 316SS ⁽¹⁾ |
| Seals | Viton | Viton | Viton |
| Maximum Temperature | 204°C | 204°C ⁽²⁾ | 204°C ⁽²⁾ |
| Maximum Pressure | 345 barg ⁽²⁾ | 276 barg ⁽²⁾ | 276 barg |
| Shipping Weight | 1.8kg | 2.7kg | 4.5kg |
| Dimensions | 60 x 130mm | 70 x 150mm | 70 x 250mm |

Ordering Information

| Model | 85 | EU37/12 | EU37/25 |
|---|------------|------------|------------|
| Support Core, Required for Liquid Filtration | Included | SS-100-12 | SS-100-25 |
| Filter Cartridges Use Only These | 050-11-□ | 100-12-□ | 100-25-□ |
| Filter Cartridge Models | X, H, Q, S | X, H, Q, S | X, H, Q, S |
| Mounting Bracket | 11085 | 11038-UK | 11038-UK |

Notes:

- ¹ Constructed of materials which comply with NACE Specification MR-01-75. Certificate of compliance available on request.
- ² Maximum pressure ratings are for temperatures to 93°C. Please consult factory for maximum pressure ratings at elevated temperatures.
Viton[®] is a registered trademark of DuPont Dow Elastomers.

Fast Loop Filters

Features

All 316 Stainless steel construction

Accept Balston disposable microfibre filter cartridges and stainless steel cartridges

Compact design for fast response time

Process stream inlet/outlet ports and sample flow ports are identical, eliminating backup pressure in the system



Model 41GCFL-1/4
Low Pressure



Model 48S6



Model 49S6

Description

Parker fast loop filters are constructed of 316 stainless steel with an optional stainless steel or pyrex bowl. This flow through design continuously flushes the filter cartridge carrying the contaminants back out to the process stream, thus maximizing the filter cartridge life.

Two designs are available. The T-model is suitable for high flow, high volume applications and the inline is ideal for heavily contaminated applications.

Operation

Axial velocity flushes the bulk contaminants through the filter housing back to the process stream. The sample stream passes through the filter cartridge wall with low flow and radial velocity. The clean side of the sample filter system has very low volume which minimizes lag time. This continuous flushing will typically extend filter life by a factor of 4.

Principal Specifications

| Model | 31GCFL-1/4 | 41GCFL-1/4 | 48S6 | 49S6 |
|--|-----------------------|-----------------------|--------------|--------------|
| Inlet and Outlet Ports | 1/4" NPT | 1/4" NPT | 1/4" NPT | 1/2" NPT |
| Drain Port | 1/4" NPT | 1/4" NPT | --- | --- |
| Materials of Construction | | | | |
| Head | 316 SS | 316 SS | 316 SS | 316 SS |
| Bowl ⁽¹⁾ | Pyrex | Pyrex | 316SS | 316SS |
| Internals | 316SS | 316SS | 316 SS | 316 SS |
| Seals | Viton | Viton | Viton | Viton |
| Maximum Temperature | 71°C | 71°C | 204°C | 204°C |
| Maximum Pressure ⁽²⁾ | 7 barg ⁽³⁾ | 7 barg ⁽³⁾ | 345 barg | 103 barg |
| Shipping Weight | 0.9kg | 1.8kg | 0.17kg | 0.39kg |
| Dimensions | 57mm x 140mm | 57mm x 250mm | 32mm x 100mm | 48mm x 178mm |

Ordering Information

| Filter Housing Model | 31GCFL-1/4 | 41GCFL-1/4 | 48S6 | 49S6 |
|---|-------------|-------------|----------|-----------|
| Support Core, Required for Liquid Filtration | SS-100-12 | SS-100-25 | Included | Included |
| Filter Cartridges | 100-12-□ | 100-25-□ | 050-11-□ | 100-185-□ |
| Use only these Filter models | X,H,Q,S,SSC | X,H,Q,S,SSC | X,H,Q | X,H,Q |
| Mounting Bracket | 11038-UK | 11038-UK | | |

Notes:

- 1 Available in all stainless steel construction. Order 31S6CFL-1/4 or 41S6CFL-1/4.
- 2 Maximum pressure ratings are for temperatures to 104°C. Please contact Parker for maximum pressure ratings at elevated temperatures.
- 3 Maximum pressure for stainless steel version is 29 barg.



Parker Hannifin (UK) Ltd

Industrial Division, Suite 42, Kent House, Romney Place, Maidstone, Kent ME15 6LH

Tel: +44 (0)1622 772440 Fax +44 (0)1622 772446 E-mail: baststonukinfo@parker.com Web site: www.parker.com

Petrol Vehicle Emission Analysers

Features

**Complete removal of solid particles,
condensed water and oils**

Long filter life even in high use conditions

**No effect by the filter on the composition of
the sample gas**

Complete analyser protection

Disposable Filter Units (DFU) (see page 16)

These plastic inline disposable filters provide the same high standard of filtration associated with the Balston and Finite brands from Parker.

You can choose fine solids removal, liquid removal by coalescing element and vapour removal by the use of our activated carbon media.

Different grades of filter are available to suit your particular needs for protection and life. The Twist-Lok design (see page 15) is a plastic inline filter with two stage replaceable filters.

Model 58N

The Model 58N housing is a rugged, economical housing. The materials are resistant and non-absorbent to all components of the sample stream. The Grade 404 microfibre filter cartridges were developed specifically for use in sample lines to petrol engine analysers.

Principal Specifications

| Model | Model 58N | Model ETF |
|----------------------------------|---------------|----------------------------|
| Inlet and Outlet Ports | 1/4" NPT | 1/4" NPT |
| Drain Port | 1/8" NPT | 8mm |
| Materials of Construction | | |
| Head | Nylon | Glass filled polypropylene |
| Bowl | Polycarbonate | Polypropylene |
| Internals | Nylon | |
| Seals | Buna | Buna |
| Maximum Temperature | 66°C | 52°C |
| Maximum Pressure | 0.7 barg | 0.7 barg |
| Shipping Weight | 0.5kg | 0.5kg |
| Dimensions | 70mm x 160mm | 70mm x 122mm |

Notes: Filter cartridge not included - must be ordered separately for 58N.

Ordering Information

| Model 58N | Model ETF |
|--|---|
| Replacement Filter Cartridges (box of 10) | Complete Assembly |
| 100-12-404 | ETF-8G |
| | Replacement Bowl complete with cartridge |
| | RBA-8G |
| | Replacement Head |
| | ETF x 1 |



When installed with inside-to-outside flow direction, the filter cartridges are efficient, fast-draining coalescing filters. When installed with outside-to-inside flow direction, the pure white surface of the filter tube permits quick visual estimation of life.

Model ETF

The Model ETF housing is a low-pressure filter designed for vehicle emissions, analyser protection. The all plastic body is in two parts; the head is fixed in the line and the bowl complete with fitted cartridge is self contained and replaceable. Typically a grade 8G element is fitted which can be used as a coalescer to remove liquids or for fine particulate removal. For other grades contact Parker.

Diesel Vehicle Emission Analysers

Features

Long filter life with internal prefilter

Totally inorganic filter cartridge is inert and contains no extractables

Temperature capability to 315°C

Filter housing designed for convenient external heating

The Problem

Diesel exhaust has a high concentration of suspended solid particles and non-volatile liquid droplets. It also has high dewpoint and therefore must be kept hot to prevent liquid condensing and affecting the accuracy of the analysis. To avoid contamination of sample lines with dirt and oil, most diesel engine analysis systems are designed with the primary filter close to the inlet of the sample system. The filter is externally heated to prevent liquid condensation when the system is started up. However, during prolonged operation the filter is subjected to engine exhaust gas temperatures which are normally between 176°C and 232°C and occasionally get as high as 315°C.

The Solution

Model 38 filters, designed specifically for diesel engine exhaust, are all stainless steel housings with silicone seals (maximum temperature 315°C). The 1/4" NPT inlet and outlet ports are located at one end of the cylindrical body and the bayonet closure for changing the filter cartridge is located at the opposite end. To maintain constant temperature, the body may be wrapped in heating tape or enclosed in an oven. The



MODEL 38/12

novel closure design permits an operator wearing gloves to replace a filter element rapidly, without disturbing the heating provisions or gas flow connections.

The filter housing may be oriented horizontally, vertically or at any other convenient attitude. The standard size Model 38/25 housing has a 25cm long body. Where the installation requires a smaller size housing, the Model 38/12 with 14cm long body is available. The Grade DH21 filter cartridge, composed of borosilicate glass microfibrils and inorganic binder, is inert to all components in the gas and stable to 482°C. The retention efficiency is 93% of 0.1 micron particles and 100% of 2 micron and larger particles. With flow direction through the filter tube inside-to-outside, the internal prefilter in the Grade DH21 cartridge provides satisfactory life in a relatively dirty environment. Since the dirt is trapped on the inside of the cartridge, the external surface of the cartridge and the filter housing remain free of contaminants.

Principal Specifications

| Model | 38/12 | 38/25 |
|----------------------------------|-----------------|-----------------|
| Inlet and Outlet Ports | 1/4" NPT | 1/4" NPT |
| Materials of Construction | | |
| Head | Stainless Steel | Stainless Steel |
| Bowl | Stainless Steel | Stainless Steel |
| Internals | Stainless Steel | Stainless Steel |
| Seals | Silicone | Silicone |
| Maximum Temperature | 315°C | 315°C |
| Maximum Pressure | 1.5 barg | 1.5 barg |
| Shipping Weight | 2.3kg | 1.8kg |
| Overall Dimensions | 60mm X 240mm | 60mm X 360mm |

Ordering Information

| Model | | |
|------------------------|-------|--|
| Standard Length | 38/25 | 100-25-DH21 ⁽¹⁾ (box of 10) |
| Short Length | 38/12 | 100-12-DH21 ⁽¹⁾ (box of 10) |

Notes:

Filter cartridge not included. Must be ordered separately

Ordering Information

1. If an H-Model filter element is being used order a modified element retainer kit, P/N 30205.



Parker Hannifin (UK) Ltd

Industrial Division, Suite 42, Kent House, Romney Place, Maidstone, Kent ME15 6LH

Tel: +44 (0)1622 772440 Fax +44 (0)1622 772446 E-mail: baststonukinfo@parker.com Web site: www.parker.com

Alternative Fuel

Features

Complete removal of solid particles, condensed water and oils

Protection of Fuel Injectors and other precision components

Reduced maintenance

Extend equipment life



High Pressure



Low Pressure

Alternative Fuel Filters

Protecting the fuel injectors and precision components of an alternative fuel system is vital to efficient vehicle operation. Parker is now offering the most complete line of fuel filter/coalescers and prefilter/strainers for on-vehicle applications. These filters ensure removal of damaging aerosol contamination as small as 0.3 to 0.6 microns, and exceeding 95% efficiency, depending on the grade of element specified. Units are available in a range of pressure ratings and are constructed of aluminium, stainless steel or painted steel.

The fuel filter/coalescer elements are produced by a patented process of arranging microglass fibres into a tubular form. During operation, fuel is forced through the coalescing media from the inside of the cartridge through the tubular wall to the outside, where the large droplets fall to the bottom of the

housing. Oily water emulsion accumulates until drained while the dirt particles remain trapped on the surface of the fibres. Fuel system engineers and NGV converters agree that a high quality filtration system is an essential alternative engine component. Installed upstream of the high-pressure regulator, the fuel filter/coalescer contributes to maximum uptime, reducing maintenance costs and extending the equipment's life cycle. In addition, some engineers favour the installation of a downstream filter/coalescer to protect the low-pressure regulator and other injection system components.

For pressure equipment (PED) compliance contact Parker for further details

Principal Specifications

| Model | FFC-116 | FFC-112 FFC-112SAE | FFC-110 | FFC-110L | FFC-113 | FFC-114 |
|---|-----------|-----------------------|---|---|----------------|---------------|
| Model | Coalescer | Coalescer | Coalescer | Coalescer | Coalescer | Coalescer |
| Port | 1/4" NPT | 1/4" or 9/16"SAE | 1/4" NPT | 1/4" NPT | 1/2" NPT | 1/2" NPT |
| Barg (Max.) | 345 | 248 | 34 | 34 | 248 | 240 |
| Rated Flow m ³ /h at 7 barg | 14 | 25 | 42 | 84 | 84 | 84 |
| Length mm | 98 | 120 | 182 | 264 | 205 | 178 |
| Diameter mm | 45 | 57 | 80 | 80 | 75 | 75 |
| Drain Port Size | 1/4" | 3/8" SAE | 1/8" | 1/8" | 9/16 SAE -6 | 9/16 SAE-6 |
| Weight Kg | 0.8 | 0.68 | 0.68 | 0.82 | 2.5 | 2.4 |
| Element Number | CLS116-10 | CLS112-10 | CLS110-10 | CLS110-10L | CLS113-6 | CLS113-6 |
| Sump Capacity ml | 7.4 | 14.8 | 148 | 207 | 148 | 89 |
| Material | 316SS | Anodised Aluminium | Powder Painted Chromated Aluminium | Powder Painted Chromated Aluminium | 303SS | 303SS |

Steam Filters - Food Industry

Features

Remove 98+% of 0.01 micron particles and 100% of all visible particles

Remove liquid condensate at the same efficiency as for solid particles

Remove essentially all non-volatile boiler feedwater additives

Stop carryover of boiler feedwater chemicals

Benefits

Balston Steam Filters eliminate particulate contamination of food products caused by direct contact with dirty steam. Other benefits include: reduction in steam condensate mixing with food products when steam is used for agitating, mixing or cooking; elimination of taste and odour problems by reducing boiler feedwater carryover; reduction of maintenance requirements.

Balston Steam Filters

There are numerous steam sterilisation standards, Parker meets all necessary European design regulations and is also in full compliance with the requirements of the US Food, Drug and Cosmetic Act. They also meet the regulations for Indirect Food Additives used as Basic Components for Repeated Use Food Contact Surfaces as specified in 21 CFR Part 177 and Current Good Manufacturing Practices, 21 CFR Part 110. These filters have been accepted by the USDA for use in federally inspected meat and poultry plants. Balston Steam Filters are in full compliance with the 3A Accepted Practices (Number 609-00) for producing steam of culinary quality. They are also in full compliance with the requirements of the Canadian Health Protection Branch.



MODEL SP6-23/75SR

Recommended Steam Filters

For 3/4" and 1" Steam Lines

Model 23/75SR is recommended in smaller lines with a steam flow of up to 227kg per hour. The filter is complete with filter cartridge, steam trap and bleeder valve.

For 1-1/2" Steam Lines

Model SP3-23/75SR is recommended. It will filter up to 680kg of steam per hour. Each of the three filters has its own steam trap. A master trap disposes of most condensate before it reaches the filters. Manifolds can be connected to flow from left to right or right to left.

For 2" Steam Lines

Model SP4-23/75SR is recommended. It will filter up to 907kg of steam per hour. The Model SP6-23/75SR will filter up to 1361kg of steam per hour. Steam trap and manifold features are the same as the Model SP3-3/75.

Principal Specifications

| Model | A23/75SR | SP3-23/75SR | SP4-23/75SR | SP6-23/75SR |
|---------------------------|-------------|-----------------------------------|-----------------------------------|------------------------------------|
| Port Size | 1" BSPT | 1 1/2" NPT | 2" NPT | 2" NPT |
| Maximum Pressure | 8.6 barg | 8.6 barg | 8.6 barg | 8.6 barg |
| Flow Rate | 227kg/hr | 680kg/hr | 907kg/hr | 1361kg/hr |
| Materials of Construction | 304 SS | 304 SS | 304 SS | 304 SS |
| Seals ⁽²⁾ | EPR | EPR | EPR | EPR |
| Shipping Weight | 12kg | 86kg | 100kg | 127kg |
| Dimensions | 180 x 880mm | 740 x 1220 x 530mm ⁽¹⁾ | 910 x 1220 x 530mm ⁽¹⁾ | 1270 x 1220 x 530mm ⁽¹⁾ |

Ordering Information

| Model | A23/75SR | SP3/75SR | SP4-23/75SR | SP6-23/75SR |
|--|-----------|-------------|-------------|-------------|
| Model ⁽²⁾ | 23/75SR | SP3-23/75SR | SP4-23/75SR | SP6-23/75SR |
| Replacement Filter Cartridges (Box of 10) ⁽³⁾ | 200-75-SR | 200-75-SR | 200-75-SR | 200-75-SR |
| Filter Cartridges per housing | 1 | 3 | 4 | 6 |

Notes:

1 Each SP3, SP4, SP6 filter is supplied mounted on a stand. 2 Constructed of food grade EPR. 3 Each Steam Filter Assembly is supplied with filter cartridges installed.



Parker Hannifin (UK) Ltd

Industrial Division, Suite 42, Kent House, Romney Place, Maidstone, Kent ME15 6LH

Tel: +44 (0)1622 772440 Fax +44 (0)1622 772446 E-mail: baststonukinfo@parker.com Web site: www.parker.com

Steam Filters - Sterilisers

Features

Eliminates instrument staining, spotting and rusting caused by wet or dirty steam

Wrapped articles emerge from the steriliser cycle drier and cleaner

Reduced contamination of steriliser interiors. Expensive and time-consuming cleaning is significantly reduced or eliminated

Reduced maintenance of steriliser steam control valves, door seals, and other rubber materials in the steriliser



MODEL A23/75R

How the Balston Steam Filter works

The A23/75R Steam Filter contains a patented Microfibre filter cartridge in a rugged stainless steel housing designed especially for steam service. Included as standard items with the 23R Steam Filter are a stainless steel condensate drain and a high quality bleeder valve. Steam enters the housing and moves into an expansion chamber, where much of the condensate is removed from the steam by the abrupt change in flow direction and velocity. The steam then flows through the Grade R Microfibre filter cartridge. Water draining from the filter cartridges and expansion chamber is removed from the housing by the automatic condensate drain. The Grade R Microfibre filter cartridge combines sturdy construction with remarkably efficient filtration of solid particles and liquid droplets.

The cartridge is rated at 98+% at 0.1 micron. Solid particles remain trapped in the depth of the filter cartridge and water drips from the filter cartridge to the automatic drain. The Microfibre filter cartridge is constructed from chemically inert borosilicate glass fibres and fluorocarbon resin binder. The filter cartridge is completely free of impurities, which could extract into the steam. The Balston A23/75R Steam Filter is recommended for use on 3/4" and 1" steam lines (line sizes for the vast majority of hospital sterilisers). Please consult our technical support department for recommendations on filters for larger steam lines. Use only products designed specifically for steam filtration in steam installations.

Principal Specifications

| Model | A23/75R |
|-------------|--------------------------------------|
| Size | 1" BSPP ⁽¹⁾ |
| Designation | 200-75-R ⁽²⁾ |
| Head | 304SS |
| Bowl | 304SS |
| Internals | 304SS |
| Seals | EPR |
| Pressure | 5.5 barg |
| Weight | 11kg |
| Flow Rate | 160kg/hr (5.5 barg working pressure) |

Ordering Information

| Model | A23/75R |
|---|----------|
| Automatic Drain | Included |
| No. Filter Cartridges Required | 1 |
| Replacement Filter Cartridges (box of 15) | 200-75-R |

Notes:

- The 1" port size can be installed in a 3/4" line by using the appropriate reducing bushings.
- Each filter is supplied with one filter cartridge installed. Replacement filter cartridges are sold in boxes of 15. To order, use complete size and grade designation; for example 200-75-R.

Liquid Filters - Filter Cartridge and Housing Selection

Features

Filtration to 1 micron with exceptional filter life, even for the dirtiest liquids

Excellent chemical and solvent resistance

Compliance with FDA regulations for food contact surfaces

Seven retention efficiency grades cover the range from 75 micron to 0.22 micron

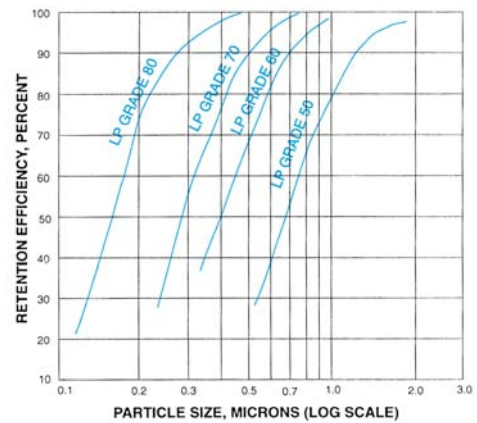

LP Depth Filters

LP Depth Filters

The LP-Grades 10, 20 and 30 depth filter cartridges are constructed entirely of polypropylene and the LP-Grade 50 is constructed of polypropylene, borosilicate glass and polyethylene binder. Both models of cartridges provide excellent chemical and solvent resistance. All LP cartridges have a graded efficiency construction: the filtration efficiency increases from the inside surface to the outside surface, in the direction of flow. This construction provides exceptionally high solids holding

capacity, which translates into a longer life of the filter cartridge. The seven retention efficiency grades offered cover the ranges from 75 micron to 0.22 micron (see table, below).

The Balston LP depth filter cartridges may be used for fine filtration of liquids with heavy dirt loading, when chemical or solvent resistance is required, or as prefilters to ultra-high efficiency or membrane filtration applications.

Retention Efficiency Ratings

LP Depth Filter Cartridges

| Grade | 80% Capture Rating |
|-------|--------------------|
| 10 | 75 micron |
| 20 | 25 micron |
| 30 | 10 micron |
| 50 | 1 micron |

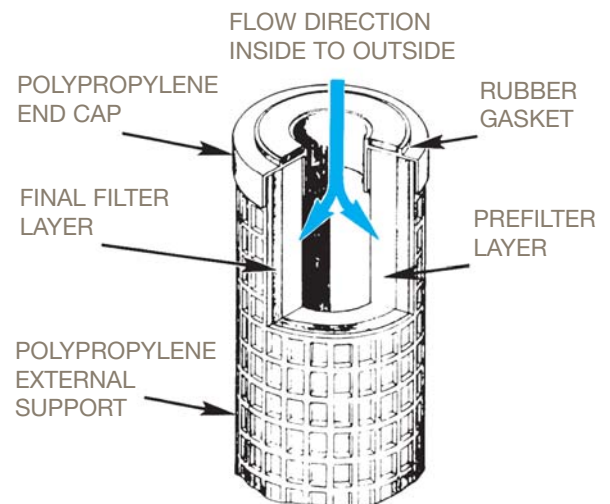

Liquid Filters - Plastic Housings

Model 90

The Model 90 filter holder is designed to accept grade X or Q model filter cartridges. This model is used as the inlet filter on air, gas or liquid sample analysers. It can also be used as a vent/breather filter on storage vessels. The disposable filter cartridge is easily replaced in the field, requiring no tools.

Miniature Model 58P Housing

Has a nylon head, nylon internals and a clear nylon bowl. The Model 58P Housing accepts a single LP cartridge and may be used to filter mildly acidic or caustic solutions.

Model 53 Housings

Are all polypropylene, designed for a single LP-200 filter cartridge. Polypropylene construction provides excellent resistance to non-oxidising acids, such as HCl in any concentration, sulphuric to 70% concentration, brines, hydrocarbon liquids, alcohols and concentrated caustic.

The Model 53 Housings may be used with certain ketones and chlorinated solvents. Please contact Parker for specific recommendations.



Model 58P



Model 53/18, 53/50
and 53/95



Model 54/50

Principal Specifications

| Model | 90 | 58P | 53/18 | 53/50 | 53/95 | 54/50 |
|--|---------------|------------|---------------|---------------|---------------|---------------|
| Inlet and Outlet Ports | 1/4" tubing | 1/4" NPT | 3/8" NPT | 3/4" NPT | 3/4" NPT | 3/4" NPT |
| Materials of Construction | | | | | | |
| Head | Polypropylene | Nylon | Polypropylene | Polypropylene | Polypropylene | Polypropylene |
| Bowl | Polypropylene | Nylon | Polypropylene | Polypropylene | Polypropylene | SAN |
| Internals | - | Nylon | - | - | - | - |
| Seals | - | EPR | EPR | EPR | EPR | EPR |
| Maximum Temperature | 52°C | 66°C | 52°C | 52°C | 52°C | 38°C |
| Maximum Pressure⁽²⁾ | 4.1 barg | 8.6 barg | 8.6 barg | 8.6 barg | 8.6 barg | 8.6 barg |
| Maximum Differential Pressure⁽³⁾ | - | 4 bar | 4 bar | 4 bar | 4 bar | 4 bar |
| Shipping Weight | 0.1kg | 0.5kg | 1.4kg | 1.8kg | 2.7kg | 1.8kg |
| Dimensions | 40 x 100mm | 70 x 160mm | 110 x 170mm | 130 x 300mm | 130 x 560mm | 130 x 300mm |

Ordering Information

| Model | 90 | 58P | 53/18 | 53/50 | 53/95 | 54/50 |
|--|----------|-------------|-------------|-------------|-------------|-------------|
| LP Filter Cartridges, Depth Filters⁽⁴⁾ | 100-12-□ | LP-100-12-□ | LP-200-18-□ | LP-200-50-□ | LP-200-95-□ | LP-200-50-□ |
| Mounting Bracket | - | - | 11039 | 11039 | 11039 | 11039 |
| Number of Cartridges Required | - | 1 | 1 | 1 | 1 | 1 |

Notes:

- 1 Plastic barbs are available to connect the 7700-12 to plastic rubber tubing. 7700-12 to 1/4" ID tubing Part No. 12415 (bag of 2). 7700-12 to 1/2" tubing, Part No. 12416 (bag of 2).
- 2 Maximum pressure ratings are for temperatures to 125°F [52°C]. Please consult the Technical Services Dept. for maximum pressure ratings at elevated temperatures.
- 3 Inside-out flow, LP filter cartridges.
- 4 To order filter cartridges, indicate grade number after size designation. For example, to obtain 0.22 micron depth filter cartridges for the model 53/18, order LP-200-18-80.
- 5 7700-12 is supplied with any grade LP cartridge. To order, put appropriate grade number after 7700-12 designation. For example, to order with LP grade 20 cartridge, order part number 7700-12-20. 7700-12-□ filters are sold one per box.

Liquid Filters - Stainless Steel Housings

Features

316 stainless steel construction

Pressures to 276 barg

Temperature to 82 °C (limited by LP cartridge)

Ideal for high-pressure applications

Models EU37/12 and EU37/25

These T-model filter housings are also constructed of 316 stainless steel, and have a 276 barg rating. These models are used as sample filters for on-line sample analysers when a larger line size, higher flow rate or larger bowl reservoir capacity is required.

Model 27 Housings

Model 27 housings are constructed of 316 stainless steel. These models have 1" NPT ports and are rated to 55 barg. The model 27 housings hold a single LP-200 filter cartridge, available in 10" or 20" length.



MODEL EU37/12



MODEL EU37/25



MODEL EU27/50
& EU27/95

Principal Specifications

| Model ⁽¹⁾ | EU37/12 | EU37/25 | EU27/50 | EU27/95 |
|--|------------|------------|-------------|-------------|
| Inlet and Outlet Ports | 1/2" NPT | 1/2" NPT | 1" NPT | 1" NPT |
| Drain Port | 1/8" NPT | 1/8" NPT | - | - |
| Materials of Construction | | | | |
| Head | 316SS (1) | 316SS (1) | 316SS | 316SS |
| Bowl | 316SS (1) | 316SS (1) | 316SS | 316SS |
| Internals | 316SS (1) | 316SS (1) | | |
| Seals | Viton | Viton | Viton | Viton |
| Maximum Temperature⁽²⁾ | 82 °C | 82 °C | 82 °C | 82 °C |
| Maximum Pressure | 276 barg | 276 barg | 55 barg | 55 barg |
| Maximum Differential Pressure | 4 bar | 4 bar | 4 bar | 4 bar |
| Shipping Weight | 2.7kg | 4.5kg | 7.3kg | 9.0kg |
| Dimensions | 70 x 150mm | 70 x 260mm | 100 x 410mm | 100 x 690mm |

Ordering Information

| Housing ModelModel | EU37/12 | EU37/25 | EU27/50 | EU27/95 |
|---------------------------------------|-------------|-------------|-------------|-------------|
| Filter Cartridge⁽³⁾ | LP-100-12-□ | LP-100-25-□ | LP-200-50-□ | LP-200-95-□ |

Notes:

- Constructed of materials which comply with NACE specification MR-01-75. Request certificate of compliance.
- Limited by maximum temperature of LP filter cartridges.
- To order filter cartridges, indicate grade by putting appropriate grade number after size designation. For example, to obtain 0.22 micron depth filter cartridges for the model 27/50, order LP-200-50-80.



Parker Hannifin (UK) Ltd

Industrial Division, Suite 42, Kent House, Romney Place, Maidstone, Kent ME15 6LH

Tel: +44 (0)1622 772440 Fax +44 (0)1622 772446 E-mail: baststonukinfo@parker.com Web site: www.parker.com

Liquid Filters - Disposable Filter Units for Liquids

Features

Filter samples to on-line liquid analysers

Prevent cross-contamination of samples

Pressure ratings up to 8.6 barg

Temperature to 135°C

Completely disposable, constructed of
recyclable plastics

Disposable Filter Units

Balston Microfibre® Disposable Filter Unit (DFU) consists of a Microfibre Filter Cartridge permanently bonded into a sealed plastic holder with 8.6 barg pressure rating. The economical DFU offers all the advantages of Microfibre Filter Cartridges for high efficiency liquid filtrations, combined with the convenience of complete disposability. The 1/4" O.D. ports permit pressure-tight connections using standard compression fittings. Slip-on 1/4" tubing or plastic barbs may be used for low-pressure applications.

The housings are available in two different materials of construction: clear nylon or corrosion-resistant (opaque) PVDF. The nylon DFU's are designated with the prefix 9933, and the PVDF DFU's are designated with the prefix 9922.

Model 9922-05

The Model 9922-05 DFU's are the smallest DFU's available. They have an internal volume of less than 12ml. The DFU's may be used in low flow liquid applications or sampling systems which require short retention times.

Model 9933-11

The Model 9933-11 DFU's are similar in construction to the Model 9922-05 DFU's, but they have approximately twice the solids holding capacity. The 9933-11 DFU's may be used in higher flow liquid applications or in sampling applications where longer retention times are acceptable.

Retention Efficiency Ratings

| DFU Grade | 98% Retention Particle Size |
|-----------|-----------------------------|
| DQ | 25 micron |
| CQ | 8 micron |
| BQ | 2 micron |
| AQ | 0.9 micron |
| AAQ | 0.3 micron |



9922-XX



9933-XX

| DFU Model | Volume of Housing Litres | Initial Pressure Drop bar | Water Flow Rate, litres per minute | | | | |
|-----------|--------------------------|---------------------------|------------------------------------|----------|----------|----------|-----------|
| | | | Grade DQ | Grade CQ | Grade BQ | Grade AQ | Grade AAQ |
| 9922-05 | 0.1 | 0.07 | 0.76 | 0.63 | 0.19 | 0.09 | 0.03 |
| 4433-05 | 0.1 | - | - | - | - | - | - |
| 9933-05 | 0.1 | 0.34 | 1.90 | 1.58 | 0.95 | 0.46 | 0.12 |
| 9922-11 | 0.02 | 0.07 | 1.14 | 0.95 | 0.34 | 0.16 | 0.04 |
| 9933-11 | 0.02 | 0.34 | 2.84 | 2.33 | 1.64 | 0.76 | 0.20 |

Principal Specifications

| Model | 9922-05 | 9933-05 | 4433-05 | 9922-11 | 9933-11 |
|--|-------------|-------------|--|-------------|-------------|
| Inlet and Outlet Ports | 1/4" Tubing | 1/4" Tubing | 1 st Tier/Barb 1/4" Tubing 2 nd Tier/Barb 3/8" Tubing | 1/4" Tubing | 1/4" Tubing |
| Materials of Construction | PVDF | Nylon | Nylon | PVDF | Nylon |
| Maximum Temperature⁽¹⁾ | 135°C | 110°C | 110°C | 135°C | 110°C |
| Maximum Pressure⁽²⁾ | 8.6 barg | 8.6 barg | 8.6 barg | 8.6 barg | 8.6 barg |
| Dimensions | 25 x 60mm | 25 x 60mm | 25 x 87.2mm | 36 x 120mm | 36 x 120mm |

Ordering Information

| Model | 9922-05 | 9933-05 | 4433-05 | 9922-11 | 9933-11 |
|------------------------|-----------------------|-----------------------|-----------------------|-----------------------|-----------------------|
| Box of 10 DFU's | 9922-05-□ | 9933-05-□ | 4433-05-□ | 9922-11-□ | 9933-05-□ |
| Grades Supplied | DQ, CQ, BQ AQ, AAQ | DQ, CQ, BQ AQ, AAQ | DQ, CQ, BQ AQ, AAQ | DQ, CQ, BQ AQ, AAQ | DQ, CQ, BQ AQ, AAQ |

Notes:

1 At 0 barg.

2 At 43°C

3 Installation Information: Please contact the Technical Services Department for manufacturers of compression and brass fittings.

To Pressure Pipe or Tubing:

Connector 1/4" tubing to 1/4" NPT female P/N 11970 (1 per kg).

Connector 1/4" tubing to 1/4" tubing P/N 11971 (1 per kg).

To Low Pressure Plastic Tubing:

Tubing with 1/4" ID may be slipped over the DFU and fittings and held with tubing clamps. Parker supplies plastic barbs to connect the DFU to smaller diameter tubing. The connection is suitable for pressures up to 3.5 barg.

DFU to 1/16" tubing P/N 1400 (bag of 20 barbs).

DFU to 1/8" tubing P/N 14001 (bag of 20 barbs).

Chemical Compatibility

Models 9922-05, 9922-11

Suitable: Water or steam to 135°C; concentrated nitric, sulfuric and hypochloric acids; chlorine (gas or liquid); sodium hypochlorite, ethylene oxide (gas or liquid); Ferons; ammonia (gas, liquid, or aqueous solutions); hydrogen peroxide (all concentrations); bromine (dry and aqueous solutions); all chlorinated solvents except methylene chloride; all aromatic and aliphatic solvents; all alcohols and glycols; aniline; phenol.

Limited Use: Acetone; MEK; dioxane; furfural; methylene chloride.

Unsuitable: Water above 135°C; THF; DMF; ethylene diamine; chlorosulphonic acid; ethanolamine; pyridine; sulphur trioxide.

Models 9933-05, 9933-11, 4433-05

Suitable: Water to 70°C; benzene, toluene, other aromatic hydrocarbons; hydrocarbon solvents and fuels; perchloroethylene; trichloroethylene; nitric acid (to 10%); sulphuric acid (to 40%); hydrochloric acid (to 10%); most salt solutions; sodium and potassium hydroxide (to 50%).

Limited Use: Water at 80°C; acetone; MEK; acetaldehyde; ammonia (to 25%)

Unsuitable: Water above 70°C; alcohols; glycols; phenol; aniline; DMF; concentrated acids; chlorine.



Parker Hannifin (UK) Ltd

Industrial Division, Suite 42, Kent House, Romney Place, Maidstone, Kent ME15 6LH

Tel: +44 (0)1622 772440 Fax +44 (0)1622 772446 E-mail: baststonukinfo@parker.com Web site: www.parker.com

41

S3.2.143b

Stainless Steel Filters for Food Processing and Packaging

Ideal for all processing and packaging areas that are frequently washed down

Features

All 304 stainless steel construction, ideal standing up to aggressive washroom chemicals

Remove 99.99% of 0.01 micron particles of oil, water and dirt from compressed air and other gases

For sterile air requirements

Remove all viable organisms

USDA accepted for use in federally inspected meat and poultry plants

Low pressure drop

Continuously trap and drain liquids

Remove trace oil vapour with adsorbent cartridges

Benefits

Balston Stainless Steel Filters protect your equipment and delicate instruments from the dirt, water and oil usually found in compressed air and other gases. These filters will remove contaminants at a very high efficiency - up to 99.99% for 0.01 micron particles and droplets. Liquid releases from the filter cartridge to an automatic drain as rapidly as it enters the filter. This allows the filter to continue removing liquids for an unlimited time without loss of efficiency or flow capacity. Select 1/4" to 1" line filters are constructed of 304 stainless steel and are designed to hold up to the harshest environments.

Model 6002

The 6002 series models are 1/4" line size filters designed for lower flow systems and installations with space limitations. It is offered with two drain options, a manual drain or an auto float drain for maintenance free operation.

Model 6004

The 6004 series models are 1/2" line size filters designed for moderate flow rate systems. This series has increased liquid holding capacity which safeguards sensitive end use points from system upsets and morning start-ups.

Model 6006 and 6008

The 6006 and 6008 series models are 3/4" and 1" line size filters respectively. These are designed for high flow rate systems servicing multiple end use points. These are also offered with a high capacity auto float drain option.



Sterile Air Filters

Balston grade SA filter cartridges, rated at 99.9999+% efficiency for 0.01 micron particles, is at least 30 times better than the accepted standard for sterile air filters developed by independent research organisations in the U.S. and U.K. (request bulletin T1-105A for a detailed discussion on Balston filter efficiency rating procedure, and Bulletin T1-935 for an independent test report on Balston Sterile Air Filters). Balston Sterile Air Filters are in full compliance with the requirements of the FDA.

Steam Sterilisation Procedure

In installations where the sterile air filter requires steam sterilisation, we recommend the following procedures:

The steam sterilisation pressure should not exceed 4 barg. Preferably, it should be held to 3 barg or less. A typical sterilisation cycle is 2 barg steam for 30 minutes. Steaming time can be increased as desired without harm to the filter cartridges. The steam flow should not exceed the normal air flow for the unit. To ensure no build-up of condensate in the housing, condensate should be drained from the filter by a condensate drain valve during the steaming process. The cleanliness of the steam is an important factor influencing the life of the Sterile Air Filter cartridges. Parker strongly recommends using Model 23 Steam Filters to ensure optimum operating life (see page 37). When autoclaving, the Grade SA filter cartridges will tolerate temperatures to 149°C in dry gas. Viton® or other heat resistant seals should be used in the housing.

Viton® is a registered trademark of Dupont Dow Elastomers.

Principal Specifications

| Model | 6002N | 6004N | 6006N | 6008N |
|--|---------------------|---------------------|---------------------|---------------------|
| Port Size | 1/4" | 1/2" | 3/4" | 1" |
| Materials of Construction | | | | |
| Head | 304 Stainless Steel | 304 Stainless Steel | 304 Stainless Steel | 304 Stainless Steel |
| Bowl | 304 Stainless Steel | 304 Stainless Steel | 304 Stainless Steel | 304 Stainless Steel |
| Internals | Nylon | Nylon | Stainless Steel | Stainless Steel |
| Seals | Buna-N Food Grade | Buna-N Food Grade | Buna-N Food Grade | Buna-N Food Grade |
| Maximum Temperature⁽¹⁾ | 49°C | 49°C | 49°C | 49°C |
| Maximum Pressure⁽²⁾ | 17 barg | 17 barg | 17 barg | 17 barg |
| Minimum Pressure⁽³⁾ | 1 barg | 1 barg | 1 barg | 1 barg |
| Shipping Weight | 1.6 kg | 1.8 kg | 5 kg | 5.5 kg |
| Dimensions | 70x 180mm | 70 x 250mm | 100 x 250mm | 100 x 300mm |

Notes:





- 1 Max. temperature with auto drain. Max. temperature with manual drain is 135°C.
- 2 Max. pressure with auto drain. Max. pressure with manual drain is 17 barg
- 3 Required for proper operation of auto drain.

Replacement Filter Cartridge Ordering Information

| Model | 6002N | 6004N | 6006N | 6008N |
|--------------------------------------|---------------|---------------|----------------|----------------|
| Replacement Filter Cartridges | | | | |
| Number required | 1 | 1 | 1 | 1 |
| Box of 5 | 5/100-12-[*X] | 5/100-18-[*X] | 5/200-176-[*X] | 5/200-185-[*X] |
| Box of 10 | 100-12-[*X] | 100-18-[*X] | 200-176-[*X] | 200-185-[*X] |
| Box of 10 | 100-12-SA | 100-18-SA | 200-176-SA | 200-185-SA |
| CI Cartridges (box of 1) | CI100-12-000 | CI100-18-000 | CI200-176-000 | CI200-185-000 |

(*replace with B or D)

Ordering Information

| | | | | |
|---|---|---|---|---|
|  |  | |  |  |
| 6002 1/4" Ports | N = NPT Thread Inlet and Outlet Ports | | OA2 Manual Drain | Filter Grade |
| 6004 1/2" Ports | | | OA1 Auto Drain | 000 |
| 6006 3/4" Ports | G = BSPT Thread Inlet and Outlet Ports | | | SA |
| 6008 1" Ports | | | | DX |
| | | | | BX |
| | | | | Leave blank for no filter cartridge |

How to order the Filter Assembly
Build your own custom filter assembly using the guideline matrix (left) and specify your model number.
Example:
1/2" filter and Auto Drain with Grade DX Filter = 6004N-0A1-DX.

Flow Rates m³/hr at 0.14 barg drop at indicated line pressure.

| Filter Housing Model | Port Size | Filter Cartridge Grade | Barg | | | | | | | | | |
|----------------------|-----------|------------------------|------|-----|-----|-----|-----|-----|-----|------|------|--|
| | | | 0.1 | 1.4 | 3 | 6 | 7 | 9 | 10 | 14 | 17 | |
| 6002 | 1/4" | DX | 15 | 32 | 66 | 87 | 107 | 129 | 153 | 199 | 246 | |
| | | BX | 5 | 14 | 19 | 36 | 42 | 53 | 61 | 80 | 99 | |
| | | CI | 3 | 8 | 12 | 20 | 25 | 31 | 37 | 48 | 59 | |
| | | SA | - | 14 | 19 | 36 | 42 | 53 | 61 | - | - | |
| 6004 | 1/2" | DX | 32 | 70 | 110 | 192 | 233 | 282 | 333 | 437 | 537 | |
| | | BX | 15 | 32 | 51 | 87 | 107 | 129 | 153 | 199 | 246 | |
| | | CI | 10 | 20 | 32 | 54 | 66 | 82 | 95 | 124 | 153 | |
| | | SA | - | 32 | 51 | 87 | 107 | 129 | 153 | - | - | |
| 6006 | 3/4" | DX | 63 | 133 | 209 | 364 | 440 | 535 | 630 | 822 | 1013 | |
| | | BX | 17 | 36 | 58 | 95 | 119 | 144 | 172 | 223 | 275 | |
| | | CI | 14 | 27 | 44 | 75 | 90 | 110 | 129 | 168 | 207 | |
| | | SA | - | 36 | 58 | 95 | 119 | 144 | 172 | - | - | |
| 6008 | 1" | DX | 93 | 195 | 308 | 533 | 646 | 787 | 928 | 1208 | 1490 | |
| | | BX | 19 | 39 | 63 | 109 | 131 | 160 | 189 | 245 | 302 | |
| | | CI | 17 | 34 | 54 | 95 | 114 | 139 | 163 | 212 | 262 | |
| | | SA | - | 34 | 70 | 116 | 144 | 177 | 209 | - | - | |

Sterile Gas

Features

- 1/4" to 1" steam sterilisable air filters
- Remove all viable organisms
- Inline steam sterilisation
- Low pressure drop
- Full compliance with FDA requirements
- USDA accepted for use in federally inspected meat and poultry plants

Balston Sterile Air Filters

Balston grade SA filter cartridges, rated at 99.9999+% efficiency for 0.01 micron particles, is at least 30 times better than the accepted standard for sterile air filters developed by independent research organizations in the U.S. and U.K. (request Bulletin TI-105A for a detailed discussion on Balston filter efficiency rating procedure, and Bulletin TI-935 for an independent test report on Balston Sterile Air Filters). Balston Sterile Air Filters are in full compliance with the requirements of the FDA.

Principal Specifications

| Model | A33B | A45B | A27/35B | A27/80B |
|---|------------|------------|-------------|-------------|
| Inlet and Outlet Ports | 1/4" NPT | 1/2" NPT | 1" NPT | 1" NPT |
| Drain Port | 1/8" NPT | 1/8" NPT | 1/4" NPT | 1/4" NPT |
| Materials of Construction | | | | |
| Head | 316SS | 316SS | 316SS | 316SS |
| Bowl | 316SS | 316SS | 316SS | 316SS |
| Internals | 316SS | 316SS | 316SS | 316SS |
| Seals ⁽¹⁾ | Viton | Viton | Viton | Viton |
| Maximum Temperature | 204 °C | 204 °C | 204 °C | 204 °C |
| Maximum Pressure ⁽²⁾ | 29 barg | 17 barg | 55 barg | 55 barg |
| Maximum Steam Pressure for Sterilisation | 4 barg | 4 barg | 4 barg | 4 barg |
| Shipping Weight | 1 kg | 2 kg | 7 kg | 9 kg |
| Dimensions | 70 x 120mm | 70 x 210mm | 100 x 400mm | 100 x 690mm |

Ordering Information

| Model | A33B | A45B | A27/35B | A27/80B |
|--|-------------|-------------|-------------|-------------|
| Assembly with Grade SA Filter Cartridge | A33B-SA | A45B-SA | A27/35B-SA | A27/80B-SA |
| Filter Cartridges: | | | | |
| Number Required | 1 | 1 | 1 | 1 |
| Box of 3 | 3/100-12-SA | 3/100-25-SA | 3/200-35-SA | 3/200-80-SA |
| Box of 10 | 100-12-SA | 100-25-SA | 200-35-SA | 200-80-SA |
| Mounting Bracket | 11038-UK | 11038-UK | 11027 | 11027 |

Notes:

- 1 Constructed of food grade Viton®. Viton® is a registered trademark of DuPont Dow Elastomers.
- 2 Maximum pressure ratings are for temperatures to 54°C. Please contact Parker for maximum pressure ratings at elevated temperatures.



Here's what one of your colleagues found: A Balston sterile air filter assembly, University of Massachusetts, Department of Food Science and Nutrition, under the direction of Professor David A. Evans, Ph.D.

"This sterile air system produced commercially sterile air and, to the limits of detection, no viable colonies of microorganisms were found". - Professor David A. Evans, Ph.D.

Stainless Steel Regulators & Filter Regulators



FR364-02CSS



FB548-02DGCSS



FR10-04CSS



FB11-04DGCSS

Principal Specifications

| Model | FR364-02CSS | FR10-04CSS | FB548-02DGCSS | FB11-04DGCSS |
|-----------------------------------|--|--|--|--|
| Flow | 27 m ³ /h | 135 m ³ /h | 34 m ³ /h | 122 m ³ /h |
| Port Size | 1/4" NPT | 1/2" NPT | 1/4" NPT | 1/2" NPT |
| Gauge Port | 1/4" NPT | 1/4" NPT | 1/4" NPT | 1/4" NPT |
| Drain | - | - | Manual | Manual (automatic optional) |
| Filter Rating | - | - | 5 micron | 5 micron |
| Outlet Pressure Range | 0-8.5 barg | 0-8.5 barg | 0-8.5 barg | 0-8.5 barg |
| Max Inlet Pressure | 20.7 barg | 20 barg | 20.7 barg | 20.7 barg |
| Temperature Range | 4.4-65.6°C | 4.4°C - 65.6°C | 4.4°C -65.6°C | 4.4°C -65.6°C |
| Weight | 0.2 Kg | 0.81 Kg | 0.28 Kg | 1.1 Kg |
| Operation | Fluorocarbon Diaphragm | Fluorocarbon Diaphragm | Fluorocarbon Diaphragm | Fluorocarbon Diaphragm |
| Relieving | Standard (non-relieving optional) | Standard (non-relieving optional) | Standard (non-relieving optional) | Standard (non-relieving optional) |
| Bowl Capacity | - | - | 30 ml | 118 ml |
| Materials of Construction: | | | | |
| Body | 316 Stainless Steel | 316 Stainless Steel | 316 Stainless Steel | 316 Stainless Steel |
| Bowl | - | - | 316 Stainless Steel | 316 Stainless Steel |
| Spring Cage | Celcon | Glass-filled Celcon | Celcon | Glass-filled Celcon |
| Inner Valve | 316 Stainless Steel | 316 Stainless Steel | 316 Stainless Steel | 316 Stainless Steel |
| Bottom Plug | 316 Stainless Steel | 316 Stainless Steel | - | - |
| Seals | Fluorocarbon | Fluorocarbon | Fluorocarbon | Fluorocarbon |
| Adjustment Mechanism | 316 Stainless Steel Spring and 316 Stainless Steel Adjusting Screw | 316 Stainless Steel Spring and 316 Stainless Steel Adjusting Screw | 316 Stainless Steel Spring and 316 Stainless Steel Adjusting Screw | 316 Stainless Steel Spring and 316 Stainless Steel Adjusting Screw |

High Pressure Drain Kits

Product Overview

High pressure compressed gas systems often contain excessive amounts of liquid aerosols. This liquid can best be removed by utilising Parker coalescing filters. A Grade (DX) filter followed by a Grade (BX) filter will remove greater than 99.995% of liquid water and/or oil carryover from the compressed gas system. This liquid can now be safely removed with Parker's NEW High Pressure Drains (JDK). These drains are fully-assembled and are constructed of 316 Stainless Steel. They include two needle valves, fittings, and a pipe reservoir.

The JDK Series is rated for 345 barg and connects to the bottom of the appropriate Parker vessel⁽¹⁾. These High Pressure Drains are offered in both vertical and horizontal orientations. The vertical orientation is ideal for applications in which there is adequate bowl removal clearance, while the horizontal orientation is ideal for applications with limited bowl removal clearance.

Operation

Parker's new High Pressure Drains will allow the user to safely remove condensate from a high pressure compressed gas system. Accurate operation of the drain involves keeping the first needle valve open and the second needle valve closed. The liquid that is coalesced from the filter will empty into the drain's high pressure reservoir and fill the internal volume with liquid.

When it is time to expel the liquid from the drain kit (usually on a preventative maintenance schedule), the top needle valve should be closed to shut off the system pressure. The bottom needle valve should then be opened slowly since the liquid will discharge rapidly from the drain. This procedure should be repeated until all of the liquid has been removed from the filter bowl and drain reservoir.

All liquid should be collected and disposed of in accordance with local regulations.



Principal Specifications

| Model | JDK5000V | JDK5000H |
|----------------------------|--------------------------|----------------------------|
| Description | Vertical ZJ-Series Drain | Horizontal ZJ-Series Drain |
| Inlet | SAE-6 | SAE-6 |
| Outlet | 1/4" NPT | 1/4" NPT |
| Maximum Pressure | 345 barg | 345 barg |
| Maximum Temperature | 38°C | 38°C |

Notes:

¹ Check the size and thread of the drain port on the vessel as an adapter may be required.

Application Notes

Coalescing Filtration: Separating Liquids From Gases

Microfibre Filter Cartridges efficiently separate suspended liquids from gases. The microfibrils capture the fine liquid droplets suspended in the gas and cause the droplets to run together to form large drops within the depth of the filter cartridge. The large drops, forced by the gas, flow to the downstream surface of the filter cartridge, from which the liquid drains by gravity. This process is called "coalescing". Since the coalesced liquid drains from the cartridge at the same rate that liquid droplets enter the cartridge, the cartridge has an unlimited life when coalescing liquids from relatively clean gases, and the filters operate at their initial retention efficiency even when wet with liquid. Note that the flow direction is inside-to-outside, to permit the liquid to drip from the outside of the filter to the housing drain. Since the coalesced liquid drips from the downstream surface of the filter cartridge in the presence of filtered gas, it is important to avoid carryover, or entrainment, of liquid droplets by the gas leaving the filter housing. The possibility of entraining coalesced liquid is minimised by using an DX-Model filter cartridge. The X-Model filter cartridges are constructed of two layers, an inner high-efficiency coalescing layer and an outer layer of coarse glass fibers. The coarse, rapidly-draining outer layer ensures that the liquid drips continuously from the bottom of the filter cartridge and minimises the chance of liquid carryover. (The small internal volume of some filter housings does not permit use of the thick-wall X-Model cartridges, and therefore Q-Model cartridges must be used.) Re-entrainment of coalesced liquid is also avoided by ensuring that the gas flow rate through the housing is safely below the maximum shown in the flow charts on. For most requirements for removing liquid from gas samples, Grade DX or DQ filter cartridges should be used.

Draining Collected Liquid

If liquid is carried into the filter in slugs rather than dispersed as droplets in the gas, a filter which is properly sized for steady-state conditions can be flooded and permit liquid carryover. If slugging of liquid is expected, a filter with a relatively large bowl should be selected to provide adequate liquid holding capacity and provisions should be made to drain the liquid automatically from the bowl of the housing as fast as it accumulates. An automatic float drain can be used if the pressure is in the 0.7-28 barg (10-400 psig) range. Above 28 barg (400 psig), the possibilities are: a constant bleed drain, a valve with automatic timed actuator (supplied by customer), or an external reservoir with manual valves. The external reservoir can be constructed of pipe or tubing with sufficient volume to hold all the liquid which is expected to be collected during any period of unattended operation. If the filter is under vacuum, the external reservoir is a practical method of collecting coalesced liquid for manual draining from time to time. If an external vacuum source, such as an aspirator, is available, the liquid may be drained continuously from the housing drain port.

Coalescing Filtration: Separating Two Liquid Phases

In principle, Microfibre Filter Cartridges separate suspended droplets of a liquid which is immiscible in another liquid by the same process as they separate droplets of liquid from a gas. The liquid droplets suspended in the continuous liquid phase are trapped on the fibres and run together to form large drops, which are then forced through the filter to the downstream surface. The large drops separate from the continuous liquid phase by gravity difference, settling if heavier than the continuous phase and rising if lighter. The coalescing action of Parker filters is effective with aqueous droplets suspended in oil or other hydrocarbons, and also with oil in water suspensions. In practice, liquid-liquid separations are much more difficult than liquid-gas separations. The specific gravity difference between two liquids is always less than between a liquid and a gas, and therefore a longer phase separation time is needed. Either the filter housing must be oversized or the flow rate greatly reduced to avoid carryover of the coalesced phase. As a rule of thumb, flow rate for liquid-liquid separation should be no more than one-fifth the

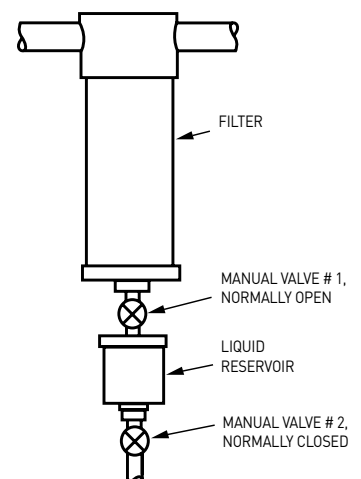

flow rate for solid-liquid separation shown in the chart. Even at low flow rates, if the specific gravity difference between the two liquids is less than 0.1 units (for example, if an oil suspended in water has a specific gravity between 0.9 and 1.1), the separation time for the coalesced phase may be impracticably long. In that case, if there is only a small quantity of suspended liquid, the filter tube can be used until saturated with the suspended liquid and then changed. Another practical problem with liquid-liquid separations is that small quantities of impurities can act as surface-active agents and interfere with the coalescing action. For that reason it is not possible to predict accurately the performance of a liquid-liquid coalescing filter, and each system must be tested on-site. The general guidelines for the system to start testing are to use Grade DX filter cartridges, and flow inside-to-outside at very low flow rates. If the suspended liquid is lighter than the continuous phase, the housing should be oriented so that the drain port is up. In general, Microfibre Filter Cartridges should be used for liquid-liquid coalescing in slipstream sampling applications only.

Membrane Separation of Sample Streams

A Coalescer Membrane Combination Filter is designed to remove entrained liquid and particulate in gas samples for a wide variety of applications, and to prevent contamination or damage to the analysers and sample system components. Microscopic pores contained within the membrane permit molecules of gas or vapour to flow through easily, allowing the composition of the sample gas to remain unchanged. However, even the smallest liquid molecules remain trapped and are unable to flow through the membrane's small passages under normal operating conditions. This is due to the high surface tension which causes liquid molecules to bind tightly together to form a group of molecules, moving together, which is too large to fit through the pores of the membrane. The membrane is extremely inert, and is recommended for most process liquid applications, with the exception of hydrofluoric acid. It is also recommended for use in systems designed for PPB, PPM, and "percent level" component concentrations, as a result of its very low absorption characteristics. The membrane is strong and durable, but also very soft and pliable. Typically located upstream from the analyser or component it is protecting, the Coalescer Membrane Combination provides protection even if other sample system components fail.

Removing Gas Bubbles from Liquids

Microfibre Filter Cartridges readily remove suspended gas bubbles from liquid, eliminating the need for deaeration tanks, baffles, or other separation devices. Flow direction through the filter is outside-to-inside. The separated gas bubbles rise to the top of the housing and are vented through the drain port. If slipstream sampling is used, the separated bubbles are swept out of the housing with the by-passed liquid. Grade DX or Grade DQ is a good choice for gas bubble separation.

Quantitative Measurement of Solids in Gas

Quantitative determination of solids in gas, often a requirement in stack gas or other exhaust gas sampling, is readily accomplished using a Balston Model 30 filter housing. In the Model 30 housing, the filter cartridge is sealed in place by a stainless steel spring acting on a lightweight stainless retainer disc. The retainer disc is pressed firmly into the end of the filter cartridge. When the housing is disassembled, the filter cartridge and retainer disc may be easily removed as a unit. At the beginning of the run, a tare weight is obtained on the filter cartridge-retainer disc assembly. When the filter is in service, flow through the filter cartridge is inside-to-outside so that even large solid particles which fall off the filter cartridge are held in the cartridge-disc assembly. At the conclusion of the run with a known volume of gas, the cartridge-disc assembly is reweighed, and the increase in weight can be expressed as solids concentration in the gas. Grade DH Filter Cartridges are recommended for high temperature sampling up to 482°C (900°F). If the sampling or oven-drying temperatures do not exceed 149°C (300°F), Grade DQ may be used.

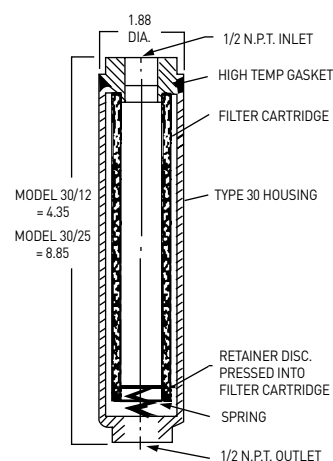

Slipstream or By-pass Sampling

Instrument sample use rates are invariably quite low, yet it is essential to minimise lag time in the sample system. Since analysers often are located some distance from the sampling point, samples are usually transported to the analyser at a relatively high flow rate to minimise lag time. The sample is divided at the analyser, with the analyser using the portion it requires (usually a very small fraction of the total sample), and the balance recycled to the process, or vented. If the sample filter is located in the low flow line to the analyser, it will have good life between filter element changes because the solids loading rate is very low; however, the filter must be carefully selected to avoid introducing unacceptable lag time. If the filter is located in the high flow portion of the sample system, its effect on sample lag time can be relatively low, but the life between filter changes may be inconveniently short because the element is filtering a much greater volume of material than the analyser is using.

Ideally, a filter should be located at the point where the low flow stream is withdrawn to the analyser. This arrangement permits the main volume of the filter to be swept continuously by the high flow rate stream, thus minimising lag time; at the same time, only the low flow stream to the analyser is filtered, thus maximising filter life. A slipstream filter requires inlet and outlet ports at opposite ends of the filter element to allow the high flow rate of the by-passed material to sweep the surface of the filter element and the filter reservoir, and a third port connected to the low flow rate line to the analyser, which allows filtered samples to be withdrawn from the filter reservoir.

The Model 95 housings, 31GCFL, 41GCFL, 48S6, 49S6, DFU 8822-11, and DFU 8833-11 are ideal designs for slipstream sampling, since the inlet and the by-pass ports are located at opposite ends of the housing, and the by-pass port is as large as the inlet port. Larger housings, such as the Model 33S6, Model 45S6, and Model 27/35, can also be used for slipstream sampling, but the relatively small size of the drain port may limit the slipstream rate in some applications. If bubble removal from a liquid is a requirement, this function may be combined with slipstream filtration since the recommended flow direction for bubble removal is outside-to-inside, and the separated bubbles will be swept out of the housing by the by-pass stream. In this case, the liquid feed should enter at the bottom of the housing and the by-pass liquid exit at the top of the housing.

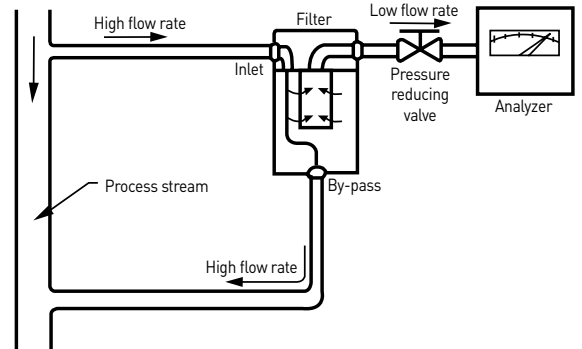

Slipstream Sampling Plus Coalescing Filtration

A special problem arises in slipstream sampling if the filter is to coalesce and continuously drain suspended liquid from a gas stream or to coalesce liquid droplets from a liquid stream. As noted earlier, the coalesced liquid is removed in the form of large drops from the downstream side of the filter. Therefore, the coalescing filter requires two outlet ports, one for the dry gas and one for the liquid drain. To combine coalescing and slipstream filtration, a filter housing would need four ports - two for inlet and by-pass and two for filtered gas and coalesced liquid - which is not a practical design. Therefore, slipstreaming plus coalescing requires two stages of filtration. The second (coalescing) stage must be located in the sample line to the analyser, and should be as small as possible to minimise lag time. If the quantity of suspended liquid is not large, an in-line Disposable Filter Unit (9933-05 or 9922-05) may be considered as a trap for the suspended liquid, to be replaced when saturated.

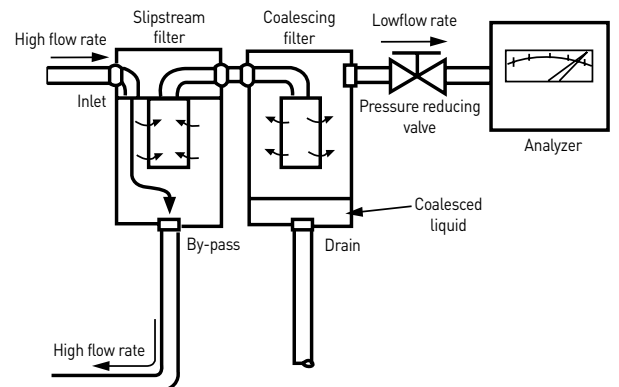

Quantitative Measurement of Liquids in Gas

Quantitative determination of non-volatile liquids suspended in a gas may be accomplished by a procedure similar to the solids determination. In the case of liquids, the test is designed so that all the liquid entering the filter cartridge during the test period remains trapped on the fibres; i.e., the sample period is short enough that the filter cartridge does not become saturated and begin to drain liquid. Any convenient filter housing may be used. The filter cartridge should be Grade BQ, to assure quantitative retention of aerosols, no matter what droplet size. With a known gas flow rate and test duration, the increase in weight of the filter cartridge will be a measure of the weight concentration of aerosol in the gas. Considerable care must be taken to obtain a representative sample of aerosol in gas. If sampling from a large line, the sample probe should enter the pipe from above and if possible, extend into the pipe to avoid picking up liquid clinging to the wall of the pipe. There should be no valves, reducers, or sharp elbows in the sample line upstream from the filter.

Acid Plant Stack Gas

A frequently encountered sampling requirement is to analyse the gas composition in the exhaust from absorbers or scrubbers in acid manufacturing plants. The exhaust gas invariably contains droplets of dilute acid, which must be removed from the sample before it enters the analyser. The recommendations are similar to those for natural gas sample filtration: Grade DQ or DX filter tube, inside-to-outside flow, and two stages of filtration if slipstream sampling is required. Depending upon the composition of the suspended liquid, housings may be stainless steel, Teflon (Model 95T), Monel (Model 95M), or PVDF (DFU 8822-11).

Sampling Ambient Air or Other Atmospheric Pressure Gas

The filtration requirement for ambient air samplers is usually to remove solid particles or liquid droplets which could deposit on analyser optical surfaces or cause other calibration problems. Grade DX or DQ filter cartridges are recommended. For low flow rate personal samplers, the compact and lightweight DFU 9933-05-DQ is often used. For higher flow rates, the Model 90 filter holder with Grade DX or DQ filters is recommended. Ambient air sampling systems are often under negative pressure, induced by the sampling pump. If it is necessary to drain coalesced liquid from the system, the external reservoir is often the most convenient method.

Sampling Water

Most water analysers are well protected against the damage or calibration drift caused by solid contamination if a 10 micron (LP Grade 30) filter cartridge is used. If long filter life is desired in a system with high solids loading (including most tap water, well water, and cooling water), a two stage LP cartridge system is recommended: LP Grade 10 followed by LP Grade 30.

Sampling Liquid Effluent Streams

Liquid effluent analysers usually deal with aqueous streams having a high solids content. In addition, the analysers are often located in remote areas of the plant and are infrequently serviced. Therefore, the sample filter system must have long life between filter cartridge changes, even in a high solids situation. The general recommendation for this requirement is a two stage filter system, LP Grade 10 filter cartridge followed by LP Grade 30 filter cartridge. The filters should be oversized as much as possible without causing excessive lag time. Plastic filter housings are usually a good choice.

Measurements of steam and condensate conductivity, specific ion concentrations, and feedwater additive concentrations are often required in high-pressure boiler systems. In a continuous sampling system, the high pressure steam or condensate is cooled to below 38°C (100°F) and then the pressure is reduced to near atmospheric pressure for metering to the analysers. Filtration is required upstream from the pressure reducing valves, to prevent pitting of the valve seats by suspended particles and to eliminate variations in flow rate to the analysers. A stainless steel filter housing with the appropriate pressure rating and Grade DX or DQ filter cartridge is recommended. Since the analyser system is often located some distance from the sampling point, slipstream filtration is usually required.

On-Line Process Analysers

The variety of filtration requirements for on-line process analysers precludes making general recommendations above for the required filtration functions. The filter housings most frequently used for process analyser applications are the Model 95S6 and Model 91S6, which provide the corrosion resistance of Model 316 stainless steel (complies with NACE specification MR-01-75), a pressure rating of 345 barg (5000 psig), have full slipstream sampling capability, and minimum internal volume.

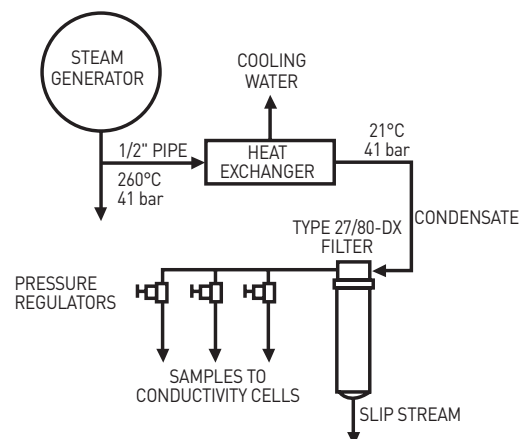

Natural Gas Analysers

To protect gas composition analysers from liquids and solids, Grade DX or DQ filter tubes are recommended, with inside-out flow direction. If both slipstream sampling and coalescing are required, a two stage system must be used, as described on page 48. The Model 85 (345 barg (5000 psig) rating) and Model 37 (276 barg (4000 psig) rating) housings comply with NACE specification MR-01-75. For lower pressure applications, any stainless steel housing of appropriate flow capacity may be used.

Stack Gas Sampling

The Model 30 housing with Grade DH filter cartridge is used for quantitative determination of solids in stack gas, as described on page 34. The Model 30 may also be used as a beginning-of-the-line filter at stack gas temperature (up to 538°C (1,000°F)), to prevent solids from entering the gas sample line. Grade DH is used for this purpose. After the sample is cooled, a coalescing filter with Grade DX tube is used to remove suspended liquids before the sample goes to the analyser. Flow direction is inside-to-outside. Model 33G or 45G housings are often used in this application to permit a visual check on the liquid level in the filter housing. Since there often is a considerable amount of liquid present at this point, positive steps must be taken to drain the housing to ensure that liquid does not build up and carry downstream to the analyser. The coalescing filter should be located as close to the analyser as possible to minimise the chance of condensation between the filter and the analyser. Additional precautions which can be taken to avoid downstream condensation are to cool the sample below ambient temperature upstream from the coalescing filter, and to heat the line.

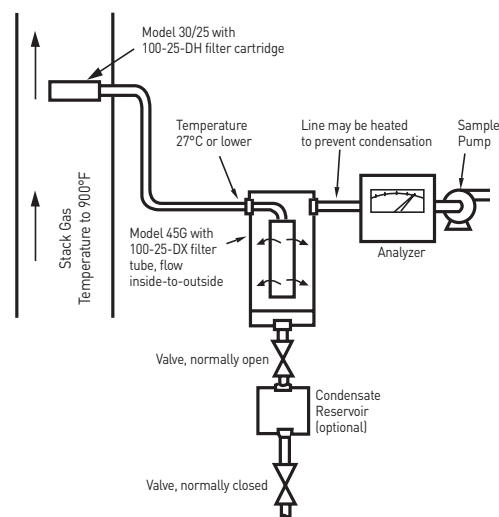

Parker Nitrogen Generation Membrane Technology

Simplicity and elegance describes the working principle of Parker's hollow fibre membrane technology.

Nitrogen is produced from hollow fibres which have selective diffusion rates. As compressed air is passed through the membrane modules consisting of thousands of hollow fibres, nitrogen is separated. Compressed air consists mainly of nitrogen, oxygen and other trace gases such as helium, together with water vapour. Water vapour, helium and oxygen diffuse quickly through the membrane wall, leaving nitrogen as the product.

NitroFlow®

Parker nitrogen generators are based on Parker hollow fibre membrane technology, which makes it possible to separate air into nitrogen and an oxygen-enriched stream.

NitroFlow® is available in both low pressure (LP) and high pressure (HP) ranges. Using NitroFlow® LP when low pressure is needed and opting for NitroFlow® HP when the application requires high pressure or when nitrogen storage is needed.

The NitroFlow® LP range has built-in compressors to produce nitrogen from ambient air simply by connecting to a mains voltage power source. A unique process and system design eliminates the need for condensed water removal and draining, ensuring the longest compressor and membrane life.

The NitroFlow® HP range requires compressed air either from a central system, or from a dedicated compressor. An optional additional storage vessel enables variable or peak consumption to be handled.

NitroFlow® will automatically switch on and off, depending on the nitrogen demand. With low running costs, NitroFlow® offers an unlimited, virtually maintenance-free and reliable source of nitrogen.

TyreSaver®

Specially designed for filling motorcycle, car and truck tyres.

Filling tyres with nitrogen can bring benefits of longer tyre life, better fuel consumption and increased safety.

NitroSource®

A modular design, which accommodates increased requirements through easy expansion.

Digital data management means intuitive commands with advanced features such as data logging and remote control.



Global Company

Local Support

Parker is the leader in motion and control, partnering with its customers to increase their productivity and profitability.

With an annual turnover of over \$10 billion and 57,000 employees Parker measures its success by what it does for you. Guided by a relentless drive to improve your products and processes, we bring our engineering know-how to your application, wherever it may be.

From 60 sales offices in 44 countries around the world Parker services 12,000 distributors and 427,000 customers.



Quality manufacturing

With over 270 manufacturing plants Parker's manufacturing experience spans more than half a century. Our Global reputation as a reliable supplier of superior products results from a focused and integrated development and manufacturing system. This begins with the customer – identifying needs, exploring opportunities and meeting the challenge of change.

Quality permeates through the entire corporation so that every employee thinks about our customers expectations.

Parker makes the technology investments needed to assure the highest quality products. Each of our divisions has ISO certification.

Premier Customer Service

We are doing more for our customers than ever before. Globally, we have localized service to provide fast, hassle free response and on-site support. We're staying close to our customers and integrating systems to help them become more profitable. We are committed to delivering our highly engineered products on-time, on-promise. Parker's global customer service centers respond to more than 20,000 enquiries each month, helping callers quickly find the products and solutions they need.



Innovation

We are leveraging our engineering expertise and breadth of product to create breakthrough innovations, processes and services that anticipate, rather than react, to customer needs. We're adapting our technology platforms across the markets we serve, combining what we know in new ways to better serve our customers. And we're creating smarter products by blending our expertise in electronic controls with our mechanical devices.



Parker Hannifin (UK) Ltd

Industrial Division, Suite 42, Kent House, Romney Place, Maidstone, Kent ME15 6LH

Tel: +44 (0)1622 772440 Fax +44 (0)1622 772446 E-mail: baststonukinfo@parker.com Web site: www.parker.com





Parker Hannifin (UK) Ltd

Industrial Division, Suite 42, Kent House, Romney Place, Maidstone, Kent ME15 6LH
Tel: +44 (0)1622 772440 Fax +44 (0)1622 772446 E-mail: baststonukinfo@parker.com Web site: www.parker.com

Parker Worldwide

AE – UAE, Dubai
Tel: +971 4 8127100
parker.me@parker.com

AR – Argentina, Buenos Aires
Tel: +54 3327 44 4129

AT – Austria, Wiener Neustadt
Tel: +43 (0)2622 23501-0
parker.austria@parker.com

AT – Eastern Europe, Wiener Neustadt
Tel: +43 (0)2622 23501 900
parker.easteurope@parker.com

AU – Australia, Castle Hill
Tel: +61 (0)2-9634 7777

AZ – Azerbaijan, Baku
Tel: +994 50 2233 458
parker.azerbaijan@parker.com

BE/LU – Belgium, Nivelles
Tel: +32 (0)67 280 900
parker.belgium@parker.com

BR – Brazil, Cachoeirinha RS
Tel: +55 51 3470 9144

BY – Belarus, Minsk
Tel: +375 17 209 9399
parker.belarus@parker.com

CA – Canada, Milton, Ontario
Tel: +1 905 693 3000

CH – Switzerland, Etoy
Tel: +41 (0) 21 821 02 30
parker.switzerland@parker.com

CL – Chile, Santiago
Tel: +56 2 623 1216

CN – China, Shanghai
Tel: +86 21 5031 2525

CZ – Czech Republic, Klecany
Tel: +420 284 083 111
parker.czechrepublic@parker.com

DE – Germany, Kaarst
Tel: +49 (0)2131 4016 0
parker.germany@parker.com

DK – Denmark, Ballerup
Tel: +45 43 56 04 00
parker.denmark@parker.com

ES – Spain, Madrid
Tel: +34 902 33 00 01
parker.spain@parker.com

FI – Finland, Vantaa
Tel: +358 (0)20 753 2500
parker.finland@parker.com

FR – France, Contamine s/Arve
Tel: +33 (0)4 50 25 80 25
parker.france@parker.com

GR – Greece, Athens
Tel: +30 210 933 6450
parker.greece@parker.com

HK – Hong Kong
Tel: +852 2428 8008

HU – Hungary, Budapest
Tel: +36 1 220 4155
parker.hungary@parker.com

IE – Ireland, Dublin
Tel: +353 (0)1 466 6370
parker.ireland@parker.com

IN – India, Mumbai
Tel: +91 22 6513 7081-85

IT – Italy, Corsico (MI)
Tel: +39 02 45 19 21
parker.italy@parker.com

JP – Japan, Tokyo
Tel: +(81) 3 6408 3901

KR – South Korea, Seoul
Tel: +82 2 559 0400

KZ – Kazakhstan, Almaty
Tel: +7 7272 505 800
parker.easteurope@parker.com

LV – Latvia, Riga
Tel: +371 6 745 2601
parker.latvia@parker.com

MX – Mexico, Apodaca
Tel: +52 81 8156 6000

MY – Malaysia, Shah Alam
Tel: +60 3 7849 0800

NL – The Netherlands, Oldenzaal
Tel: +31 (0)541 585 000
parker.nl@parker.com

NO – Norway, Ski
Tel: +47 64 91 10 00
parker.norway@parker.com

NZ – New Zealand, Mt Wellington
Tel: +64 9 574 1744

PL – Poland, Warsaw
Tel: +48 (0)22 573 24 00
parker.poland@parker.com

PT – Portugal, Leca da Palmeira
Tel: +351 22 999 7360
parker.portugal@parker.com

RO – Romania, Bucharest
Tel: +40 21 252 1382
parker.romania@parker.com

RU – Russia, Moscow
Tel: +7 495 645-2156
parker.russia@parker.com

SE – Sweden, Spånga
Tel: +46 (0)8 59 79 50 00
parker.sweden@parker.com

SG – Singapore
Tel: +65 6887 6300

SK – Slovakia, Banská Bystrica
Tel: +421 484 162 252
parker.slovakia@parker.com

SL – Slovenia, Novo Mesto
Tel: +386 7 337 6650
parker.slovenia@parker.com

TH – Thailand, Bangkok
Tel: +662 717 8140

TR – Turkey, Istanbul
Tel: +90 216 4997081
parker.turkey@parker.com

TW – Taiwan, Taipei
Tel: +886 2 2298 8987

UA – Ukraine, Kiev
Tel: +380 44 494 2731
parker.ukraine@parker.com

UK – United Kingdom, Warwick
Tel: +44 (0)1926 317 878
parker.uk@parker.com

US – USA, Cleveland
Tel: +1 216 896 3000

VE – Venezuela, Caracas
Tel: +58 212 238 5422

ZA – South Africa, Kempton Park
Tel: +27 (0)11 961 0700
parker.southafrica@parker.com

European Product Information Centre
Free phone: 00 800 27 27 5374
(from AT, BE, CH, CZ, DE, DK, ES, FI, FR, IE, IT, NL, NO, PL, PT, RU, SE, UK, ZA)



Parker Hannifin (UK) Ltd
Filtration and Separation
Industrial Division,
Suite 42, Kent House,
Romney Place, Maidstone,
Kent ME15 6LH
Tel: +44 (0)1622 772440
Fax +44 (0)1622 772446
www.parker.com

January 2008 / S3.2.206b

Your Local Authorized Parker Distributor