

Parker R-max™ Stream Switching System

Catalog 4140-R
Revised, June 2002

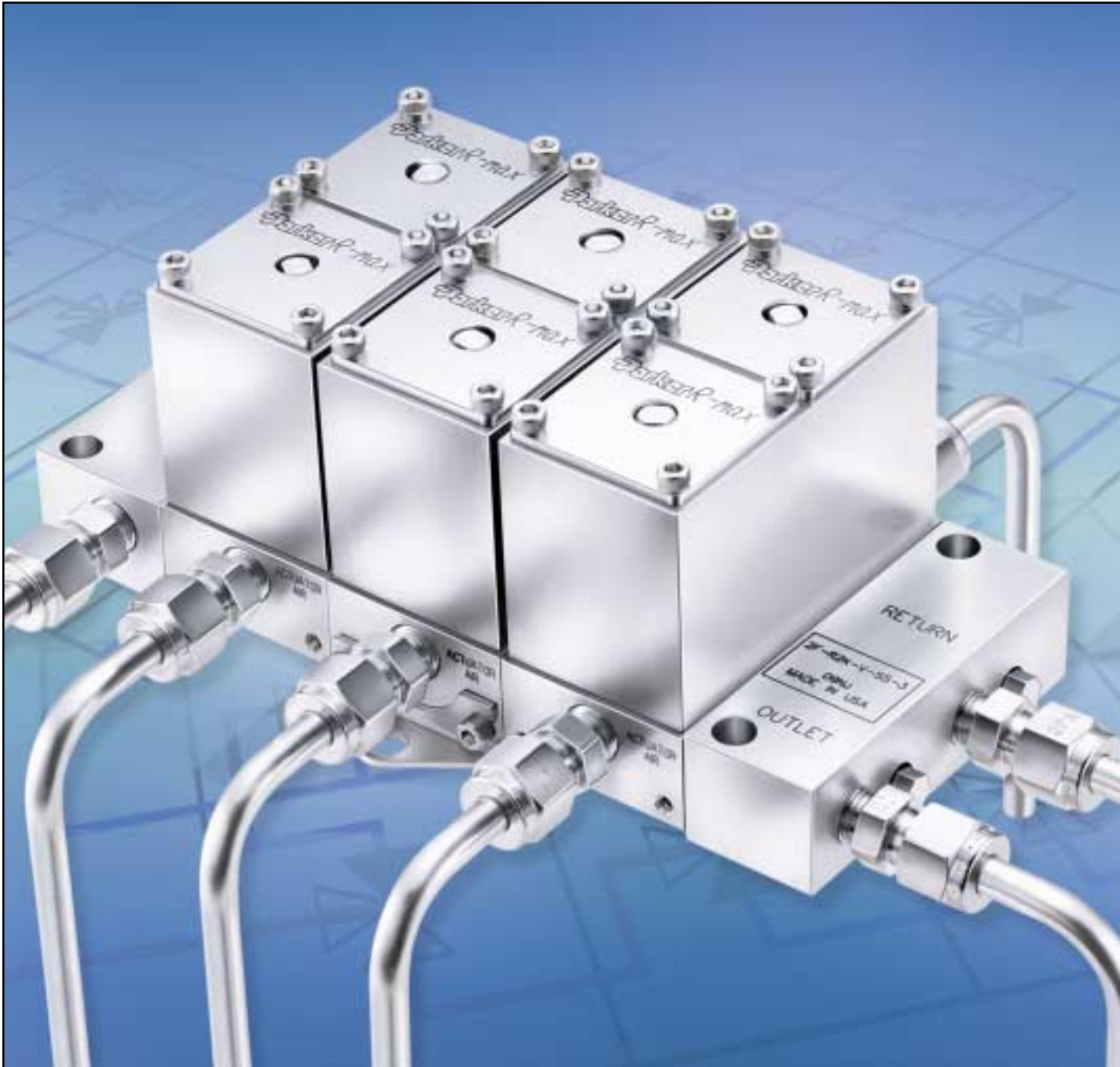

Introduction

The Parker R-max™ is a multi-functional system capable of integrating both stream switching and filtering into one unique compact assembly. The system is designed to control both gases and liquids in analytical systems ranging from vacuum to 500 psig (34 bar) while requiring only 40 psig (3 bar) actuating air pressure. The system was engineered with a focus on improved product reliability and reduced cost of ownership. The Parker R-max™ Stream Switching System utilizes state-of-the-art surface mount technology to reduce leak paths, internal volume, and dead volume. With surface mounting, system components may be easily removed and replaced without breaking process connections. In addition, the Parker R-max™ system utilizes an internal self-purging outlet header to eliminate the need for an additional outlet loop.

Features

- **Surface Mount Technology** enhances **maximum** system flexibility and enables the user to add additional streams to a system without interrupting installed units.
- **PCTFE Sealing Technology** provides **maximum** sealing capability for both gases and liquids to eliminate leakage often found when using elastomeric O-ring seat designs.
- **Low Internal Volume** insures **maximum** system efficiency by reducing purge time and expensive purge gas.
- **Modular Valve Design** offers **maximum** serviceability for quick and easy in-system repair and reduced downtime.
- **Internal Loop Design** eliminates the need for an external loop and provides **maximum** capability with minimum system footprint.
- **Visual Position Indicator** enables the user to easily determine valve position for **maximum** system safety.
- **Low Actuation Pressure** design for maximum sealing capability with **minimum** air supply needs.
- **Patent Pending**

Specifications

- **Pressure Rating:**
500 psig (34 bar) CWP
- **Temperature Ratings:**
 - Fluorocarbon Rubber
-15 °F to 400 °F (-26 °C to 204 °C)
 - Buna-N Rubber
-30 °F to 275 °F (-34 °C to 135 °C)
 - Ethylene Propylene Rubber
-70 °F to 275 °F (-57 °C to 135 °C)
 - Neoprene Rubber
-45 °F to 250 °F (-43 °C to 121 °C)
 - Highly Fluorinated Fluorocarbon Rubber
-25 °F to 200 °F (-32 °C to 93 °C)
- **Flow Data (In a two stream system):**
 - Stream 1: $C_v = 0.128$; $x_T = 0.64$
 - Stream 2: $C_v = 0.099$; $x_T = 0.68$
 - Tested in accordance with ISA S75.02.
 - Gas flow will be choked when $P_1 - P_2 / P_1 = x_T$.

Flow Diagram - Three Stream Switching System

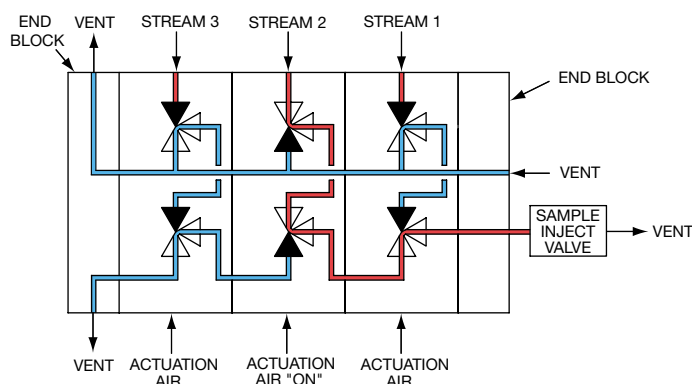

System shown with Stream 2 open to the sample inject valve

Actuation Pressure vs. System Pressure

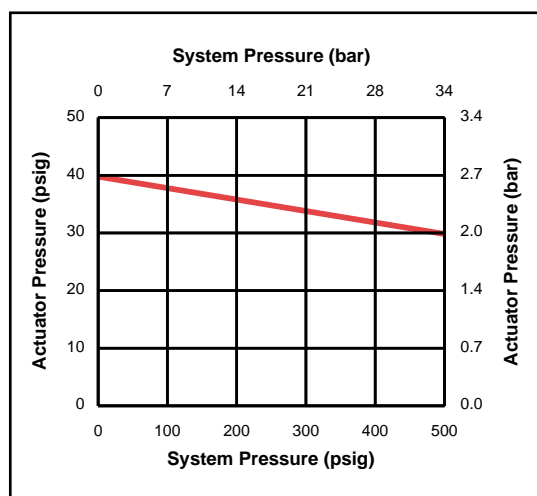

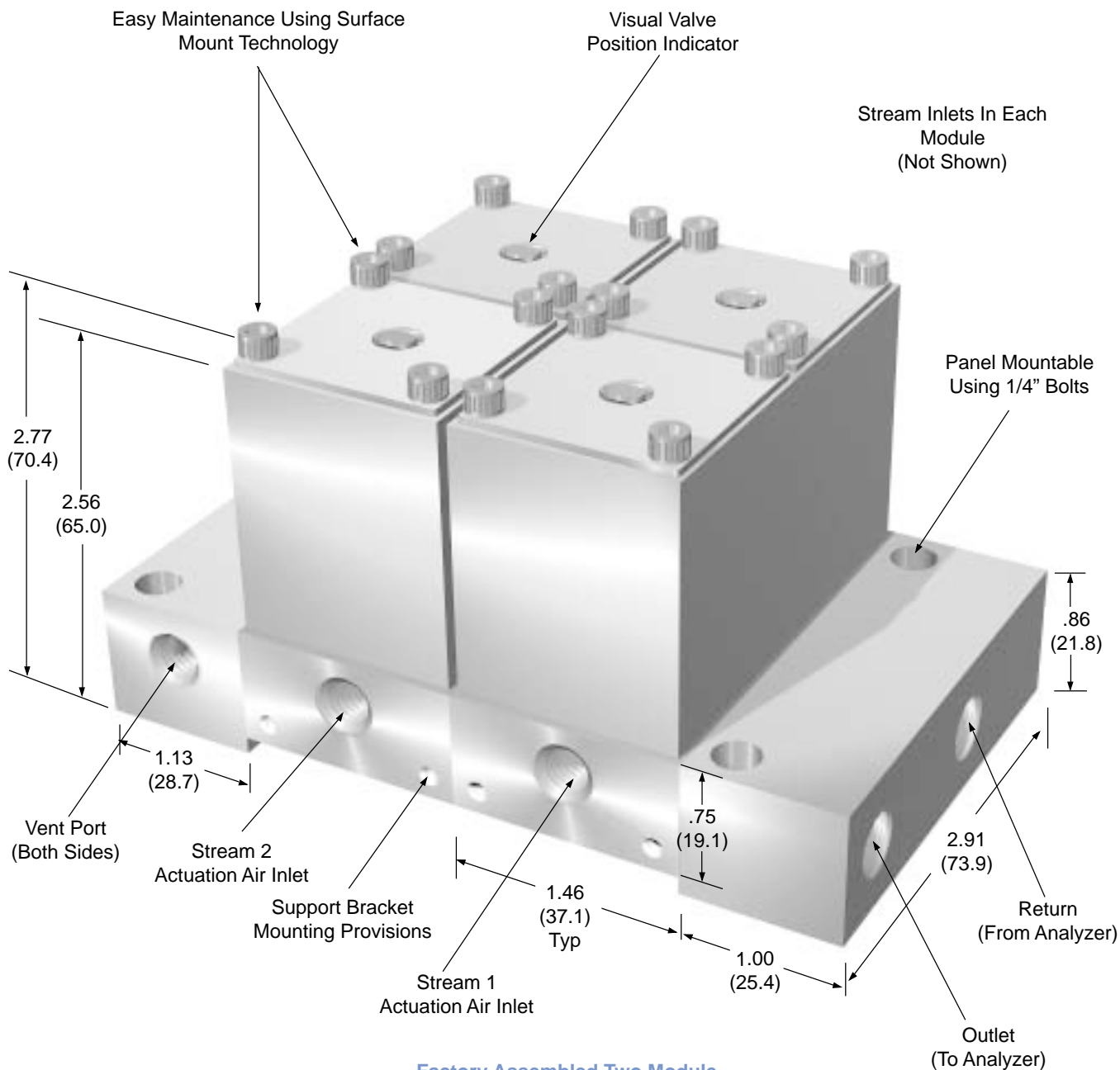

() Denotes dimensions in millimeters

Available End Connections

4A7 - 1/4" Inverted two ferrule A-LOK® compression port



4Z7 - 1/4" Inverted single ferrule CPI™ compression port



2F - 1/8" ANSI/ASME B1.20.1 Internal pipe threads



Note: Actuator air porting and vent porting is always 1/8" FNPT

Valve Module Exploded View

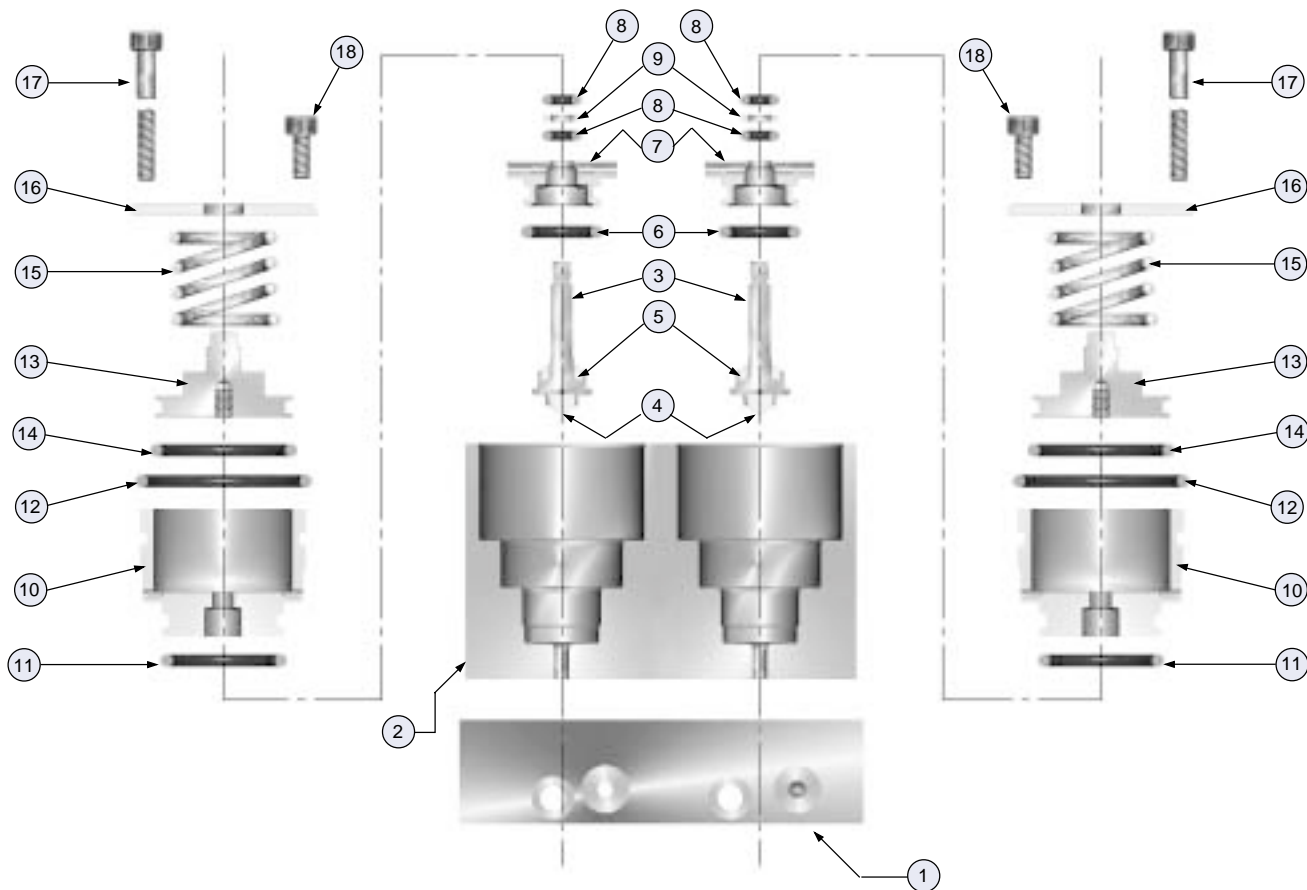

Materials of Construction

Item #	Part Description	Stainless Steel	Alloy N04400
1	Base	ASTM A 479, Type 316	ASTM B 127, Alloy N04400
2	Valve Body	ASTM A 479, Type 316	ASTM B 127, Alloy N04400
3	Stem	ASTM A 479, Type 316	ASTM B 127, Alloy N04400
4	Lower Seat	PTFE	
5	Upper Seat	PTFE	
6	O-Ring 2-013	Optional Elastomers	
7	Lower Bonnet	ASTM A 479, Type 316	ASTM B 164, Alloy N04405
8	O-Ring 2-007	Optional Elastomers	
9	Back-up Ring	PTFE	
10	Upper Bonnet	ASTM A 479, Type 316	ASTM B 164, Alloy N04405
11	O-Ring 2-018	Optional Elastomers	
12	O-Ring 2-023	Optional Elastomers	
13	Piston	ASTM B 211, Alloy 6061	
14	O-Ring 2-020	Optional Elastomers	
15	Spring	ASTM A 564, Type 630	
16	Cap	ASTM A 479, Type 316	
17	Body Bolt	ASTM A 193, Grade B8	
18	Cap Bolt	ASTM A 193, Grade B8	

Note: Material for Stream Switching Vent and Analyzer End Plates (not shown) is ASTM A 479, Type 316 or ASTM B 127, Alloy N04400. Material for Base Plate Bolts is ASTM A 276, Type 316.

Lubrication: Perfluorinated polyether

Valve Module

The Parker R-max™ Stream Switching System centers around the Valve Module, which contains two 3-way valves. Each Valve Module is factory mounted to a Base Plate configured to provide the desired function. The Stream Switching Valve Module provides a double block and bleed arrangement preventing cross contamination of sample streams.

Valve Module Features

- Each Valve Module has a flow inlet and outlet (1/8" FNPT or 1/4" Inverted Compression) and a 1/8" FNPT valve air actuation port.
- Each Valve Module employs two valves.

Valve Module Flow Diagram

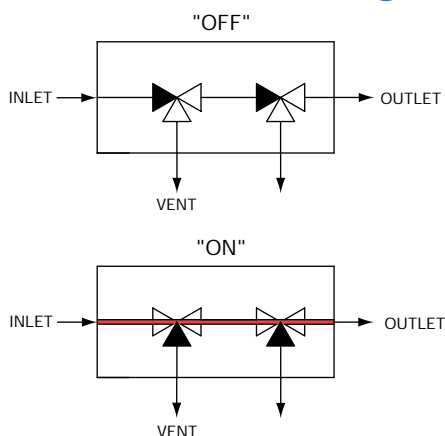

Valve Module Cross Section

Valve Expansion Module - R2EM

Valve Expansion Modules may be added or removed from the Parker R-max™ Stream Switching System. The Valve Expansion Module consists of a Valve Module plus two Base Plate Bolts. They may be inserted between the Vent and Analyzer End Plates to add one or more streams to a system. (See How to Order - Page 9.)

Note: Valve Modules may only be added to an existing stream switching system.



Easy Surface Mount/Module Disassembly

Multi-Stream Switch - R2

A Multi-Stream Switch consists of individual Valve Modules bolted together between Vent and Analyzer End Plates to create an internal, self-purging system with an integral outlet header. This unique design eliminates dead volume and the need for an external loop.

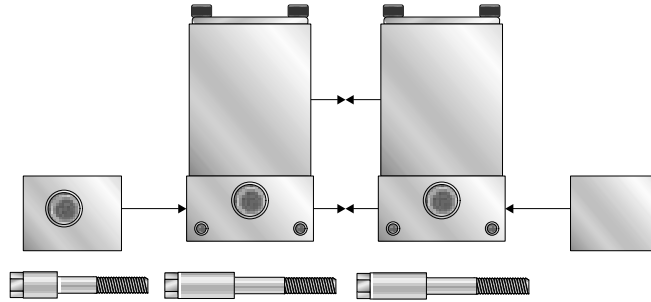

Fast Loop Options

Internal Fast Loop

Example shown is a three stream switching system with an internal fast loop that maintains the double block and bleed feature. Illustrates Streams 1 and 3 in the "Off" position, with these two streams flowing to the common vent. Stream 2 is illustrated in the "On" position, closing the bypass and directing the flow to the analyzer. To order, add the suffix **-IF** to the end of the Stream Switching System part number (See How to Order - Page 9)

Example: 2F-R2K-BN-SS-3-IF

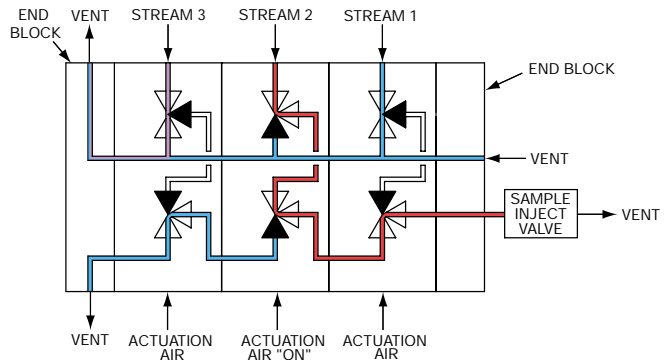

External Fast Loop Kits

Example shown is a three stream switching system with an external fast loop. External Bypass Kits are available to adapt to the standard Parker R-max™ Stream Switching System. The bypass option maintains the double block and bleed feature of the Parker R-max™ System.

Order: KIT-R2-Fitting Part Number-EF

Example: KIT-R2-2MRT2N-316-EF

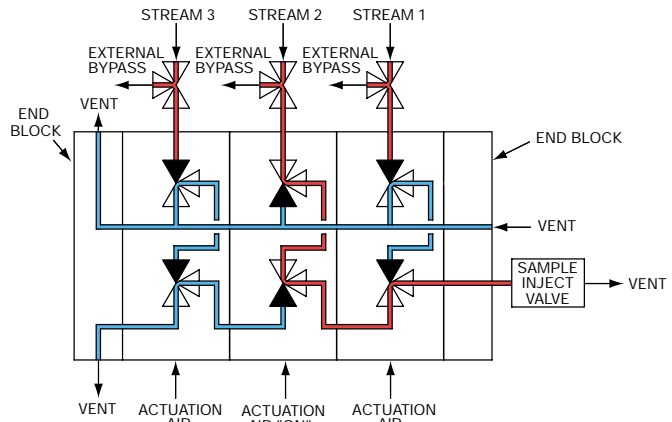

Fast Loop Filters

Example shown is a three stream switching system with two filter bypasses. Bypass Filter Kits may be incorporated into the Parker R-max™ Stream Switching System to enhance your system design.

How to Order: See Page 11

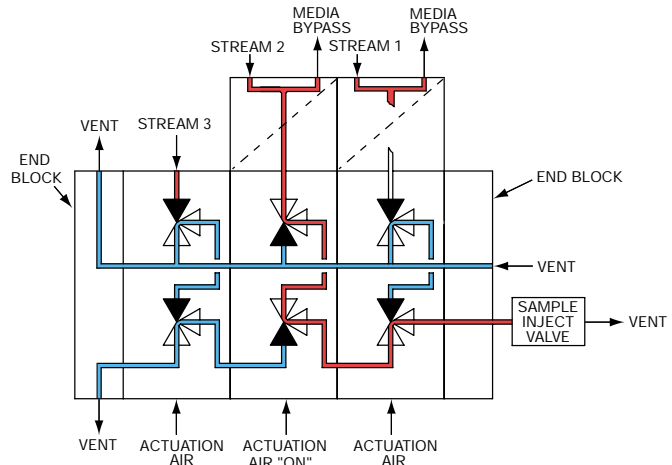

Multi-Stream Switch with GC Module - R2GC

The GC Module is positioned between the analyzer and stream switching system and is used to equilibrate the sample loop pressure to atmospheric pressure just prior to the sample injection. This insures a constant sample pressure in repetitive analyses. When the GC is actuated, the sample from the GC is routed to the low pressure vent.

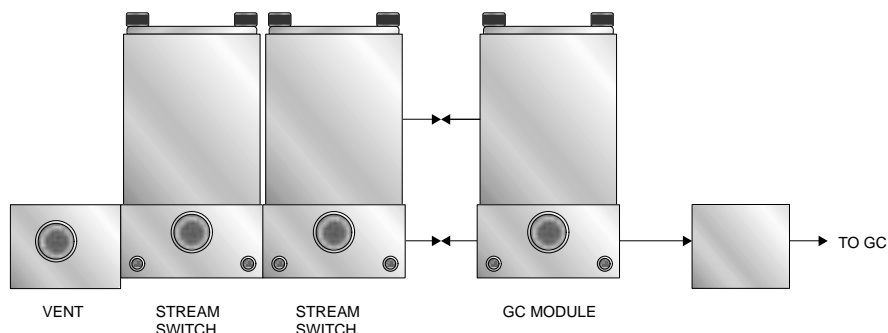

Example Shown: Two streams with GC Module

GC Module Function - Three Stream Examples

Example 1

All valves are in the "Off" position. The system is "Open" to vent.

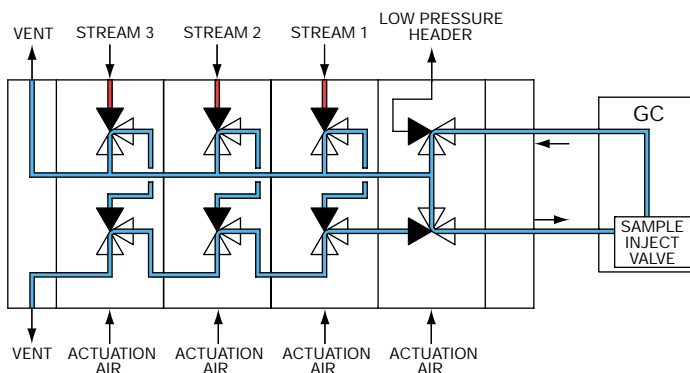

Example 2

Stream 2 and the GC Module are in the "On" position, purging the sample loop to the low pressure header.

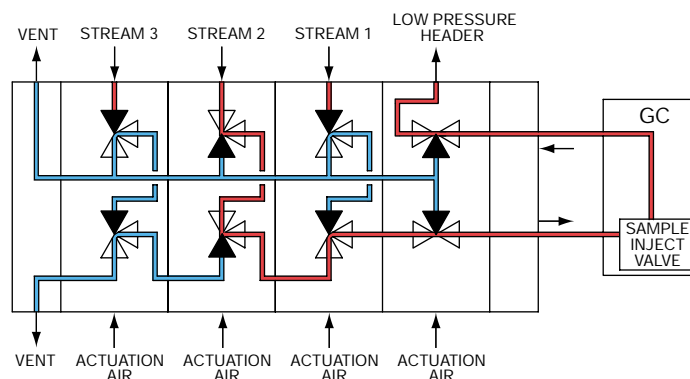

Example 3

Stream 2 is in the "On" position and the GC Module is in the "Off" position, equilibrating the sample loop pressure to vent pressure.

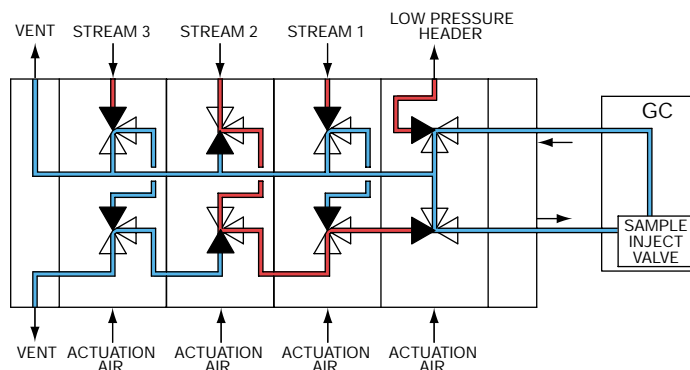

Lab Sample Switch - R2LS

Process stream samples are often collected and analyzed by laboratory personnel to calibrate or verify the accuracy of the process analyzer. The Laboratory Sample Switch is installed in the sample stream on the outlet of the analyzer. The switch is used to route the sample flow to and from a sample container without disturbing or interrupting the analyzer sample flow. Complete Lab Sample Station Kits are also available.

How to Order

Lab Sample Switch

Order: 2F-R2LSK-Seal Material-Body Material

Consists of:

One Parker R-max™ Lab Station Switch

Example: 2F-R2LSK-V-SS

Complete Lab Sample Station Kit

Order: KIT-R2LS-Cylinder Size and Material-Hose Material

Consists of:

Two Connectors;

Two 3-way Ball Valves with PTFE Seats and Seals;

Two Quick Disconnect Couplers with Fluorocarbon Seals;

Two Quick Disconnect Nipples with Fluorocarbon Seals;

One Gauge Port Tee;

One Sample Cylinder Isolation Needle Valve with PTFE Packing;

One Sample Cylinder Isolation Needle Valve with integral Rupture Disc and PTFE Packings and Seals;

One Sample Cylinder (150, 300, or 1000cc) in Aluminum (**A**) or Stainless Steel (**SS**);

One Hose Assembly in Stainless Steel (**SS**) or PTFE (**T**).

Example: KIT-R2LS-150SS-SS

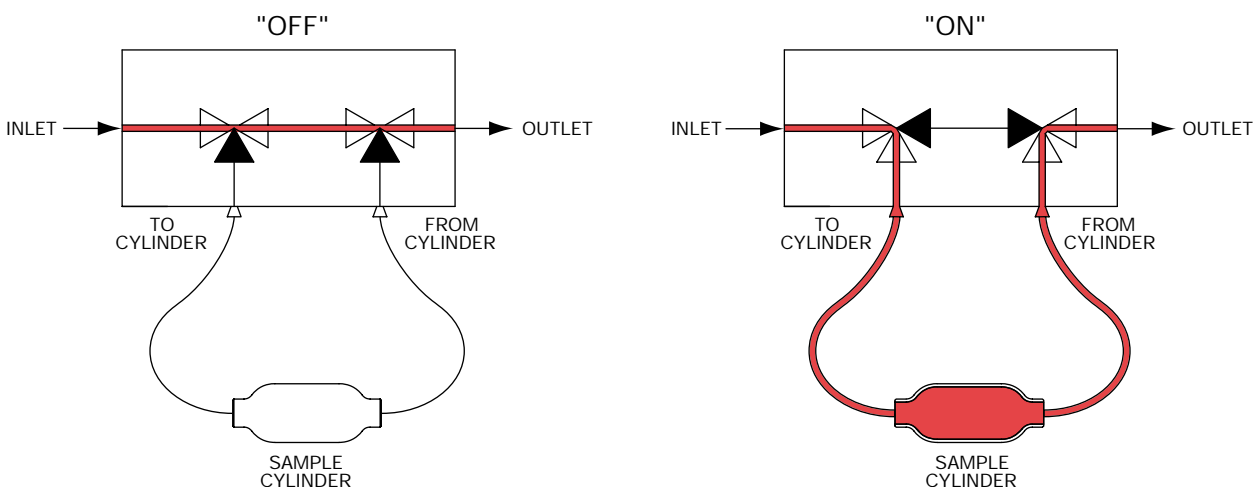
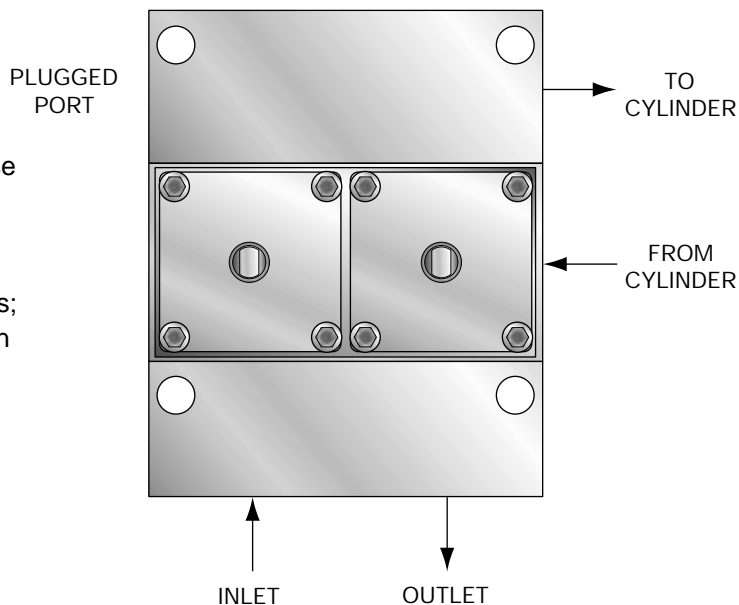

How to Order Stream Switching Systems and Accessories

The correct part number is easily derived by following the circled number sequence. The seven product characteristics required are coded as shown below.

Example 1: $\frac{2F}{\textcircled{1}}$ - $\frac{R2}{\textcircled{2}}$ $\frac{\quad}{\textcircled{3}}$ $\frac{K}{\textcircled{4}}$ - $\frac{V}{\textcircled{5}}$ - $\frac{SS}{\textcircled{6}}$ - $\frac{2}{\textcircled{7}}$

Describes a complete two stream switching system having 1/8" female NPT inlet and outlet ports, PCTFE valve seats, fluorocarbon rubber seals, and stainless steel construction.

Example 2: $\frac{2F}{\textcircled{1}}$ - $\frac{R2}{\textcircled{2}}$ $\frac{GC}{\textcircled{3}}$ $\frac{K}{\textcircled{4}}$ - $\frac{EPR}{\textcircled{5}}$ - $\frac{SS}{\textcircled{6}}$ - $\frac{4}{\textcircled{7}}$

Describes a complete four stream switching system with GC Module having 1/8" female NPT inlet and outlet ports, PCTFE valve seats, ethylene propylene rubber seals, and stainless steel construction.*

End Connection ①	Valve Series ②	Base Option ③	Seat Material ④	Seal Material ⑤	Body Material** ⑥	Number of Modules* ⑦
2F 4A7 4Z7	R2	Blank - None GC - GC Service LS - Lab Switch EM - Valve Expansion Module S - Single Valve	K - PCTFE	V - Fluorocarbon Rubber BN - Buna-N Rubber EPR - Ethylene Propylene Rubber NE - Neoprene Rubber KZ - Highly Fluorinated Fluorocarbon Rubber	SS - Stainless Steel M - Alloy N04400	Numeric Value Blank - LS, EM or S Base Option

*The number of stream modules should not include a GC module in the count if ordered as part of the system.

** Alloy N04400 not available on Single Valve units

How to Order Additional Options

Oxygen Cleaning - Add the suffix **-C3** to the end of the part number to receive stream switching systems or accessories cleaned and assembled for oxygen service in accordance with Parker Specification ES8003.

Example: 4A7-R2K-V-SS-3-C3

How to Order Kits

Stem Seal Kits - KIT-R2K-Seal Material-Body Material. **Example:** **KIT-R2K-V-SS**. (Consists of one stem with PCTFE upper and lower seats, Fluorocarbon O-rings and associated PTFE back-up rings, and maintenance instructions.)

Valve Cartridge Kits - KIT-R2K-CART-Seal Material-Body Material. **Example:** **KIT-R2K-CART-V-SS**. (Consists of one completely assembled valve cartridge and maintenance instructions - Items 3 through 13 from Page 4 Materials of Construction.)

Silcosteel® - Add the suffix **-RTK** to the end of the part number to receive Stream Switching Valves with a thin, permanently bonded silicon based coating which shields sample analytes from adsorption.

WARNING

FAILURE, IMPROPER SELECTION OR IMPROPER USE OF THE PRODUCTS AND/OR SYSTEMS DESCRIBED HEREIN OR RELATED ITEMS CAN CAUSE DEATH, PERSONAL INJURY AND PROPERTY DAMAGE.

This document and other information from Parker Hannifin Corporation, its subsidiaries and authorized distributors provide product and/or system options for further investigation by users having technical expertise. It is important that you analyze all aspects of your application and review the information concerning the product or system in the current product catalog. Due to the variety of operating conditions and applications for these products or systems, the user, through its own analysis and testing, is solely responsible for making the final selection of the products and systems and assuring that all performance, safety and warning requirements of the application are met.

The products described herein, including without limitation, product features, specifications, designs, availability and pricing, are subject to change by Parker Hannifin Corporation and its subsidiaries at any time without notice.

Offer of Sale

The items described in this document are hereby offered for sale by Parker Hannifin Corporation, its subsidiaries or its authorized distributors. This offer and its acceptance are governed by the provisions stated in the "Offer of Sale" located in Catalog 4110-U Needle Valves (U Series).

© Copyright 2002, Parker Hannifin Corporation. All Rights Reserved.

Single Valve

The Parker R-max™ Single Valve shares the same technology, features, and options found in the Stream Switching System. The pneumatically actuated valve serves as a three-way diverting valve with common, normally open, and normally closed porting.

Features

- Surface Mount Technology
- PCTFE Sealing Technology
- Low Internal Volume
- Modular Design
- Visual Position Indicator
- Low Actuation Pressure

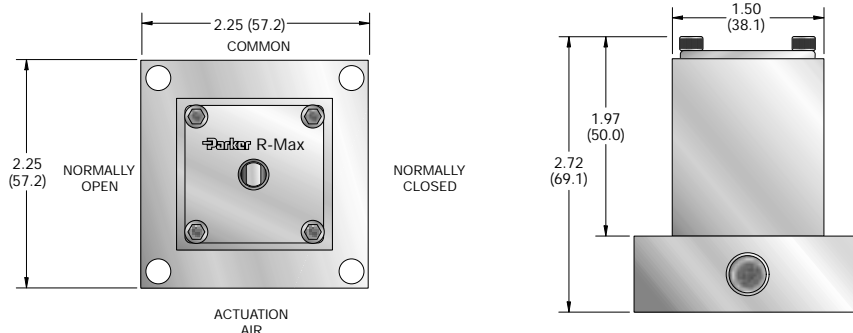

Fast Loop Filters

Designed to be used on the stream inlet ports of the Parker R-max™ Stream Switching System to provide reduced transport time of filtered sample stream media from the process line through the stream switch to the analyzer. This is achieved by diverting approximately 90% of the inlet flow around the cartridge filter and out of the filter bowl.

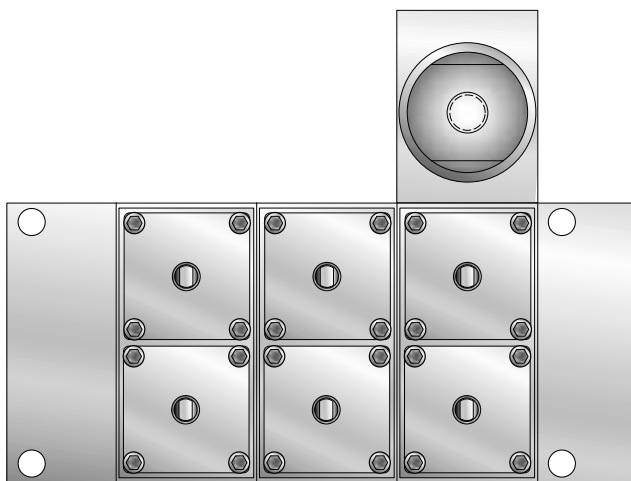
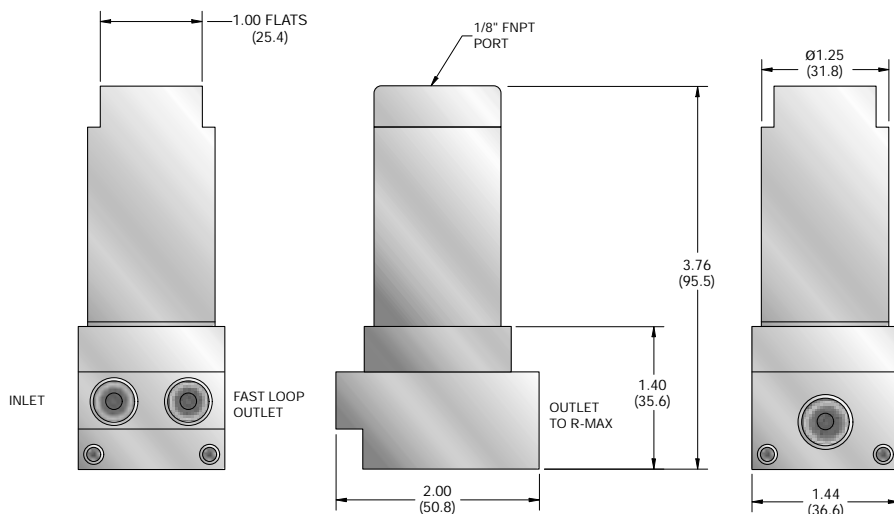

Filter installed on Stream 1 of a Three Stream System

Fast Loop Filter

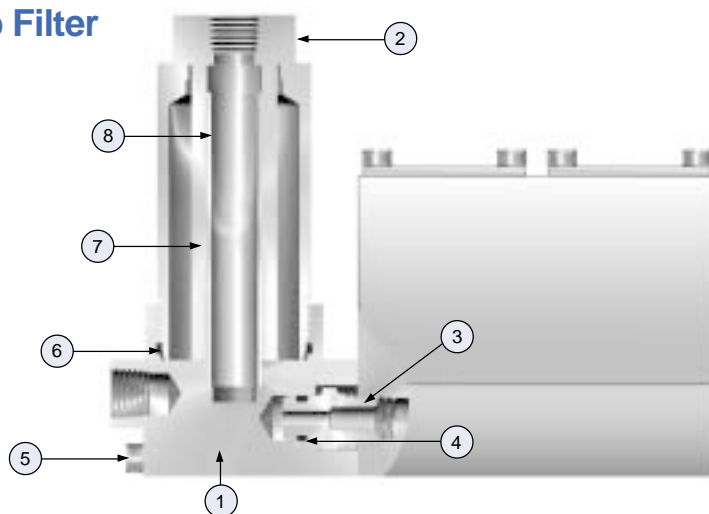

Note: Flow paths in the filter body vary according to the element type and are not shown.

Materials of Construction

Item #	Part Description	Material
1	Body	ASTM A 479, Type 316
2	Bowl	ASTM A 479, Type 316
3	Adapter	ASTM A 479, Type 316
4	O-Ring 2-008	Optional Elastomers
5	Body Bolt	ASTM A 193, Grade B8
6	O-Ring 2-025	Optional Elastomers
7	Element	316SS and Microfibre
8	Support Core	316SS

How to Order Fast Loop Filters

The correct part number is easily derived by following the circled number sequence. The seven product characteristics required are coded as shown below.

Example : 2F - FR2 - EPR - S 100 - SS - B
 (1) (2) (3) (4) (5) (6) (7)

Describes a FR2 Series Fast Loop Filter with 1/8" FNPT inlet and bypass outlets, ethylene propylene rubber seals, 100 micron 316SS sintered metal filter element, stainless steel construction, and designed to be attached to a Parker R-max™ Stream Switch having inverted CPI™ or A-LOK® stream inlet ports.

1 Inlet and Bypass Outlet	2 Filter Series	3 O-Ring Seals	4 Filtration Type	5 Element Type		6 Body Material	7 R-max™ Connection Type
				Balston® P and C	Sintered Meal (S)		
2F - 1/8" Female NPT	FR2	V - Fluorocarbon Rubber	P - Particulate C - Coalescing S - Sintered Metal	93 - 93% Microfibre 99 - 99% Microfibre	100 - 100 micron	SS Stainless Steel	A - 2F B - 4A7 or 4Z7
		BN - Buna-N Rubber			70 - 70 micron		
		EPR - Ethylene Propylene Rubber			40 - 40 micron		
		NE - Neoprene Rubber			20 - 20 micron		
		KZ - Highly Fluorinated Fluorocarbon Rubber			10 - 10 micron 5 - 5 micron		

Fast Loop Filter Options

Silcosteel® - Add the suffix **-RTK** to the end of the part number to receive Filters with a thin, permanently bonded silicon based coating which shields sample analytes from adsorption.

Silcosteel is a registered trademark of Restek Corporation.



Catalog 4140-R, 10M, 06/02

Parker Hannifin Corporation
Instrumentation Valve Division
2651 Alabama Highway 21 North
Jacksonville, AL 36265-9681
USA
Phone: (256) 435-2130
Fax: (256) 435-7718
www.parker.com/IPD



Parker Hannifin plc
Instrumentation Products Division
Riverside Road
Pottington Business Park
Barnstaple, Devon EX31 1NP
England
Phone: +44 (0) 1271 313131
Fax: +44 (0) 1271 373636
Email: ipd@parker.com
www.parker.com/IPD

