

brands you trust.

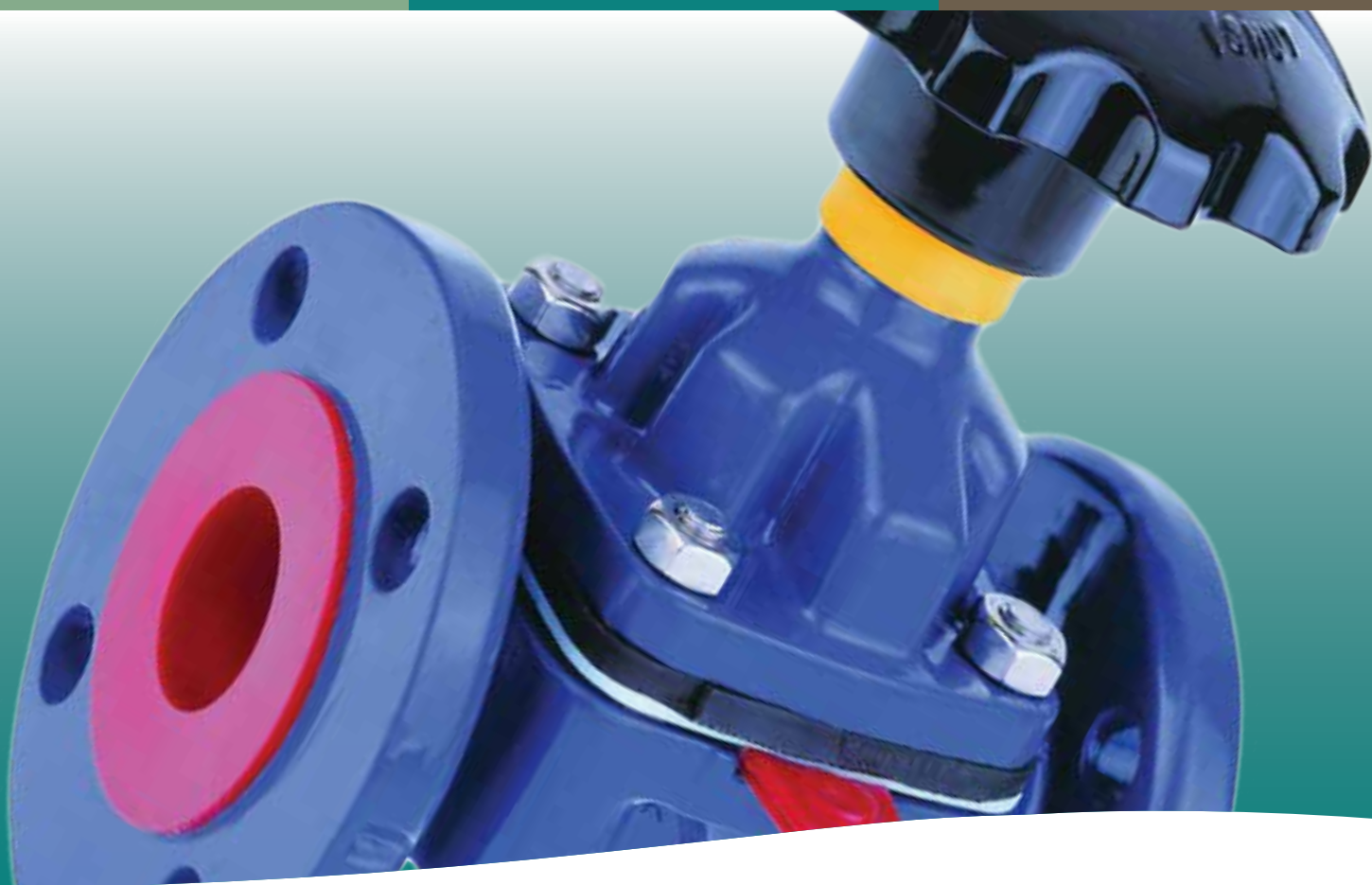

Industrial Diaphragm Valves

OVERVIEW

Pioneers in Diaphragm Valve Technology

Since P.K. Saunders invented the original diaphragm valve in 1928, Saunders® has led the way in providing solutions to industries where flawless operation and resistance to corrosion, abrasion and contamination are imperative. Simplicity of design coupled with more than 85 years of innovation has resulted in the Saunders® diaphragm valve's ability to handle a wider range of fluids than any other valve type. As a result, Saunders® diaphragm valves have gained an excellent reputation for versatility and reliability, establishing a presence in every process industry sector.

Today, Saunders® is an international leader in the design, development and manufacture of diaphragm valves. As part of Crane Co, a diversified global manufacturer of engineered industrial products, Saunders® has a strong worldwide presence via dedicated sales companies and distribution partners.

History of Innovation

Saunders® has led the way in the development of the diaphragm valve to meet the ever-increasing demands of industrial applications:

- PTFE and modified PTFE diaphragms
- Glass and fluorocarbon valve linings
- Non-bonded PTFE diaphragm
- Compact pneumatic actuators
- Three layer diaphragm for corrosive-gas applications
- Diaphragm resistant to both chemical and abrasive attack (XA grade)



Saunders site circa 1939, Cwmbran, UK



Saunders site today, Cwmbran, UK

A Continuing Story of Success

Millions in Service

Saunders® diaphragm valves are used in every process industry. Millions of Saunders® diaphragm valves are currently installed in process plants around the world and they are renowned for versatility and reliability.

Dependable Operation

Engineers know they can trust Saunders® Valves. They set the industry standard for dependable, consistent operation, even in the most adverse conditions with years of trouble-free performance.

Customer Service

Customers know they can depend on Saunders® for after sales service and technical support from one of our many locally-based sales associates and distribution partners.

The Science Inside

Backed by more than 80 years of experience in polymer technology, Saunders® proudly develops and manufactures its own polymer compounds. . It is "The Science Inside™" our valves which sets us apart.

Global Compliance

Saunders® diaphragm valves are fully compliant to all relevant global standards.

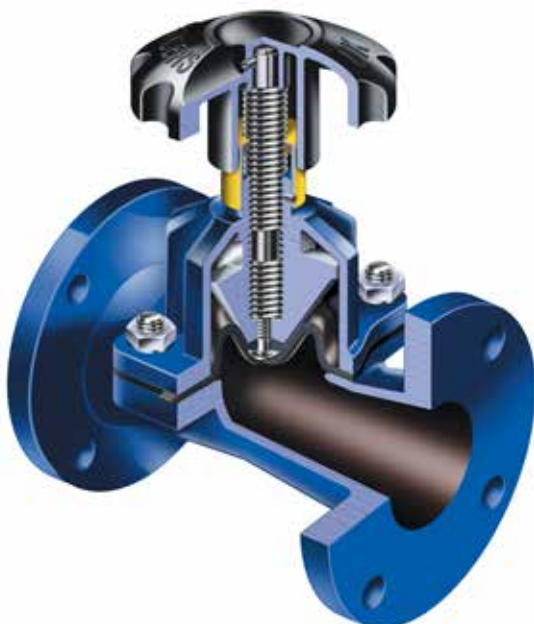

Overview and Introduction

Features & Benefits	4
Key Products	5
Why Diaphragm Valves?	6
Valve Comparison	7
Corrosive Applications	8
Abrasive Applications	9
Other Applications	10
Polymer Science	11
Supporting Data and Certification	12

A Type – Weir Design

Features	13
Standards	14
Body	15
Diaphragm	16
Diaphragm Dimensions	17
Top Works	18
Pressure & Temperature Limits	19
Assembled Valve Dimensions	20
Flow Coefficients	21

KB Type – Straight Through Design

Features	23
Standards	24
Body	25
Diaphragm	26
Diaphragm Dimensions	27
Top Works	28
Pressure & Temperature Limits	29
Assembled Valve Dimensions	30
Flow Coefficients	31

WFB Type Design

Features	33
Standards	34
Body & Diaphragm	35
Fully Assembled Valve	36
Special Versions	37

NX – Check Valves

Features	38
Assembled Valve Dimensions	39
Disc Type & Flow Coefficients	40

Actuation

ES Modular Design	41
Model Range & Modes of Operation	42
Sizing Your Actuator	43
ESM/ES Actuators	44
EC Actuators	47
ECX Actuators	49
Actuation Accessories	51

Catalogue Codes

Storage, Installation, Operation & Maintenance	56
--	----

FEATURES & BENEFITS

Superior Sealing for Chemical and Abrasive Processing Applications.

- 1 **The Science Inside®:** Proprietary diaphragm technology provides exceptional sealing and complete emissions control.
- 2 **Unmatched Expertise & Innovation:** A comprehensive selection of polymers delivers superior corrosion and abrasion resistance for a wide range of demanding applications, since 1928.
- 3 **Efficient Operation:** Top-entry design enables in-line maintenance to reduce plant downtime.



KEY PRODUCTS

A Type Weir Design for Corrosive Media and Utilities

- Versatile and extensively used in industrial applications
- Can handle up to 15% solids (depending on process conditions)
- Perfect valve for on/off or control applications on corrosive processes

KB Straight Through Designs for Solids Handling

- Smooth, straight-through design
- High flow capacity
- Can handle highly abrasive fluids

WFB For Marine and Fire Applications

- Weir type valve for fire fighting, tank cleaning or wash down on land or sea
- Guaranteed operation even after years of being static
- Fire tested diaphragm

NX Check Valve

- Low pressure and vacuum duties
- Unidirectional full flow design
- Corrosion resistant linings

Actuation - Modular or Compact Actuators

- Different actuator types that cover up to DN250
- Wide range of line and operating pressure options
- Conceived to withstand the most adverse conditions

In-house Manufacture of All Diaphragms

- Vulcanized layers with high strength woven reinforcement in elastomer-based diaphragms
- Range of PTFE-type diaphragms for critical applications
- Innovative compounding based on extensive polymer knowledge

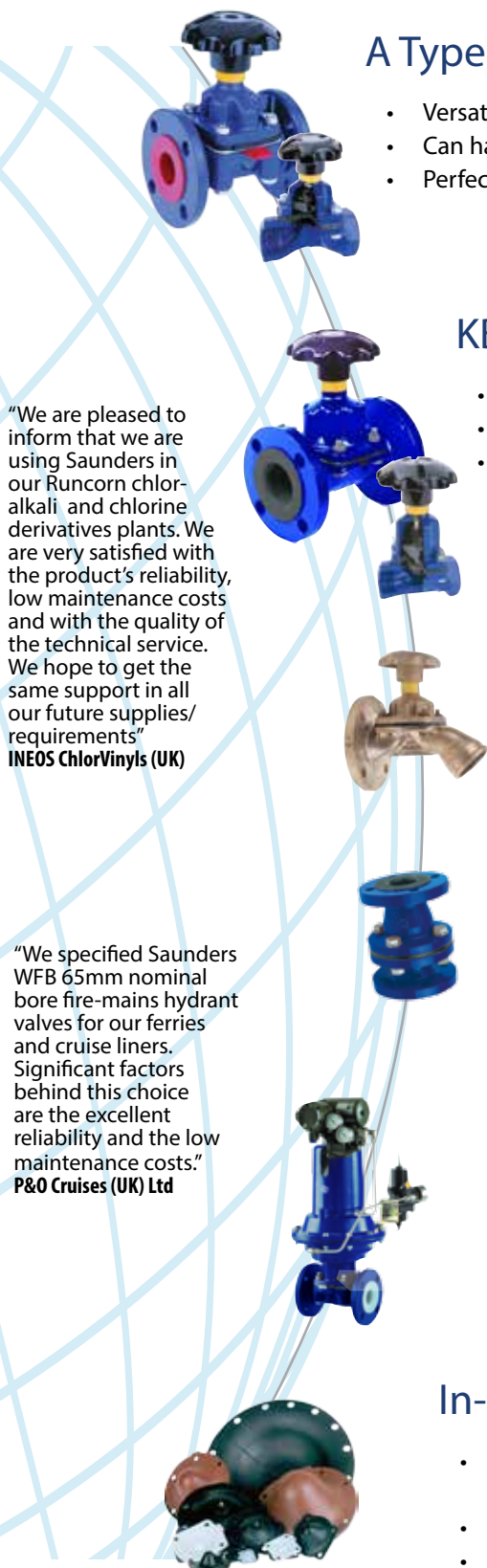

"We are pleased to inform that we are using Saunders in our Runcorn chlor-alkali and chlorine derivatives plants. We are very satisfied with the product's reliability, low maintenance costs and with the quality of the technical service. We hope to get the same support in all our future supplies/requirements"
INEOS ChlorVinyls (UK)

"We specified Saunders WFB 65mm nominal bore fire-mains hydrant valves for our ferries and cruise liners. Significant factors behind this choice are the excellent reliability and the low maintenance costs."
P&O Cruises (UK) Ltd

WHY DIAPHRAGM VALVES?

1 Corrosion Resistance

Saunders lined valves are the first choice for highly-corrosive applications. We offer an extensive range of linings and diaphragms to suit most applications. This wide selection of body lining and diaphragm materials provides an effective and economical solution by eliminating the need for exotic alloys. Our extensive range of valve options include elastomer and fluoropolymer linings, designed especially to combat corrosion.

3 Leak Tight

In pressure and vacuum services, Saunders diaphragm valves deliver 100% leak-tight shutoff in accordance with standards MSS SP-88 and BS EN 12266-1, even after thousands of operations. This reduces processing and handling costs by eliminating emissions commonly associated with other valve designs.

5 Easy Maintenance

A three-part design allows maintenance and actuator retrofitting without removing the valve body from the pipeline. Overall, this results in lower cost of ownership compared to other valve types.



7 Linear Operation

Linear movement of the valve eliminates the rotational seat wear that is characteristic of quarter-turn valves, resulting in a longer service life and reduced total cost of ownership. This results in a longer service lifetime.

2 Abrasion Resistance

Saunders polymer technology provides superior abrasion resistance. The KB straight through valve will handle up to 100% solids and ensure leak-free shut off with a soft rubber diaphragm.

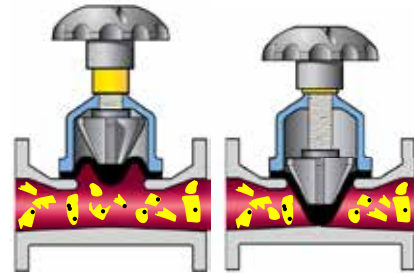

4 Operating Mechanism Isolated from Line Media

All working parts of the valves are isolated from the line media and positive closure is obtained even on frequent cycling or with entrained particulates in the line, unlike other valve types.

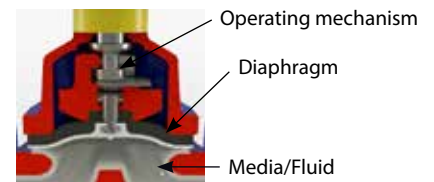

6 Suitable for Control

Throttling and control characteristics are enhanced by a streamlined flow path that is cavity free and provides excellent flow control capabilities.



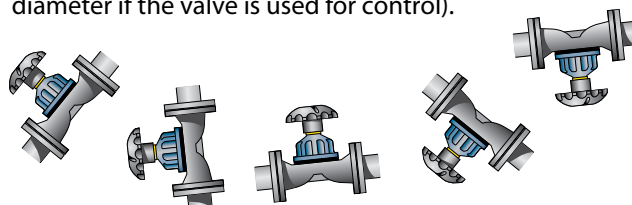

8 Installation Versatility

The Saunders valve can be installed in any position without affecting its operation. However, we recommend installation to be at least six times the pipe diameter from a bend or pump (ten times the pipe diameter if the valve is used for control).

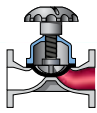

Links to animations depicting the concepts discussed here are available on the Saunders section of the Crane ChemPharma & Energy website.

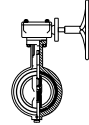
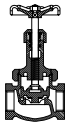
VALVE COMPARISON

Valve/Service Feature	 Diaphragm	 Ball	 Butterfly	 Globe	 Gate	 Lubricated Plug
Leak tight* shut-off against gases, liquids and solids	Green	Yellow	Yellow	Yellow	Yellow	Yellow
Resistance to abrasion and erosion	Green	Yellow	Yellow	Red	Yellow	Yellow
Wide choice of materials to match service conditions	Green	Green	Green	Yellow	Yellow	Yellow
Non-turbulent flow path	Green	Green	Yellow	Red	Green	Green
Low fluid friction loss	Green	Green	Yellow	Red	Green	Green
Resistance to corrosion	Green	Green	Green	Yellow	Yellow	Yellow
Vacuum capability	Green	Green	Yellow	Yellow	Red	Yellow
In-line maintenance, low cost spares	Green	Yellow	Yellow	Red	Red	Yellow
Resistance to seat wear	Green	Red	Red	Green	Yellow	Red
High purity	Green	Yellow	Yellow	Red	Red	Red
Control applications	Green	Yellow	Yellow	Green	Red	Yellow
On/off applications	Green	Green	Green	Yellow	Yellow	Yellow
Temperature range	Yellow	Green	Green	Green	Green	Yellow
Pressure range	Yellow	Green	Green	Green	Green	Green
Weight/size ratio	Yellow	Yellow	Green	Yellow	Yellow	Yellow

Suitable **Not Suitable**

Saunders® offers a comprehensive range of diaphragm valves for use in any industry. They encompass the full spectrum of corrosive and abrasive applications that require reliable valve operation. Easily maintained to ensure many years of trouble-free operation, Saunders® diaphragm valves have become a standard in industries such as chemical production, mining, water treatment, fertilizers and marine.

*in accordance with standards MSS SP-88 and BS EN 12266-1

APPLICATIONS

CORROSIVE

- Chlor-alkali
- Sulfuric Acid
- Hydrochloric Acid
- Nitric Acid
- Aromatics
- Effluent Treatment
- Potable Water
- Pulp & Paper
- Organics
- Toxic Fluids
- Iron and Steel
- Fine Chemicals



"We are pleased to inform that we are using Saunders in our Runcorn chlor-alkali and chlorine derivatives plants. We are very satisfied with the product's reliability, low maintenance costs and with the quality of the technical service. We hope to get the same support in all our future supplies/requirements."

INEOS ChlorVinyls (UK)

Corrosion is estimated to cost worldwide industry more than \$300 billion dollars every year, affecting every process industry sector. Saunders® lined diaphragm valves are the best option to handle these media and therefore reduce the cost of ownership.

Strong Acids

Saunders® Industrial Diaphragm Valves are available in a wide range of linings and are used to handle strong acids such as sulfuric acid, hydrochloric acid, acetic acid and nitric acid. In the most demanding applications, Saunders® valves offer the highest resistance and durability.

Diaphragm reliability, results in long life and simplified maintenance. Saunders® diaphragms achieve this through using the best materials and stringent quality controls.



ETFE lined valve with PTFE diaphragm
Page 15



PFA lined A Type body
Page 15



Glass lined A type body
Page 15



PFA lined valve with PTFE diaphragm and EC actuator

Type	Applications	Body/lining	Diaphragm
C	Strong Acids	ETFE, PVDF, PFA, glass ¹	PTFE
C	Fine Chemicals and Chlor-alkali	Hard natural rubber, glass ¹ , ETFE, PFA	Fluoroelastomer, Chlorosulfonated polyethylene, PTFE

C = Corrosive

¹ Glass is not suitable for applications with thermal cycling. Chemical etching may occur when in contact with hydrofluoric acid or highly concentrated alkali solutions. Please contact Saunders® for precise recommendations.

APPLICATIONS

ABRASIVE

Fertilizers
Titanium dioxide
Phosphate
Copper mining
Gold mining
Sand
Coal slurry
FGD
Cement
Ceramics
Sewage
Sugar

The secret to the reliability and durability of Saunders® valves lies in the careful selection of lining and diaphragm material, according to the application.



The Ultimate XA diaphragm was specially developed for highly corrosive and abrasive applications. Page 25

Applications requiring a combination of corrosion and abrasion resistance, such as phosphate rock/sulfuric acid, together with reliability and long service life are ideal applications for Saunders® KB Valves



Type	Applications	Body/lining	Diaphragm
C / A	Mineral processing	Butyl, soft rubber	Butyl, natural rubber, ultimate XA
C / A	Gypsum (FGD)	Butyl	Butyl, ultimate XA
C / A	Titanium dioxide	Glass, butyl, soft rubber	Butyl, natural rubber
C / A	Fertilizers	Butyl, polychloroprene	Butyl, polychloroprene, ultimate XA
C / A	Paper & pulp	Glass, butyl	EPM, butyl, polychloroprene, ultimate XA
A	China clay	Butyl, soft rubber	Natural rubber, polychloroprene

C = Corrosive, A = Abrasive



Glass lined KB type body
Page 25



Butyl lined KB type body
Page 25

APPLICATIONS

GENERAL INDUSTRY

Water demineralization
Marine
Vegetable oils
Paints
Fire fighting
Tanning
Oil production
Automobile
Air
Effluent
Gases, fuels
Dye fluids
Food & beverage
Wastewater
HVAC

Type	Applications	Body/lining	Diaphragm
G	Water demineralization, desalination, sewage treatment	Hard rubber, soft rubber, butyl	EPM, butyl, polychloroprene, butadiene acrylonitrile
G	Marine, fire fighting ¹	SG iron and gunmetal	Chlorosulfonated polyethylene (fabric reinforced)
G	HVAC, utilities (air, water and gas lines) ² , drinking water	Screwed/flanged unlined valves in iron, stainless steel or gunmetal	EPM, butyl, polychloroprene

G = General Industry

¹ Used primarily as water hydrant valves.

² Used in copper or stainless steel piping in water, oxygen and other gases.

Water treatment

Water demineralization, desalination and basic treatment are ideal applications for diaphragm valves. Valves typically used include unlined cast iron or stainless steel bodies, as well as hard, soft or butyl rubber lined bodies, combined with natural rubber, EPDM or butyl diaphragms.



Marine

We offer a specialized range of valves for marine and fire fighting applications, 100% reliable in adverse conditions even after long idle periods. Available with unique fire resistant diaphragm design.

“We specified Saunders WFB 65mm nominal bore fire-mains hydrant valves for our ferries and cruise liners. Significant factors behind this choice are the excellent reliability and the low maintenance costs.”

P&O Cruise (UK) Ltd



Saunders® WFB valves. Page 33



HVAC and Utilities

Saunders® valves are widely used on utility (air, water and gas) service lines. Screwed unlined valves both A and KB types in cast iron and gunmetal, are used in several water applications – screwed end connections result in a lower valve cost.

Saunders® offers FDA and WRAS approved A and KB type diaphragms and valve linings.

WRAS approval ensures our valves are suitable for potable (drinking) water use.



POLYMER SCIENCE

At Saunders®, we apply rigorous quality control measures at every manufacturing step of our polymer materials. For many years, we have increased our expertise and accumulated experience in the production of our own **diaphragms** and valve **linings**. As a result, our valves can handle the most challenging fluids with total security. The name Saunders® is synonymous with innovation, continuous product development and the highest standards of quality control.



A type, butyl diaphragm



PTFE diaphragm with butyl rubber backing



KB type, soft natural rubber diaphragm



214K diaphragm for high performance in chlorine applications

Fitments Features



Rubber diaphragms Screw fitment



PTFE diaphragms Bayonet fitment

BEST MATERIALS

STRINGENT QUALITY CONTROLS

RELIABILITY, LONG LIFE AND SIMPLIFIED MAINTENANCE

Diaphragm Construction



PTFE Diaphragm

Feature	Benefit
Premium grade raw materials and fabric reinforcement in a multi-layer construction	Maximum performance and durability in the most demanding applications
Studs attached with bonding adhesive and mechanical anchorage	Strength and durability for intensive and systematic mechanical operation
Dual sealing ribs (across the weir and around the diaphragm periphery)	Enhanced leak tight sealing capabilities and lower closure torques
Two-piece diaphragm construction - PTFE face and reinforced rubber backing	Increased pressure rating and durability

Expected shelf life of diaphragm (from manufacturing dates)

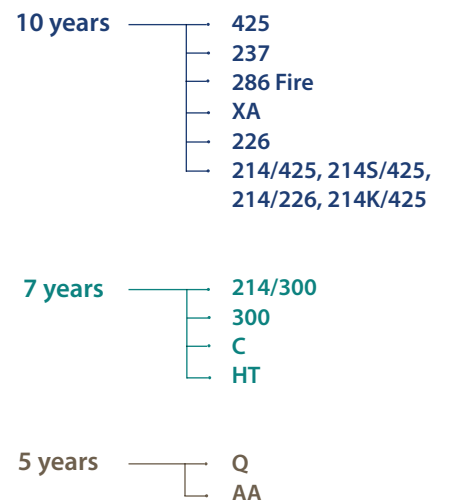

SUPPORTING DATA AND CERTIFICATION

Saunders® Data Sheets

Digital copies of technical data sheets, which provide detailed information on the Saunders® IDV range, can assist with valve selection and are available upon request. Contact your local sales office or distributor for more details on how to obtain the data sheet package.



Data sheet index and typical valve information

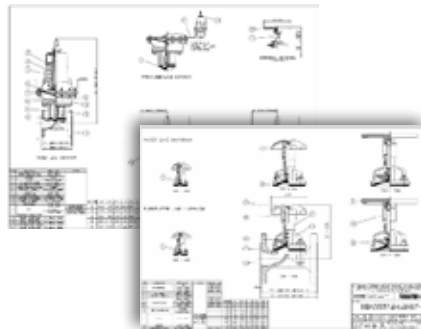

Example of 2D Drawings available on Saunders® website.

Material Compatibility Database

Saunders® has a database of over 800 chemicals, which can be used to aid lining and diaphragm material selection. By selecting the process fluid, temperature and concentration, the suitable material options are identified.



Screenshot of Saunders® Material Compatibility Database

Saunders® 2D Drawings

A library containing technical drawings of the Saunders Industrial Diaphragm Valve and Actuator range is available online at www.saundersdrawings.com.

Quality Statements And Approvals

CERTIFIED QUALITY FROM SAUNDERS®

- Quality Management system registered to ISO 9001 standard in which our R&D and manufacturing process are optimized to maintain our product quality and service
- Certified compliance to the European Pressure Equipment Directive 97/23/EC, authorizing Saunders® to CE mark relevant valve products
- TUV-Merkblatt HPO Qualification for our product manufacturing and certification
- International product approval from authorities such as Bureau Veritas, Lloyds, ABS, RINA and TSG
- Polymer materials certified as meeting the requirements of FDA, USP and WRAS

EXAMPLES OF PRODUCT AND SYSTEM APPROVALS

- ISO 9001
- PED 97/23/EC
- WRAS (Water Regulations Advisory Scheme)
- Lloyds Register of Shipping
- Bureau Veritas
- ATEX Directive (94/9/EC)
- Food & Drug Administration (FDA)
- United States Pharmacopeia (USP)
- Registro Italiano Navale (RINA)



Compliance WITH
FDA Code 21
TNO CERTIFICATION 3A
cGMP USP 23

A TYPE – FEATURES

Original Saunders[®] Design

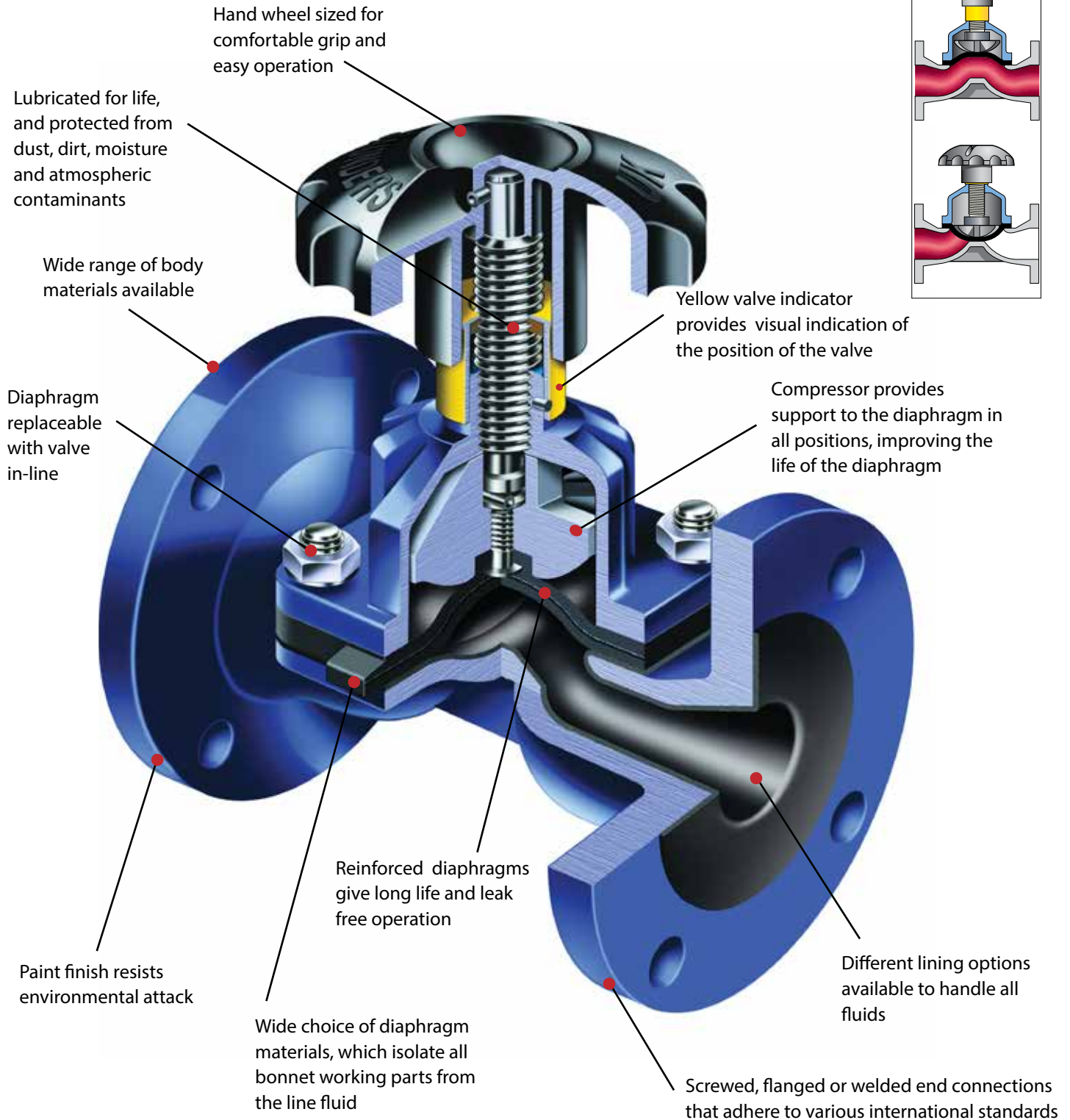

Saunders[®] A type Diaphragm Valve:
the valve of choice to handle highly corrosive media

A TYPE – STANDARDS



Top Works

- Manual
- Actuated

Diaphragm

- Rubber
- PTFE

Body

- Flanged and screwed design
- Lined and unlined
- Cast iron, SG iron, cast steel, stainless steel or gunmetal

As well as meeting the overall lengths specified in EN 558-1 Series 1, Series 7* and MSS SP-88, Saunders® valves are manufactured to the following standards:

Flanged	
American	ASME B16.1 Class 125
	ASME B16.24 Class 150
	ASME B16.5 Class 150
British	BS 10 Tables D and E
British/European¹	BS EN 1092-1 PN10/16
	BS EN 1092-2 PN10/16
	BS EN 1092-3 PN10/16
Japanese	JIS B 2220 10K
	JIS B 2239 10K
	JIS B 2240 10K

¹ Replaces BS 4504 PN10/16

Screwed	
American²	ASME B1.20.1
British/European³	BS EN 10226-1 Parallel
	BS EN 10226-1 Taper
European⁴	EN ISO 228-1
International	ISO 7-1 Parallel
	ISO 7-1 Taper

² Replaces ANSI 2.1

³ Replaces BS 21 Parallel and Taper

⁴ Replaces DIN 259

* Series 7 is the original IDV standard from when PK Saunders invented the diaphragm valve.

A TYPE – BODY

Lined and Unlined Options

Our metal bodies provide simultaneous mechanical support for the lining and protection against Ultraviolet (UV) attack. The nominal bore thicknesses of Saunders® linings range from 1 to 5.5 mm, depending on lining material and valve size: glass 1 mm, rubber 2-4.5 mm and plastic 4-5.5 mm.

Unlined Bodies

Material	Connection	Standard	Material Grade	Size	Temperature
Cast Iron	Flanged	BS EN1561	GJL-250	DN15-DN500	-10°C to 175°C
SG Iron	Screwed	BS EN1563	GJS-450-10	DN8-DN50	-10°C to 175°C
	Flanged		GJS-400-18 ¹	DN15-DN350	
Cast Steel	Flanged	ASTM A216	WCB	DN15-DN250	-30°C to 175°C
Gun Metal	Screwed	BS EN1982	CC491K-GS	DN8-DN80	-30°C to 175°C
	Flanged		CC492K-GS	DN15-DN200	
Stainless Steel	Screwed	BS EN10283	1.4408 ²	DN8-DN80	-30°C to 175°C
	Flanged			DN15-DN200	

¹ For some sizes GJS-400-18-LT grade is available with a low temperature limit of -20°C

² Replaces the standard BS3100 316C16

Standard material grade fasteners:

Stainless steel fasteners - All stainless steel, plastic lined and glass lined valves

Aluminium Bronze fasteners - Gunmetal flanged valves

Carbon Steel fasteners - All remaining valves.

Special material grade fasteners available upon request

Lined Options - Flanged Bodies Only

Lining	Body Material	Size	Temperature
PFA	SG Iron	DN15-DN200	-10°C to 175°C
ETFE	SG Iron	DN15-DN150	-10°C to 150°C
PVDF	SG Iron	DN20-DN150	-10°C to 125°C
PP	SG Iron	DN20-DN150	-10°C to 85°C

Glass	Cast Iron	DN15-DN200	-10°C to 175°C
-------	-----------	------------	----------------

Butyl (Isobutylene Isoprene)	Cast Iron	DN20-DN500	-10°C to 110°C
	SG Iron		-10°C to 110°C
	Cast Steel		-30°C to 110°C
Neoprene (Polychloroprene)	Cast Iron	DN20-DN500	-10°C to 105°C
	SG Iron		-10°C to 105°C
	Cast Steel		-30°C to 105°C
HRL (Hard Natural Rubber)	Cast Iron	DN20-DN500	-10°C to 85°C
	SG Iron		-10°C to 85°C
	Cast Steel		-30°C to 85°C

Plastic Lining



PFA Perfluoroalkoxy – Excellent suitability for concentrated strong acids at high temperature, aromatics, aliphatic and chlorinated solvents. (White colour)



ETFE Ethylene Tetrafluoroethylene – Suitable for strong acids, salts in water, solvents at medium temperature. ETFE has the highest abrasion resistance of all the fluorocarbon linings. (Red colour)



PP Polypropylene – Economic solution for mineral acids, salts in water, de-ionised water and effluent treatment chemicals. (Light grey colour)



PVDF Polyvinylidene Fluoride – Suitable for mineral acids, salts in water, water and effluent treatment, additionally it is the best solution for wet chlorine gas or chlorine in water. (Black colour)



Glass Lining



Used in many different applications, including strong acids. Very high corrosion and abrasion resistance within a wide range of temperature. *Note that glass is not suitable for applications where thermal cycling occurs.* (Blue colour)

Corrosion & Chemical Resistance

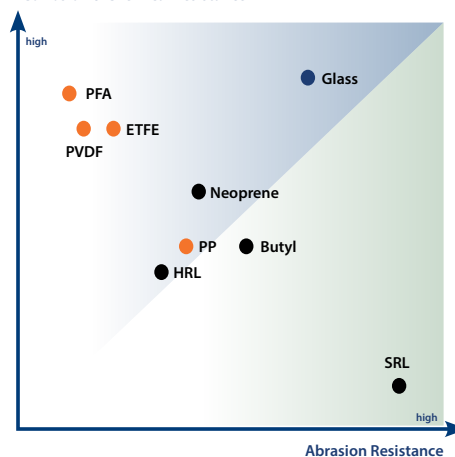

Rubber Lining



HRL Hard Natural Rubber – Used for salts in water, diluted acids, de-ionised water, plating solutions and potable water. HRL has better chemical resistance than SRL. (Black)

Butyl Isobutylene Isoprene – Great for corrosive & abrasive slurries, and acidic slurries. Additional applications are salts in water, dilute acids and alkalis, and lime. (Black)

Neoprene Polychloroprene – Perfect solution for a combination of abrasive slurries containing hydrocarbons, sludge oils and also sea water. (Black)

The temperature ranges above are given for general reference purposes only. Service conditions, such as media being handled and concentration of solids, will determine the highest possible working temperature. Additionally, the performance of the valve will also depend on the diaphragm material.

A TYPE – DIAPHRAGM

A Type Diaphragm

Diaphragm	Composition	Size	Temperature
425	EPM (Ethylene Propylene)	All Sizes	-40°C to 130°C
300	Butyl (Isobutylene Isoprene)	All Sizes	-40°C to 130°C
237	CSM (Chlorosulfonated Polyethylene)	All Sizes	-10°C to 100°C
XA	EPDM (Ethylene Propylene Diene)	All Sizes	-40°C to 130°C
HT	Neoprene (Polychloroprene)	All Sizes	-30°C to 100°C
226	FKM (Fluoroelastomer)	All Sizes	-5°C to 150°C
C	Nitrile (Butadiene Acrylonitrile)	All Sizes	-20°C to 100°C
Q	Natural Rubber	All Sizes	-50°C to 100°C

214/300	PTFE/Butyl	DN8-DN250	-20°C to 150°C
214/425	PTFE/EPM	DN8-DN250	-20°C to 160°C
214/226	PTFE/FKM	DN8-DN250	-5°C to 175°C
214S/425	TFM/EPM	DN8-DN150	-20°C to 160°C
214K/425	PTFE/PVDF/EPM	DN15-DN150	-20°C to 100°C

In the range of PTFE diaphragms, Saunders offers both moulded open and closed options for your convenience. The 214S is available as moulded closed and was designed specifically to reduce polymeric creep, therefore increasing the sealing properties and life of the diaphragm.



Moulded closed



Moulded open

PTFE Diaphragm

214/300 - Used in strong acids and alkalis, and salts in water at high temperature. Sulfuric acid is a good example with temperatures up to 110°C and concentrations up to 96 %.

214/425 - Typical applications are strong acids, alkalis and salts in water at high temperature. Constant steam is also another important application.

214/226 - Strong acid, diluted chlorine, bromine solutions at low concentration.

214S/425 - Strong acids, alkalis and salts in water at high temperature. Constant steam applications where the valve is mainly closed (diaphragm is moulded closed).

214K/425 - Three layer diaphragm with PTFE/PVDF/425, the best option for chlorine, bromine gas and chlorinated solutions.

Rubber Diaphragm

425 - Salts in water, acids and alkalis, ozone, water, intermittent steam. Great solution for food and beverages applications. FDA and USP approved¹.

300 - Chemicals, diluted acids and alkalis, drinking water. Additional abrasive applications like phosphoric acid in low concentrations. FDA, USP and WRAS approved¹.

237 - The best solution for sodium hypochlorite. Great with strong acids and low concentration chlorine gas. It is also oil resistant.

XA - Specifically designed for both abrasive and corrosive applications such as phosphoric acid, metal treatment, mining applications.

HT - Suitable for abrasive slurries containing hydrocarbons.

226 - Great solution for hydrogen at high temperature, concentrated acids, aromatic solvents, low concentrated chlorine solutions, ozone, unleaded petroleum.

C - Lubricating oil, cutting oils, paraffin, animal vegetable oils, aviation kerosene at low temperatures. Cv is ideal for vacuum applications, where oils are present, e.g. (compressed air, acetylene gas, LPG).

Q - Salts in water, diluted acids and alkalis, and abrasive applications.

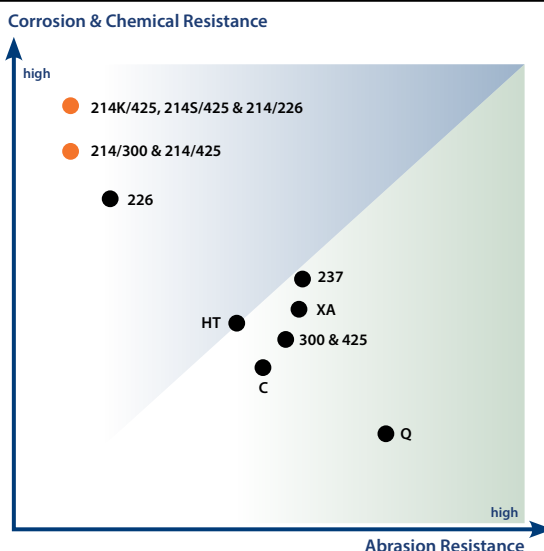

¹ FDA - Food and Drug Administration

USP - United States Pharmacopeia

WRAS - Water Regulations Advisory Scheme

All rubber diaphragms have threaded brass fixings, except vacuum diaphragm (Cv, 300v, 425v), which have steel fitments. PTFE diaphragms have a stainless steel bayonet fitments.

A TYPE – DIAPHRAGM DIMENSIONS

Diaphragm Identification

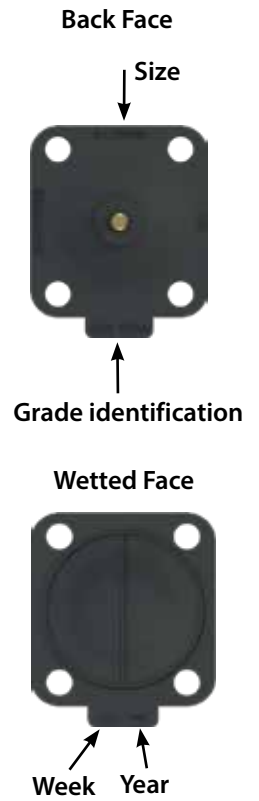
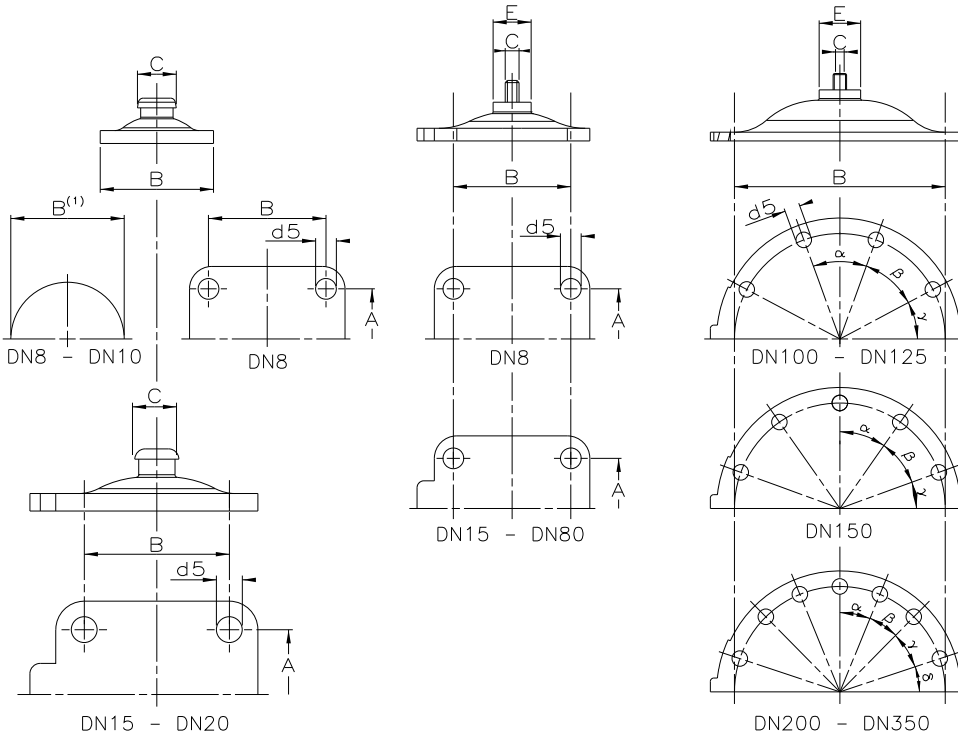

Size (DN)	Principal Diaphragm Dimensions							Angles from the holes			
	A	B	C	D (thickness)	E	d5	Number of Holes	α	β	γ	δ
8	35	28	9.5	3.2	-	5	2	-	-	-	-
10	43	35	10	4	-	6	2	-	-	-	-
15	33	37	13	5	-	6	4	-	-	-	-
20	40	44	13	5.4	-	7	4	-	-	-	-
25	46	54	1/4" BSW	5.5	17.5	10	4	-	-	-	-
32	60	67		7.2	19	10	4	-	-	-	-
40	65	70		6	22	11	4	-	-	-	-
50	78	83	5/16" BSW	6.2	25.4	13	4	-	-	-	-
65	95	102		7.9	28.6	14	4	-	-	-	-
80	114	127	3/8" BSW	7	32	17	4	-	-	-	-
100	-	194		8	38	14	4	40°	42°	56°	-
125	-	222	3/8" BSW	11.1	44.5	17	8	43°20'	43°20'	50°	-
150	-	273		11.9	50	17	8	35°	35°	40°	-
200	-	381	7/8" BSW	10	63.5	19	10	22°30'	22°30'	27°	36°
250	-	438		14	76	22	14	22°30'	22°30'	22°30'	45°
300	-	508		15.2	89	25	14	24°	24°	24°	36°
350	-	527		15.9							

BSW=British Standard Whitworth thread

Note: Dimensions in mm unless otherwise stated.

A TYPE – TOP WORKS

Standard Range

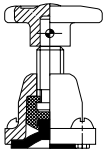

Rising handwheel (2 bolt)
DN8 - DN10

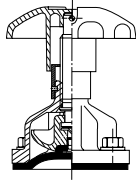

Cast iron bonnet with rising plastic handwheel
DN15 - DN50

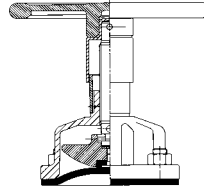

Cast iron bonnet with rising metal handwheel
DN15 - DN150

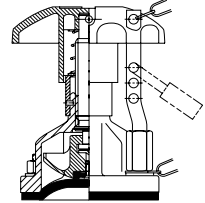

Rising handwheel with indicator (simple padlocking)
DN15 - DN150

High Performance

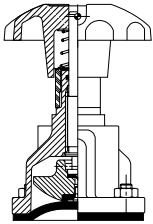

Fluoroelastomer sealed bonnet
DN15 - DN150

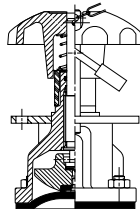

Fluoroelastomer sealed with padlocking
DN15 - DN150

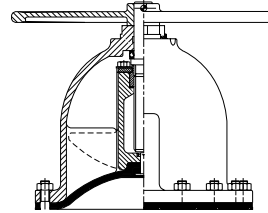

Standard non-rising handwheel without indicator
DN200 - DN350

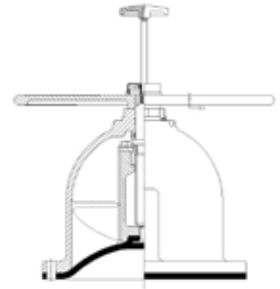

Non-Rising handwheel with indicator
DN200 - DN350

Note: Designs may vary across size range

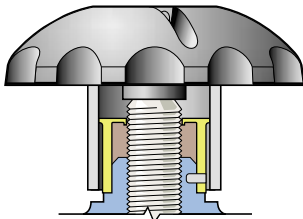

Lubrication
Bonnet assembly lubricated for life. Needs no additional grease. The indicator lip seal stops the ingress of dust, dirt and atmospheric contaminants.

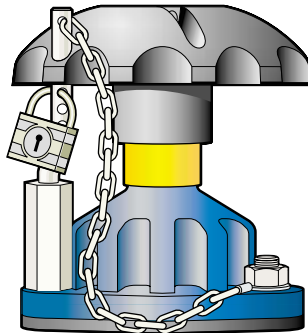

Padlock Bonnet
Restricted valve operation can be achieved by utilizing the padlocking bonnet option.

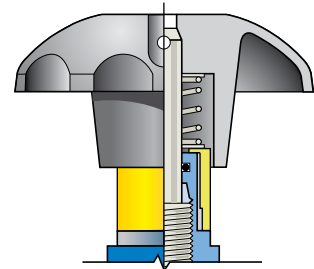

Sealed Bonnet
In cases where hazardous liquids or gases are being handled and where additional safety features are considered to be necessary.

A TYPE – PRESSURE & TEMPERATURE LIMITS

Maximum manual working pressures for Saunders[®] A type diaphragm valves.
For actuated valves, please refer to the appropriate datasheets.

Bonnet pressure limits

		Size (DN)	8	10	15	20	25	32	40	50	65	80	100	125	150	200	250	300	350	
Pressure (bar)	Diaphragm	Handwheel																		
		PTFE	Rising	10	10	10	10	10	10	10	10	10	10	10	10	10	7	-	-	-
	PTFE	Non-rising	-	-	-	-	-	-	-	-	-	-	-	-	-	-	6	5	-	-
	Rubber	Rising	16	16	16	16	16	16	16	16	16	10	10	10	10	10	-	-	-	-
Rubber	Non-rising	-	-	-	-	-	-	-	-	-	-	-	-	-	-	6	5	4	3.5	

All Saunders[®] valves are pressure tested in accordance with BS EN12266-1 standard.

- Shell test: 1.5 times maximum rated working pressure
- Seat test: 1.1 times maximum rated working pressure

Pressure/Temperature Relationships

Cast Iron and SG Iron

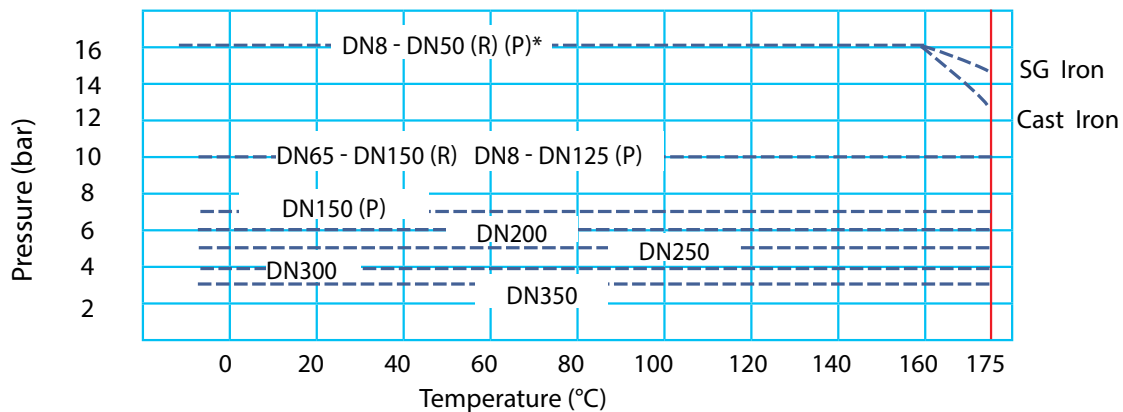

Carbon Steel, Stainless Steel & Gunmetal

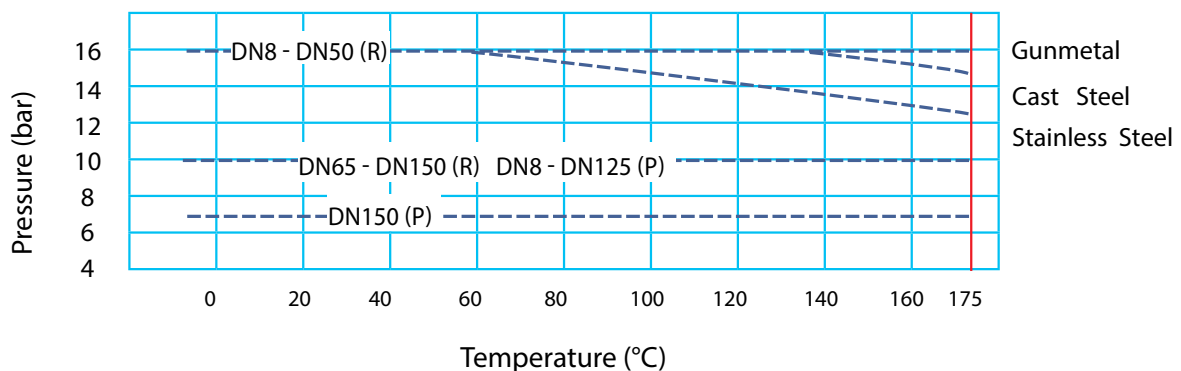

(R) = Rubber diaphragm
(P) = PTFE diaphragm
* 214S Moulded closed version only

A TYPE – ASSEMBLED VALVE DIMENSIONS

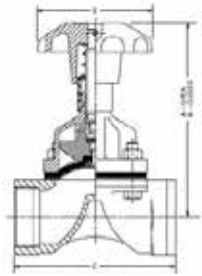

Screwed DN8-DN80

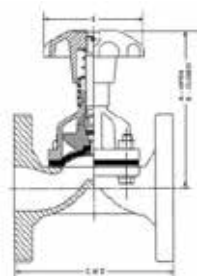

Flanged DN15-DN50

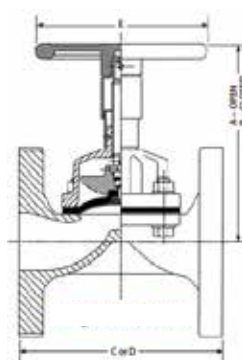

Flanged DN65-DN150

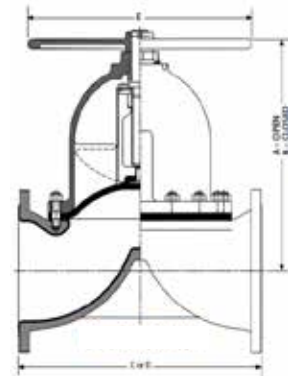

Flanged DN200-DN350

Size (DN)	8	10	15	20	25	32	40	50	65	80	100	125	150	200	250	300	350	
Screwed Unlined	A	54	67	90	94	119	154	164	188	241	263	-	-	-	-	-	-	
	B	52	61	84	88	108	142	148	164	209	229	-	-	-	-	-	-	
	C	49	49	64	83	111	125	145	168	206	257	-	-	-	-	-	-	
	Weight	0.11	0.15	0.45	0.9	1.13	1.8	3	5	9	13	-	-	-	-	-	-	
Flanged Unlined	A	-	-	100	91	108	143	157	175	226	243	308	388	442	495	581	679	660
	B	-	-	93	85	98	131	141	152	194	208	262	322	367	495	581	679	660
	C	-	-	108	117	127	146	159	190	216	254	305	356	406	521	635	749	749
	D	-	-	130	150	160	180	200	230	290	310	350	400	480	600	730	850	980
	Weight	-	-	2	2	3	4	5	8	14	19	32	48	63	152	270	360	506
Flanged Rubber Lined	A	-	-	-	97	111	146	160	177	229	246	311	391	445	498	585	683	664
	B	-	-	-	91	101	134	144	154	197	212	265	325	370	498	585	683	664
	C	-	-	-	121	131	150	163	194	220	258	309	362	412	527	641	755	755
	D	-	-	-	150	160	180	200	230	290	310	350	400	480	600	730	850	980
	Weight	-	-	-	3	4	5	6	9	15	21	32	50	63	154	273	365	512
Flanged Glass/Halar Lined	A	-	-	101	92	109	144	158	176	227	244	309	389	443	496	582	680	661
	B	-	-	94	86	99	132	142	153	195	210	263	323	368	496	582	680	661
	C	-	-	110	119	129	148	161	192	218	256	307	358	408	523	637	751	751
	D	-	-	130	150	160	180	200	230	290	310	350	400	480	600	730	850	980
	Weight	-	-	2	2	4	5	6	9	15	20	33	49	63	153	272	362	508
Flanged Plastic Lined	A	-	-	-	97	112	147	162	179	230	246	313	391	450	-	-	-	-
	B	-	-	-	91	101	133	145	155	198	211	267	322	374	-	-	-	-
	C	-	-	-	123	133	152	165	196	222	260	311	356	412	-	-	-	-
	D	-	-	-	150	160	180	200	230	290	310	350	394	480	-	-	-	-
	Weight	-	-	-	3	4	5	6	9	15	21	34	50	63	-	-	-	-
E	38	50	62	62	80	120	120	120	170	230	280	280	368	482	584	699	699	

Note: Dimensions in mm. Weights in kg. Weight may vary with materials, lining and standards. For exact weights please contact Saunders®. C valve length = EN 558 Series 7 (ex BS 5156). D valve length = EN 558 Series 1 (ex DIN 3202 Series F1).

Glass lining is typically available in the size range DN15 - DN200 for A Type valves. Contact Saunders® for further requirements.

A TYPE – FLOW COEFFICIENTS

DN15								
% Open	Body Material / Lining							
	Cast (Unlined)		Rubber Lined		Glass / Halar		Plastic Lined	
	Cv	Kv	Cv	Kv	Cv	Kv	Cv	Kv
100	5.5	4.8	-	-	6.0	5.2	-	-
90	5.3	4.6	-	-	5.8	5.0	-	-
80	5.1	4.4	-	-	5.5	4.8	-	-
70	4.8	4.2	-	-	5.3	4.6	-	-
60	4.6	4.0	-	-	5.0	4.4	-	-
50	3.8	3.3	-	-	4.2	3.6	-	-
40	3.1	2.7	-	-	3.4	2.9	-	-
30	2.3	2.0	-	-	2.5	2.2	-	-
20	1.5	1.3	-	-	1.7	1.4	-	-
10	0.8	0.7	-	-	0.8	0.7	-	-
0	0	0	-	-	0	0	-	-

DN20								
% Open	Body Material / Lining							
	Cast (Unlined)		Rubber Lined		Glass / Halar		Plastic Lined	
	Cv	Kv	Cv	Kv	Cv	Kv	Cv	Kv
100	12	9.9	9.2	8.0	12	10	6.5	6
90	11	9.5	9.0	7.8	12	10	6.2	5
80	11	9.1	8.8	7.6	11	9.5	6.0	5
70	10	8.8	8.4	7.3	11	9.1	5.7	5
60	9.7	8.4	7.7	6.7	10	8.7	5.5	5
50	8.1	7.0	6.7	5.8	8.4	7.3	4.5	4
40	6.4	5.6	5.5	4.8	6.7	5.8	3.6	3
30	4.8	4.2	4.1	3.5	5.0	4.4	2.7	2
20	3.2	2.8	2.5	2.2	3.4	2.9	1.8	2
10	1.6	1.4	1.0	0.9	1.7	1.4	0.9	1
0	0	0	0	0	0	0	0	0

DN25								
% Open	Body Material / Lining							
	Cast (Unlined)		Rubber Lined		Glass / Halar		Plastic Lined	
	Cv	Kv	Cv	Kv	Cv	Kv	Cv	Kv
100	18	15	14	12	18	16	11	9.7
90	16	14	14	12	17	15	11	9.3
80	16	14	13	12	17	14	10	8.9
70	15	13	13	11	16	14	9.9	8.5
60	15	13	12	10	15	13	9.4	8.1
50	12	11	10	9	13	11	7.8	6.8
40	9.9	8.5	8.4	7.3	10	8.7	6.3	5.4
30	7.4	6.4	6.3	5.4	7.6	6.5	4.7	4.1
20	4.9	4.3	3.8	3.3	5.0	4.4	3.1	2.7
10	2.5	2.1	1.5	1.3	2.5	2.2	1.6	1.3
0	0	0	0	0	0	0	0	0

DN32								
% Open	Body Material / Lining							
	Cast (Unlined)		Rubber Lined		Glass / Halar		Plastic Lined	
	Cv	Kv	Cv	Kv	Cv	Kv	Cv	Kv
100	28	24	22	19	28	24	17	14
90	26	23	21	18	27	23	16	14
80	25	22	20	18	26	22	15	13
70	24	21	19	17	25	21	15	13
60	23	20	18	16	24	20	14	12
50	19	17	15	13	20	17	12	10
40	15	13	12	11	16	14	9.4	8.1
30	12	10	9.2	8.0	12	10	7.0	6.1
20	7.7	6.7	6.2	5.3	7.8	6.8	4.7	4.0
10	3.8	3.3	3.1	2.7	3.9	3.4	2.3	2.0
0	0	0	0	0	0	0	0	0

DN40								
% Open	Body Material / Lining							
	Cast (Unlined)		Rubber Lined		Glass / Halar		Plastic Lined	
	Cv	Kv	Cv	Kv	Cv	Kv	Cv	Kv
100	43	37	35	30	45	39	31	27
90	41	36	34	29	43	37	30	26
80	40	34	34	29	41	36	29	25
70	38	33	32	28	40	34	27	24
60	36	31	29	25	38	33	26	23
50	30	26	26	22	32	27	22	19
40	24	21	21	18	25	22	17	15
30	18	16	16	14	19	16	13	11
20	12	10	9.5	8.2	13	11	8.7	7.5
10	6.0	5.2	3.9	3.4	6.3	5.4	4.3	3.7
0	0	0	0	0	0	0	0	0

DN50								
% Open	Body Material / Lining							
	Cast (Unlined)		Rubber Lined		Glass / Halar		Plastic Lined	
	Cv	Kv	Cv	Kv	Cv	Kv	Cv	Kv
100	80	69	64	55	88	76	59	51
90	77	66	63	54	84	73	56	48
80	74	64	61	53	81	70	54	47
70	70	61	58	50	77	67	52	45
60	67	58	53	46	74	64	50	43
50	56	48	47	41	62	53	41	35
40	45	39	38	33	49	43	33	29
30	34	29	29	25	37	32	25	22
20	22	19	17	15	25	21	16	14
10	11	9.7	7.0	6.1	12	11	8.0	6.9
0	0	0	0	0	0	0	0	0

DN65								
% Open	Body Material / Lining							
	Cast (Unlined)		Rubber Lined		Glass / Halar		Plastic Lined	
	Cv	Kv	Cv	Kv	Cv	Kv	Cv	Kv
100	127	110	102	88	132	114	83	72
90	121	105	98	85	126	109	80	69
80	116	100	94	81	121	105	76	66
70	111	96	90	78	116	100	73	63
60	106	92	86	74	110	95	70	60
50	89	77	71	62	92	80	58	50
40	71	62	57	49	74	64	47	40
30	53	46	43	37	55	48	35	30
20	36	31	29	25	37	32	23	20
10	18	15	14	12	19	16	12	10
0	0	0	0	0	0	0	0	0

DN80								
% Open	Body Material / Lining							
	Cast (Unlined)		Rubber Lined		Glass / Halar		Plastic Lined	
	Cv	Kv	Cv	Kv	Cv	Kv	Cv	Kv
100	185	160	148	128	186	161	148	128
90	177	153	145	125	178	154	142	123
80	170	147	142	123	171	148	136	118
70	162	140	135	117	163	141	130	113
60	155	134	123	106	156	135	124	107
50	129	112	108	93	130	113	103	89
40	103	89	89	77	104	90	83	72
30	78	67	67	58	78	68	62	54
20	52	45	40	35	52	45	41	36
10	26	22	16	14	26	23	20	18
0	0	0	0	0	0	0	0	0

DN100								
% Open	Body Material / Lining							
	Cast (Unlined)		Rubber Lined		Glass / Halar		Plastic Lined	
	Cv	Kv	Cv	Kv	Cv	Kv	Cv	Kv
100	315	273	252	218	336	291	270	234
90	302	261	247	214	322	279	259	224
80	289	250	242	203	309	267	248	215
70	277	240	229	198	295	255	237	205
60	264	228	209	181	282	244	226	196
50	220	190	184	159	235	203	189	164
40	176	152	151	131	188	163	151	131
30	132	114	113	98	141	122	113	98
20	88	73	68	59	94	81	76	65
10	44	38	28	24	47	41	38	33
0	0	0	0	0	0	0	0	0

Cv = flow in US gal/min through a valve with ΔP = 1 psi

Kv = flow in m³/hr through a valve with ΔP = 1 bar

$$1.156 Kv = Cv$$

Note: All Kv and Cv values shown here refer to flanged valves. Valves with screwed ends demonstrate different Kv/Cv values. For more information contact Saunders®.

A TYPE – FLOW COEFFICIENTS

DN125									
% Open	Body Material / Lining								
	Cast (Unlined)		Rubber Lined		Glass / Halar		Plastic Lined		
	Cv	Kv	Cv	Kv	Cv	Kv	Cv	Kv	
100	420	363	363	314	440	381	-	-	
90	403	349	348	301	422	365	-	-	
80	386	334	333	288	404	349	-	-	
70	369	319	319	276	387	335	-	-	
60	352	304	304	263	369	319	-	-	
50	294	254	254	220	308	266	-	-	
40	235	203	203	176	246	213	-	-	
30	176	152	152	131	184	159	-	-	
20	117	101	101	87	123	106	-	-	
10	59	51	51	44	62	54	-	-	
0	0	0	0	0	0	0	-	-	

DN150									
% Open	Body Material / Lining								
	Cast (Unlined)		Rubber Lined		Glass / Halar		Plastic Lined		
	Cv	Kv	Cv	Kv	Cv	Kv	Cv	Kv	
100	605	523	484	419	630	545	505	437	
90	580	502	474	410	604	522	484	419	
80	556	481	465	402	579	501	464	401	
70	532	460	440	381	554	479	444	384	
60	508	439	402	348	529	458	424	367	
50	423	366	353	305	441	381	353	305	
40	338	292	290	251	352	304	282	244	
30	254	220	218	189	264	228	212	183	
20	169	146	131	113	176	152	141	122	
10	85	74	53	46	88	76	71	61	
0	0	0	0	0	0	0	0	0	

DN200									
% Open	Body Material / Lining								
	Cast (Unlined)		Rubber Lined		Glass / Halar		Plastic Lined		
	Cv	Kv	Cv	Kv	Cv	Kv	Cv	Kv	
100	1300	1125	1309	1132	1320	1142	-	-	
90	1248	1080	1256	1087	1267	1096	-	-	
80	1196	1035	1204	1042	1214	1050	-	-	
70	1144	990	1151	996	1161	1004	-	-	
60	1092	945	1099	951	1108	958	-	-	
50	910	787	916	792	924	799	-	-	
40	728	630	733	634	739	639	-	-	
30	546	472	549	475	554	479	-	-	
20	364	315	366	317	369	319	-	-	
10	182	157	183	158	184	159	-	-	
0	0	0	0	0	0	0	-	-	

DN250									
% Open	Body Material / Lining								
	Cast (Unlined)		Rubber Lined		Glass / Halar ¹		Plastic Lined		
	Cv	Kv	Cv	Kv	Cv	Kv	Cv	Kv	
100	1980	1713	2000	1730	2100	1817	-	-	
90	1900	1644	1920	1661	2016	1744	-	-	
80	1821	1575	1840	1592	1932	1671	-	-	
70	1742	1507	1760	1522	1848	1599	-	-	
60	1663	1439	1679	1452	1763	1525	-	-	
50	1386	1199	1400	1211	1470	1272	-	-	
40	1108	958	1120	969	1176	1017	-	-	
30	831	719	839	726	881	762	-	-	
20	554	479	560	484	588	509	-	-	
10	277	240	280	242	294	254	-	-	
0	0	0	0	0	0	0	-	-	

DN300									
% Open	Body Material / Lining								
	Cast (Unlined)		Rubber Lined		Glass / Halar ¹		Plastic Lined		
	Cv	Kv	Cv	Kv	Cv	Kv	Cv	Kv	
100	2550	2206	2600	2249	2700	2336	-	-	
90	2448	2118	2496	2159	2592	2242	-	-	
80	2346	2029	2392	2069	2484	2149	-	-	
70	2244	1941	2288	1979	2376	2055	-	-	
60	2142	1853	2184	1889	2268	1962	-	-	
50	1785	1544	1820	1574	1890	1635	-	-	
40	1428	1235	1456	1260	1512	1308	-	-	
30	1071	926	1092	945	1134	981	-	-	
20	714	618	728	630	756	654	-	-	
10	357	309	364	315	378	327	-	-	
0	0	0	0	0	0	0	-	-	

DN350									
% Open	Body Material / Lining								
	Cast (Unlined)		Rubber Lined		Glass / Halar ¹		Plastic Lined		
	Cv	Kv	Cv	Kv	Cv	Kv	Cv	Kv	
100	3700	3201	3750	3244	3880	3356	-	-	
90	3552	3073	3500	3028	3724	3221	-	-	
80	3404	2945	3450	2984	3569	3087	-	-	
70	3256	2817	3300	2855	3414	2953	-	-	
60	3107	2688	3149	2724	3259	2819	-	-	
50	2590	2240	2625	2271	2716	2349	-	-	
40	2072	1792	2100	1817	2172	1879	-	-	
30	1553	1343	1574	1362	1629	1409	-	-	
20	1036	896	1050	908	1086	939	-	-	
10	518	448	525	454	543	470	-	-	
0	0	0	0	0	0	0	-	-	

¹ Glass lining is typically available in the size range DN15 - DN200 for A Type valves. Contact Saunders[®] for further requirements.

Cv = flow in US gal/min through a valve with $\Delta P = 1$ psi

Kv = flow in m³/hr through a valve with $\Delta P = 1$ bar

$$1.156 Kv = Cv$$

Variations in Flow Coefficients (Cv and Kv) ratings can be derived depending on the test method used. The flow coefficient provides a measure of the flow capacity of a valve. It is defined as the volume flow of water at a controlled temperature and a given pressure drop across the valve. This coefficient allows engineers to compare flow capacities of valves of different sizes, types and manufacturers.

KB TYPE – FEATURES

Saunders® KB Design

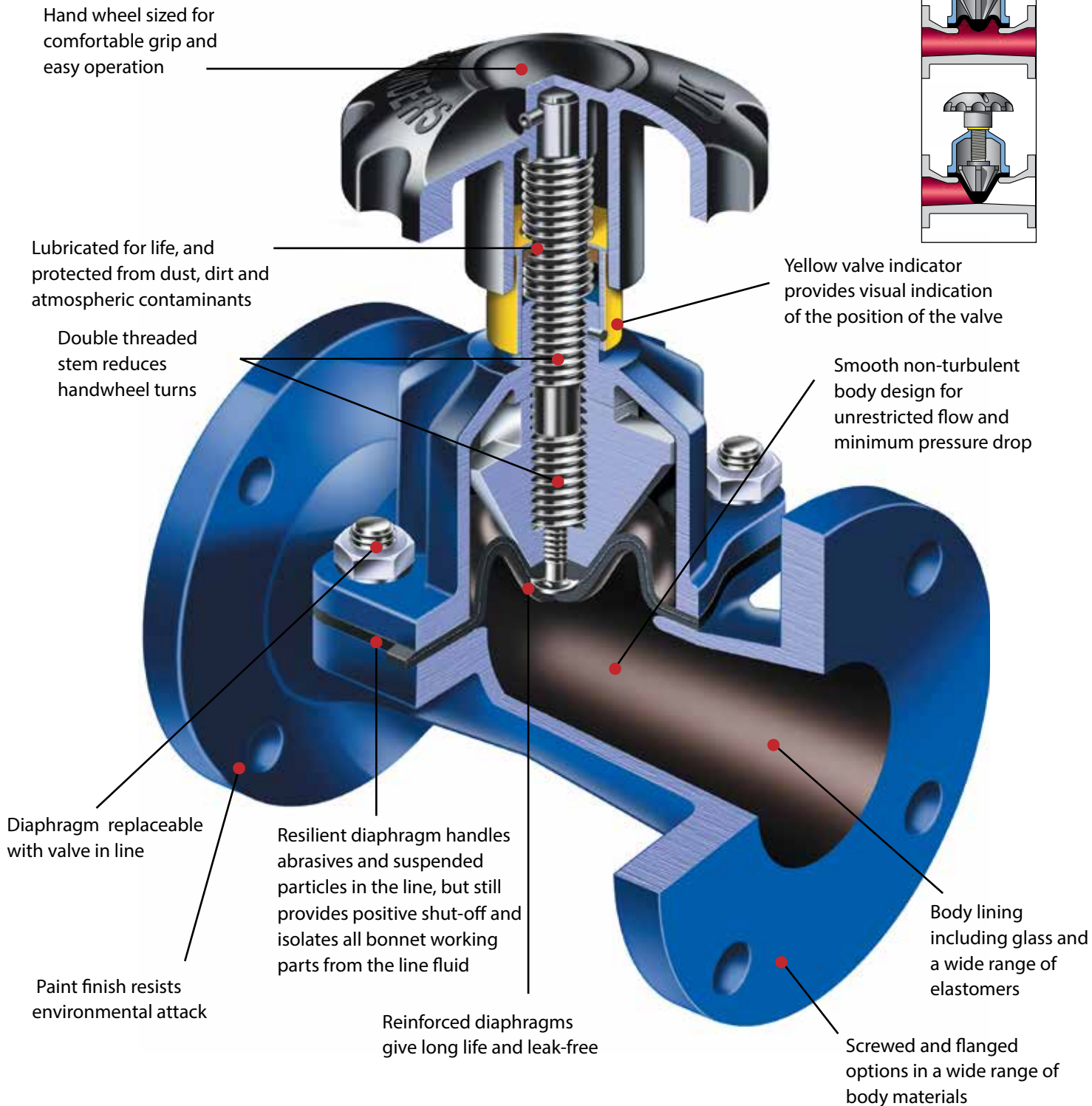

**Saunders® KB and K type (higher flow) valves:
the choice for corrosive slurry applications**

KB TYPE – STANDARDS



Top Works

- Manual
- Actuated

Diaphragm

- Rubber

Body

- Flanged and screwed design
- Lined and unlined
- Cast iron, SG iron, cast steel, stainless steel or gunmetal

As well as meeting the overall lengths specified in EN 558-1 Series 1, Series 7* and MSS SP-88, Saunders® valves are manufactured to the following standards:

Flanged	
American	ASME B16.1 Class 125
	ASME B16.24 Class 150
	ASME B16.5 Class 150
British	BS 10 Tables D and E
British/European¹	BS EN 1092-1 PN10/16
	BS EN 1092-2 PN10/16
	BS EN 1092-3 PN10/16
Japanese	JIS B 2220 10K
	JIS B 2239 10K
	JIS B 2240 10K

¹ Replaces BS 4504 PN10/16

Screwed	
American²	ASME B1.20.1
British/European³	BS EN 10226-1 Parallel
	BS EN 10226-1 Taper
European⁴	EN ISO 228-1
International	ISO 7-1 Parallel
	ISO 7-1 Taper

² Replaces ANSI 2.1

³ Replaces BS 21 Parallel and Taper

⁴ Replaces DIN 259

* Series 7 is the original IDV standard from when PK Saunders invented the diaphragm valve.

KB TYPE – BODY

Lined and Unlined Options

Saunders® full bore KB type diaphragm valves, with their smooth non-turbulent body design, have proven to be outstanding in resisting the erosion effect of abrasive media, providing low pressure drop and high flow characteristics.

Unlined Bodies

Material	Connection	Standard	Material Grade	Size	Temperature
Cast Iron	Screwed	BS EN1561	GJL-250	DN15-DN50	-10°C to 175°C
	Flanged			DN15-DN350	
SG Iron ¹	Screwed	BS EN1563	GJS-450-10	DN8-DN50	-10°C to 175°C
	Flanged		GJS-400-18 ¹	DN15-DN350	
Gun Metal	Screwed	BS EN1982	CC491K-GS	DN15-DN50	-30°C to 175°C
	Flanged		CC492K-GS	DN15-DN100	
Stainless Steel	Flanged	BS EN10283	1.4408 ²	DN15-DN250	-30°C to 175°C

¹ For some sizes GJS-400-18-LT grade is available with a low temperature limit of -20°C

² Replaces the standard BS3100 316C16

Standard material grade fasteners:

Stainless steel fasteners - All stainless steel, plastic lined and glass lined valves

Aluminium Bronze fasteners - Gunmetal flanged valves

Carbon Steel fasteners - All remaining valves.

Special material grade fasteners available upon request

The flexible diaphragms ensure consistent leak tightness even when solids, powders and dry media are present. The wide range of lining materials make the valve suitable for many corrosive/abrasive applications up to a maximum pressure of 10 bar.

Lined Options - Flanged Bodies Only

Lining	Body Material	Size	Temperature
Butyl (Isobutylene Isoprene)	Cast Iron	DN25-DN350	-10°C to 110°C
	SG Iron		-10°C to 110°C
	Cast Steel		-30°C to 110°C
Neoprene (Polychloroprene)	Cast Iron	DN25-DN350	-10°C to 105°C
	SG Iron		-10°C to 105°C
	Cast Steel		-30°C to 105°C
HRL (Hard Natural Rubber)	Cast Iron	DN25-DN350	-10°C to 85°C
	SG Iron		-10°C to 85°C
	Cast Steel		-30°C to 85°C
SRL (Soft Natural Rubber)	Cast Iron	DN25-DN350	-10°C to 85°C
	SG Iron		-10°C to 85°C
	Cast Steel		-30°C to 85°C

Glass	Cast Iron	DN15-DN150	-10°C to 175°C
-------	-----------	------------	----------------

Glass Lining

Used in many different applications, including strong acids, salts and halogenated gases. Superior corrosion and abrasion resistance within a wide range of temperatures and concentrations. *Note that glass is not suitable for applications where thermal cycling occurs.* (Blue)

Rubber Lining

Butyl Isobutylene Isoprene — Great for corrosive and abrasive slurries, and acidic slurries. Additional applications are salts in water, dilute acids and alkalis, and lime. WRAS approved. (Black)

Neoprene Polychloroprene — Perfect solution for a combination of abrasive slurries containing hydrocarbons, sludge oils and also sea water. (Black)

Corrosion & Chemical Resistance

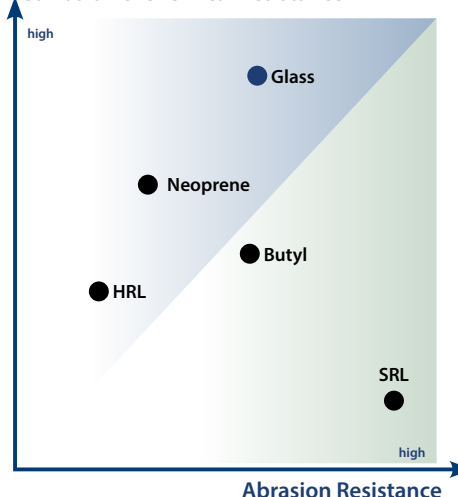

Rubber Lining

HRL Hard Natural Rubber — Used for salts in water, diluted acids, de-ionised water, plating solutions and potable water. HRL has better chemical resistance than SRL. (Black)

SRL Soft Natural Rubber — High abrasion resistance on powders, abrasive slurries, clays, coal dust, dry fertilizers, gypsum, as well as titanium dioxide and sewage. (Brown)

The temperature ranges above are given for general reference purposes only. Service conditions, such as media being handled and concentration of solids will determine the highest possible working temperature. Additionally, the performance of the valve will also depend on the diaphragm material.

The nominal bore thicknesses of Saunders® linings range from 1 to 5.5 mm, depending on lining material and valve size: glass 1 mm, rubber 2-4.5 mm and plastic 4-5.5 mm.

KB TYPE – DIAPHRAGM

Diaphragm

Many factors can accelerate the aging of polymer compounds. Temperature and abrasion have a significant impact on the effect of chemicals on rubber compounds. At Saunders®, we are proud of our core competence, the in-house manufacture of Saunders® diaphragms. Our expertise in polymer science assures the best range of diaphragms to suit the most challenging duties with total security. This explains why Saunders® diaphragms are a synonym with longer life, reduced maintenance and higher plant operating efficiencies.

Energising ribs allow efficient shut-off in wide-bore applications



Rubber Diaphragm

226 - Great solution for hydrogen at high temperature, concentrated acids, aromatics solvents, low concentrated chlorine solutions, ozone, unleaded petroleum.

300 - Chemicals, diluted acids and alkalis, drinking water. Additional abrasive applications like phosphoric acid with low concentration. FDA, USP and WRAS approved¹.

HT - Suitable for abrasive slurries containing hydrocarbons.

425 - Salts in water, acids and alkalis, ozone, water, intermittent steam. Great solution for on food and beverages applications. FDA and USP approved¹.

237 - The best solution for sodium hypochlorite. Great with strong acids and low concentration chlorine gas. It is also oil resistant.

XA - Specifically designed for both abrasive and corrosive application such as phosphoric acid, metal treatment and mining applications.

C - Lubricating oil, cutting oils, paraffin, animal vegetable oils and aviation kerosene at low temperatures.

AA - Excellent choice on abrasive applications such as slurries. The diaphragm has a light brown colour, and is sulfur cured.

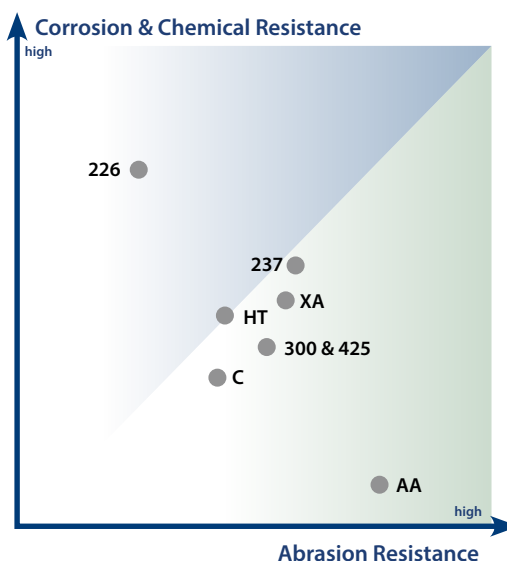

KB Type Diaphragm

Diaphragm	Composition	Size	Temperature
425	EPM (Ethylene Propylene)	All sizes	-40°C to 130°C
300	Butyl (Isobutylene Isoprene)	All sizes	-40°C to 130°C
237	CSM (Chlorosulfonated Polyethylene)	All sizes	-10°C to 100°C
XA	EPDM (Ethylene Propylene Diene)	All sizes	-40°C to 130°C
HT	Neoprene (Polychloroprene)	All sizes	-30°C to 100°C
226	FKM (Fluoroelastomer)	DN15-DN300	-5°C to 150°C
C	Nitrile (Butadiene Acrylonitrile)	All sizes	-20°C to 100°C
AA	Natural Rubber	All sizes	-40°C to 90°C

¹ FDA - Food and Drug Administration USP - United States Pharmacopeia

WRAS – Water Regulations Advisory Scheme

KB TYPE – DIAPHRAGM DIMENSIONS

Diaphragm Identification

KB Diaphragms

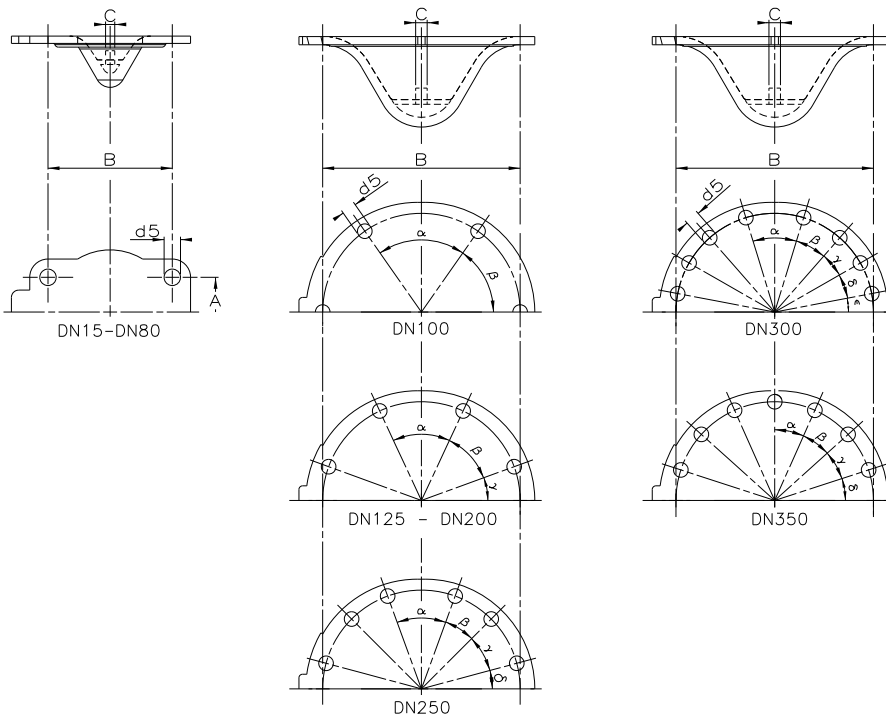

Back Face

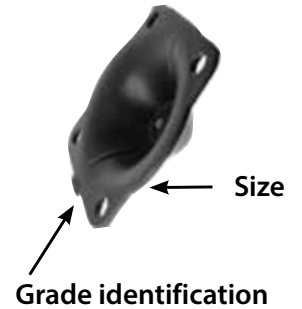

Wetted Face



Size (DN)	Principal Diaphragm Dimensions						Angles From the Holes				
	A	B	C	D (Thickness)	d5	Number of Holes	α	β	γ	δ	ϵ
15	30	54	3/16" BSW	5	7	4	-	-	-	-	-
20	30	54		5	7	4	-	-	-	-	-
25	51	64	1/4" BSW	5	9	4	-	-	-	-	-
32	51	64		5	9	4	-	-	-	-	-
40	51	64		5	9	4	-	-	-	-	-
50	64	89		5	12	4	-	-	-	-	-
65	83	102	5/16" BSW	5.6	7/16"UNC	4	-	-	-	-	-
80	102	137	3/8" BSW	6.4	5/8"UNC	4	-	-	-	-	-
100	-	171		5.5	7/16"UNC	6	70°	55°	-	-	-
125	-	205	7.9	8		8	50°	45°	40°	-	-
150	-	254	5/8" BSW	7.9	1/2"UNC	8	60°	40°	40°	-	-
200	-	305		7.9	5/8"UNC	8	60°	40°	40°	-	-
250	-	381	1" BSW	9.5		5/8"UNC	12	40°	25°	30°	45°
300	-	451		10.3	16		16	34°	24°20'	19°	19°
350	-	527		10.3	7/8"UNC	14	24°	24°	24°	36°	-

BSW = British Standard Whitworth Thread

UNC = Unified Coarse Thread

Note: Dimensions in mm unless otherwise stated

KB TYPE – TOP WORKS

Standard Range

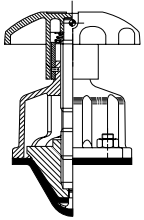

Standard plastic rising handwheel with indicator
DN15 - DN50

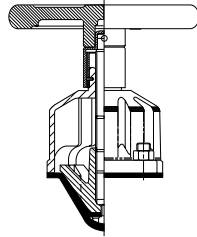

Metal rising handwheel with indicator
DN65 - DN150

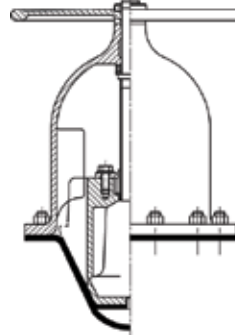

Standard non-rising handwheel without indicator
DN200 - DN350

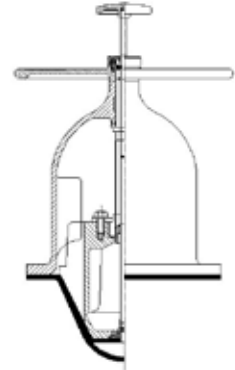

Non-rising handwheel with indicator
DN200 - DN300

High Performance

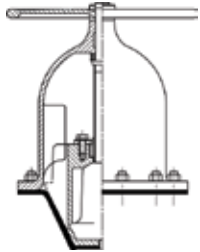

Non-rising handwheel (fluoroelastomer sealed)
DN15 - DN300

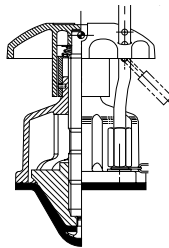

Rising handwheel with indicator (simple padlocking)
DN15 - DN150

KB TYPE – PRESSURE AND TEMPERATURE LIMITS

Maximum manual working pressures for Saunders® KB type diaphragm valves.
For actuated valves, please refer to the appropriate datasheets.

Bonnet pressure limits

		Size (DN)	8	10	15	20	25	32	40	50	65	80	100	125	150	200	250	300	350	
		Handwheel																		
Pressure (bar)	Rising		10	10	10	10	10	10	10	10	10	10	10	10	6	6	-	-	-	-
	Non-rising		-	-	-	-	-	-	-	-	-	-	-	-	-	-	3.5	3.5	3.5	1.5

All Saunders® valves are pressure tested in accordance with BS EN12266-1 standard.

- Shell test: 1.5 times maximum working pressure
- Seat test: 1.1 times maximum working pressure

KB Valve Pressure/Temperature Relationship

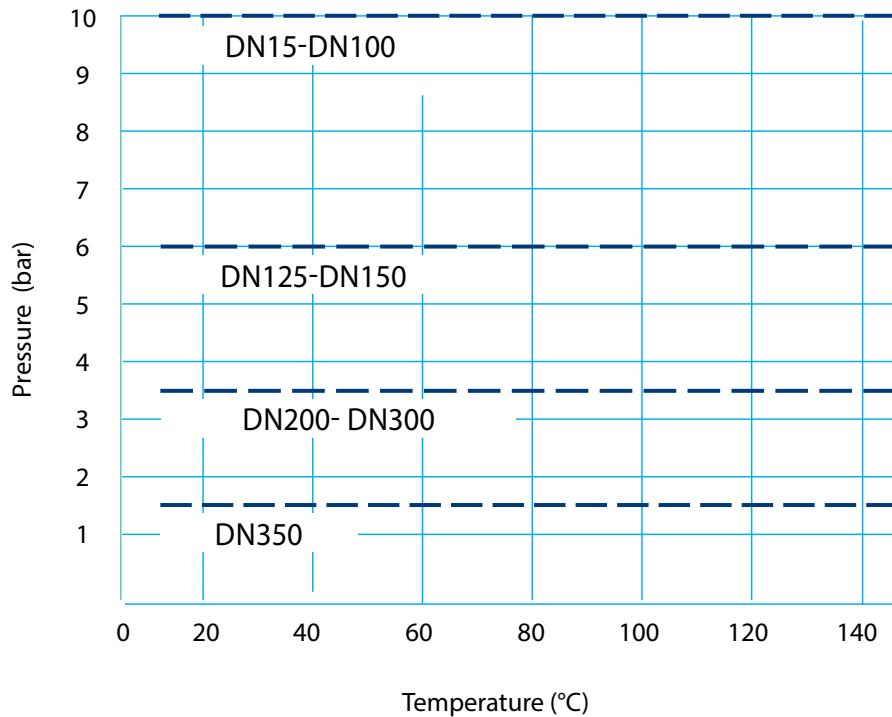

KB TYPE – ASSEMBLED VALVE DIMENSIONS

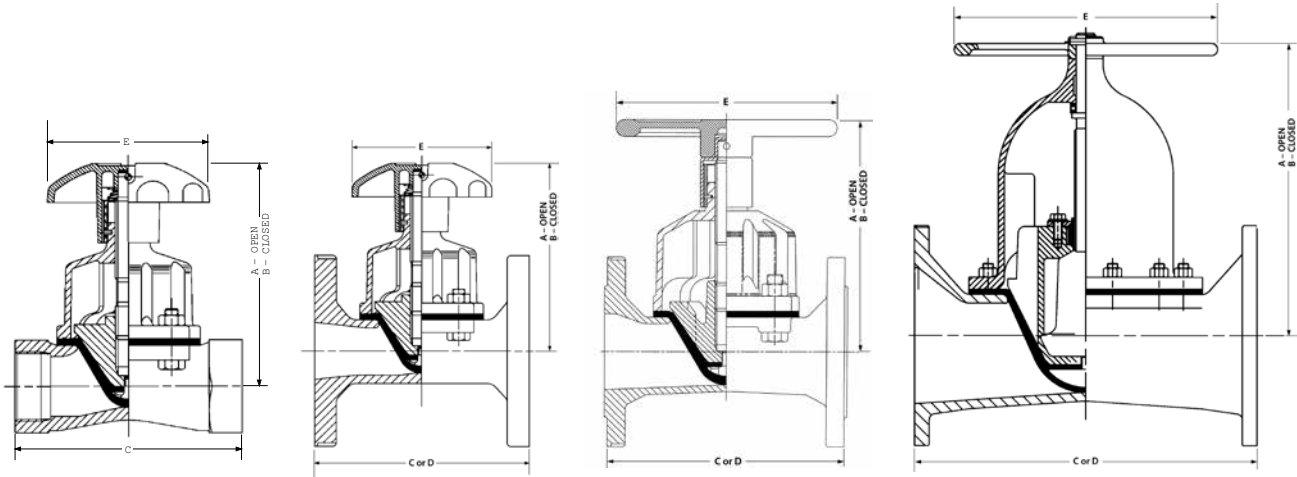

Screwed DN15 – DN50

Flanged DN15 – DN50

Flanged DN65 – DN150

Flanged DN200 – DN350

Size (DN)		15	20	25	32	40	50	65	80	100	125	150	200	250	300	350
Screwed Unlined	A	106	-	166	-	166	182	-	-	-	-	-	-	-	-	-
	B	98	-	159	-	159	162	-	-	-	-	-	-	-	-	-
	C	64	-	111	-	143	168	-	-	-	-	-	-	-	-	-
	Weight	1	-	2	-	3	5	-	-	-	-	-	-	-	-	-
Flanged Unlined	A	105	105	165	165	165	176	234	270	313	335	435	406	557	628	665
	B	97	97	159	159	159	156	210	238	277	293	379	406	557	628	665
	C	108	117	127	146	159	190	216	254	305	356	406	521	635	749	980
	D	130	150	160	180	200	230	290	310	350	400	480	600	730	850	980
	Weight	3	3	5	5	6	11	12	18	32	47	68	109	195	294	462
Flanged Rubber Lined	A	-	-	168	168	168	176	234	270	313	335	435	408	559	630	667
	B	-	-	162	162	162	156	210	238	277	293	379	408	559	630	667
	C	-	-	131	150	163	194	220	258	309	362	412	527	641	755	986
	D	-	-	160	180	200	230	290	310	350	400	480	600	730	850	980
	Weight	-	-	5	5	6	11	12	18	32	47	68	109	195	294	462
Flanged Glass* / Halar Lined	A	106	106	166	166	166	177	235	271	314	336	436	407	558	629	666
	B	98	98	160	160	160	157	211	239	278	294	380	407	558	629	666
	C	110	119	129	148	161	192	218	256	307	358	408	523	637	751	982
	D	130	150	160	180	200	230	290	310	350	400	480	600	730	850	980
	Weight	2	3	5	6	7	11	12	21	34	47	72	118	201	294	462
	E	80	80	120	120	120	120	170	230	280	280	368	368	483	584	699

Note: Dimensions in mm. Weights in kg. Weight may vary with materials, lining and standards. For exact weights please contact Saunders[®]

C valve length = EN 558 Series 7 (ex BS 5156). D valve length = EN 558 Series 1 (ex DIN 3202 Series F1).

* Glass lining is typically available in the size range DN15 - DN150 for KB Type valves. Contact Saunders[®] for further requirements.

KB TYPE – FLOW COEFFICIENTS

DN15						
% Open	Body Material / Lining					
	Cast (Unlined)		Rubber Lined		Glass / Halar	
	Cv	Kv	Cv	Kv	Cv	Kv
100	8.6	7.4	-	-	9.0	7.8
90	8.0	6.9	-	-	8.4	7.3
80	7.3	6.3	-	-	7.7	6.7
70	6.6	5.7	-	-	6.9	6.0
60	6.0	5.2	-	-	6.3	5.4
50	5.2	4.5	-	-	5.4	4.7
40	4.3	3.7	-	-	4.5	3.9
30	3.2	2.8	-	-	3.3	2.9
20	2.1	1.8	-	-	2.2	1.9
10	1.0	0.9	-	-	1.1	1.0
0	0	0	-	-	0	0

DN25						
% Open	Body Material / Lining					
	Cast (Unlined)		Rubber Lined		Glass / Halar	
	Cv	Kv	Cv	Kv	Cv	Kv
100	38	33	31	26	39	34
90	35	30	28	25	36	31
80	32	28	26	23	33	29
70	29	25	24	20	30	26
60	27	23	21	19	27	24
50	23	20	18	16	23	20
40	19	16	15	13	20	17
30	14	12	11	9.8	14	12
20	9.1	7.9	7.3	6.3	9.4	8.1
10	4.5	3.9	3.7	3.2	4.7	4.1
0	0	0	0	0	0	0

DN32						
% Open	Body Material / Lining					
	Cast (Unlined)		Rubber Lined		Glass / Halar	
	Cv	Kv	Cv	Kv	Cv	Kv
100	56	48	46	40	58	50
90	52	45	42	36	54	47
80	48	42	39	34	50	43
70	44	38	36	31	46	40
60	40	35	32	28	42	36
50	34	29	28	24	35	30
40	28	24	23	20	29	25
30	22	19	18	16	23	20
20	16	14	13	11	16	14
10	8.0	6.9	6.0	5.2	8.0	6.9
0	0	0	0	0	0	0

DN40						
% Open	Body Material / Lining					
	Cast (Unlined)		Rubber Lined		Glass / Halar	
	Cv	Kv	Cv	Kv	Cv	Kv
100	75	65	66	57	79	68
90	70	61	61	53	73	63
80	64	55	56	48	67	58
70	58	50	51	44	61	53
60	52	45	46	40	55	48
50	45	39	40	35	47	41
40	38	33	33	29	40	35
30	28	24	24	21	29	25
20	18	16	16	14	19	16
10	9.0	7.8	7.9	6.8	9.5	8.2
0	0	0	0	0	0	0

DN50						
% Open	Body Material / Lining					
	Cast (Unlined)		Rubber Lined		Glass / Halar	
	Cv	Kv	Cv	Kv	Cv	Kv
100	128	111	107	93	138	119
90	119	103	99	86	128	111
80	109	94	91	79	117	101
70	99	86	82	71	106	92
60	90	78	75	65	97	84
50	77	67	64	55	83	72
40	64	55	53	46	69	60
30	47	41	40	35	51	44
20	31	27	26	22	33	29
10	15	13	13	11	17	14
0	0	0	0	0	0	0

DN65						
% Open	Body Material / Lining					
	Cast (Unlined)		Rubber Lined		Glass / Halar	
	Cv	Kv	Cv	Kv	Cv	Kv
100	238	206	195	169	254	220
90	221	191	181	157	236	204
80	202	175	166	144	216	187
70	183	158	150	130	196	170
60	167	145	136	118	178	154
50	143	124	117	101	152	132
40	119	103	97	84	127	110
30	88	76	72	62	94	81
20	57	49	47	40	61	53
10	29	25	23	20	20	17
0	0	0	0	0	0	0

DN80						
% Open	Body Material / Lining					
	Cast (Unlined)		Rubber Lined		Glass / Halar	
	Cv	Kv	Cv	Kv	Cv	Kv
100	330	285	264	228	342	296
90	307	266	246	213	318	275
80	281	243	224	194	291	252
70	254	220	203	176	263	228
60	231	200	185	160	239	207
50	198	171	159	138	205	177
40	165	143	132	114	171	148
30	122	106	98	85	127	110
20	79	68	63	54	82	71
10	40	35	32	28	41	35
0	0	0	0	0	0	0

DN100						
% Open	Body Material / Lining					
	Cast (Unlined)		Rubber Lined		Glass / Halar	
	Cv	Kv	Cv	Kv	Cv	Kv
100	588	509	480	415	618	535
90	547	473	446	386	575	497
80	500	433	408	353	525	454
70	453	392	370	320	476	412
60	412	356	336	291	433	375
50	353	305	288	249	371	321
40	294	254	240	208	309	267
30	218	189	178	154	229	198
20	141	122	115	99	148	128
10	71	61	58	50	74	64
0	0	0	0	0	0	0

DN125						
% Open	Body Material / Lining					
	Cast (Unlined)		Rubber Lined		Glass / Halar	
	Cv	Kv	Cv	Kv	Cv	Kv
100	924	799	720	623	960	830
90	859	743	670	580	893	772
80	785	679	612	529	816	706
70	711	615	554	479	739	639
60	647	560	504	436	672	581
50	555	480	432	374	576	498
40	462	400	360	311	480	415
30	342	296	266	230	355	307
20	222	192	173	150	230	199
10	111	96	86	74	115	99
0	0	0	0	0	0	0

Note: All Kv and Cv values shown here refer to flanged valves. Valves with screwed ends demonstrate different Kv/Cv values. For more information contact Saunders®.

Cv = flow in US gal/min through a valve with ΔP = 1 psi

Kv = flow in m³/hr through a valve with ΔP = 1 bar

1.156 Kv = Cv

KB TYPE – FLOW COEFFICIENTS

DN150							
% Open	Body Material / Lining						
	Cast (Unlined)		Rubber Lined		Glass / Halar ¹		
	Cv	Kv	Cv	Kv	Cv	Kv	
100	1680	1453	1260	1090	1800	1557	
90	1562	1351	1172	1014	1674	1448	
80	1428	1235	1071	926	1530	1324	
70	1294	1119	970	839	1386	1199	
60	1176	1017	882	763	1260	1090	
50	1008	872	756	654	1080	934	
40	840	727	630	545	900	779	
30	622	538	466	403	666	576	
20	403	349	302	261	432	374	
10	202	175	151	131	216	187	
0	0	0	0	0	0	0	

DN200							
% Open	Body Material / Lining						
	Cast (Unlined)		Rubber Lined		Glass / Halar ¹		
	Cv	Kv	Cv	Kv	Cv	Kv	
100	2580	2232	2196	1900	2724	2356	
90	2399	2075	2042	1766	2533	2191	
80	2193	1897	1867	1615	2315	2003	
70	1987	1719	1691	1463	2097	1814	
60	1806	1562	1537	1330	1907	1650	
50	1548	1339	1318	1140	1634	1413	
40	1290	1116	1098	950	1362	1178	
30	955	826	813	703	1008	872	
20	619	535	527	456	653	565	
10	310	268	264	228	327	283	
0	0	0	0	0	0	0	

DN250							
% Open	Body Material / Lining						
	Cast (Unlined)		Rubber Lined		Glass / Halar ¹		
	Cv	Kv	Cv	Kv	Cv	Kv	
100	4020	3478	3420	2958	4296	3716	
90	3739	3234	3181	2752	3995	3456	
80	3417	2956	2907	2515	3652	3159	
70	3095	2677	2633	2278	3308	2862	
60	2814	2434	2394	2071	3007	2601	
50	2412	2087	2052	1775	2578	2230	
40	2010	1739	1710	1479	2148	1858	
30	1487	1286	1265	1094	1590	1375	
20	965	835	821	710	1031	892	
10	482	417	410	355	516	446	
0	0	0	0	0	0	0	

DN300							
% Open	Body Material / Lining						
	Cast (Unlined)		Rubber Lined		Glass / Halar ¹		
	Cv	Kv	Cv	Kv	Cv	Kv	
100	6060	5242	4884	4225	6200	5363	
90	5636	4875	4542	3929	5800	5017	
80	5151	4456	4151	3591	4500	3893	
70	4666	4036	3761	3253	5000	4325	
60	4242	3670	3419	2958	4500	3893	
50	3636	3145	2930	2535	3900	3374	
40	3030	2621	2442	2112	3200	2768	
30	2242	1939	1807	1563	2600	2249	
20	1454	1258	1172	1014	1900	1644	
10	727	629	586	507	1000	865	
0	0	0	0	0	0	0	

DN350							
% Open	Body Material / Lining						
	Cast (Unlined)		Rubber Lined		Glass / Halar ¹		
	Cv	Kv	Cv	Kv	Cv	Kv	
100	10300	8910	9950	8607	-	-	
90	9579	8286	9253	8004	-	-	
80	8755	7574	8457	7316	-	-	
70	7931	6861	7661	6627	-	-	
60	7210	6237	6965	6025	-	-	
50	6180	5346	5970	5164	-	-	
40	5150	4455	4975	4304	-	-	
30	3811	3297	3681	3184	-	-	
20	2472	2138	2388	2066	-	-	
10	1236	1069	1194	1033	-	-	
0	0	0	0	0	-	-	

Cv = flow in US gal/min through a valve of ΔP = 1 psi

Kv = flow in m³/hr through a valve of ΔP = 1 bar

$$1.156 Kv = Cv$$

¹ Glass lining is typically available in the size range DN15 - DN150 for KB Type valves. Contact Saunders® for further requirements.

Note:

The flow coefficient provides a measure of the flow of a valve. It is defined as the volume flow of water at a controlled temperature and a given pressure drop across the valve. This coefficient allows engineers to compare flow capacities of valves of different sizes, types and manufacturers.

WFB TYPE – FEATURES

Saunders® WFB Design

Hand wheel sized for comfortable grip and easy operation

Lubricated for life, and protected from dust, dirt and atmospheric contaminants.

Yellow valve indicator provides visual indication on the position of the valve

Diaphragm replaceable with the valve inline

Compressor provides support to the diaphragm in all positions, improving the life of the diaphragm

Different end connections available

Special diaphragm material designed to withstand temperatures up to 540°C

Reinforced diaphragms give long life and leak free operation

Different screwed combinations available

Saunders® WFB valves provide a reliable solution for fire and marine applications.

With fire you only get one chance!

WFB TYPE-STANDARDS

Saunders® WFB valves are utilised as fire mains hydrants and in tank cleaning services for marine and offshore oil installations. Available in DN40 and DN65 sizes, these are highly specialised valves that have been tested and approved by the world's leading safety agencies, and are designed to work up to a maximum pressure of 15 bar.



“We specified Saunders WFB 65 mm nominal bore fire-mains hydrant valves for our ferries and cruise liners. Significant factors behind this choice are the excellent reliability and the low maintenance costs.”
P&O Cruises (UK) Ltd

Valve Standards

Saunders® WFB valves are manufactured to the following standards:

Flanged	
American	ASME/ANSI B16.24 Class 150 (Gunmetal)
	ASME/ANSI B16.34 Class 150 (SG iron)
British	BS 10 Tables D & E (Gunmetal and SG iron)
British/ European¹	BS EN 1092-2 PN10/16 (SG iron)
	BS EN 1092-3 PN10/16 (Gunmetal)
Japanese	JIS 2239 10K (SG iron)
	JIS 2240 10K (Gunmetal)

¹ Replaces BS 4504 PN10/16

Screwed	
America	NFPA ² 1963 1.5-9 NH (DN40)
	NFPA ² 1963 2.5-7.5 NH (DN65)
British/ European³	BS EN 10226-1 Parallel
	BS EN 10226-2 Taper

² National Fire Protection Association

³ Replaces BS 21 Parallel and Taper



Lloyds Register of Shipping
LR Type Approval Certificate
Certificate No: 97/00047
Model: DN40, DN65



Bureau Veritas
Type Approval Certificate
Certificate No: 2207 3457 C10 H
Model: DN40, DN65



Registro Italiano Navale
Rina
Type Approval
Certificate No: MAC/057/94
Model: DN65



American Bureau of Shipping
List of Type Approved Equipment
Page 25.
Certificate No: 96-WM10305-X
Model No: DN40, DN65

Product Approvals

The whole fire hydrant valve has successfully undergone a high-temperature resistance test (540°C for 20 minutes), BS 5041 Part 1, audited by a Lloyds Surveyor.

WFB TYPE - BODY AND DIAPHRAGM

Body

WFB valves are available in SG iron or gunmetal providing high mechanical strength and resistance to accidental impact. Gunmetal bodies provide superior corrosion resistance, even on highly-demanding applications.

Saunders® provides different WFB valve designs with both female and male end connections for different applications. Additionally, couplings and chains e.g. Morris Instantaneous coupling for the female screwed ends, are available.

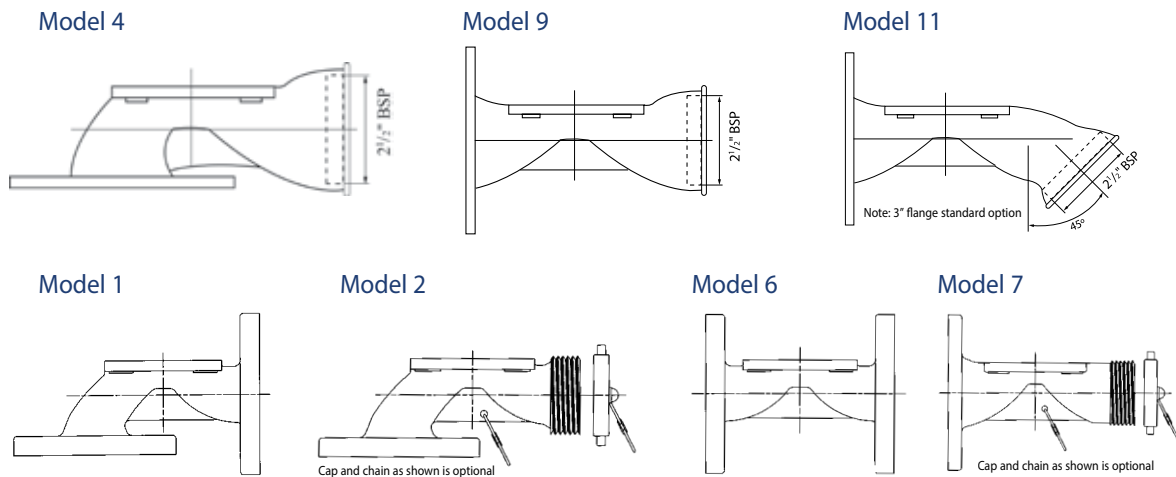

Diaphragm

The diaphragm separates the working parts of the valve from the line media, so there is no chance of internal corrosion of the valve, which is the main cause of fire valve failure.



Diaphragm	Composition	Applications
286	CSM (Chlorosulfonated Polyethylene)	Fire resistant diaphragm specifically designed for fire application valves.
226	FKM (Fluoroelastomer)	This diaphragm (not fire resistant) is a perfect solution for wash decks, with great resistance to lubricating oils and fuel.

Top Works

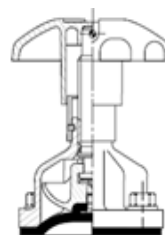

Standard bonnet - Rising handwheel with indicator
All valve sizes

WFB TYPE - FULLY ASSEMBLED VALVE

Body Material Options and Weights

Size (DN)	Models							Body Materials
	1	2	4	6	7	9	11	
40	-	✓	✓	-	✓	✓	-	Gunmetal
65	✓	✓	✓	✓	✓	✓	✓	Gunmetal or SG Iron

Body Materials	Size (DN)	Weight (kg) / Model		
		4	9	11
Gunmetal	40	8.8	8.5	9.8
	65	10.3	10.0	11.5
SG Iron	65	8.4	7.9	9.8



Model 4 with body and bonnet material in SG iron



Model 9 with body and bonnet material in gunmetal



Model 11 with body and bonnet material in gunmetal

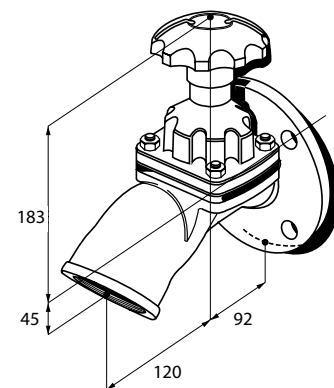
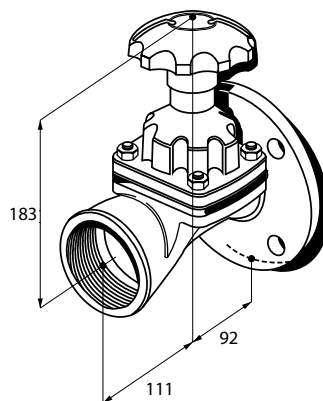
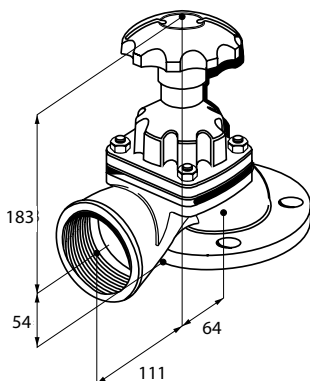

All dimensions are specified in mm.

Pressure testing: Saunders® WFB valves tested in accordance with the BS5041 standard i.e. body strength test to 22.5 bar, seat test to 16.5 bar (1.1 x maximum working pressure).

SPECIAL VERSIONS

Saunders® environmental protective coating has been developed specifically to provide unrivaled corrosive resistance in the industrial processing industry. The green Tefzel™ coating is applied before the injection moulding of PFA or ETFE lining, using an electrostatic powder coating method. By coating the valve body, bonnet and hand wheel, both internal and external corrosive protection is maximized to provide peace of mind in extreme corrosive material processing applications. Available in DN20-DN200 with PFA lining and DN20-DN150 with ETFE lining.

High vacuum duty valves are designed for use down to 10^{-5} Torr. Vacuum grade diaphragms contain extra nylon reinforcement for sizes DN100 and above, as well as a steel stud (not brass) as standard for all sizes. Available for C, 300 & 425 grade diaphragms.

Halar® (ECTFE – ethylene chlorotrifluoroethylene) lining (dark grey) prepared using an electrostatic powder method demonstrates excellent resistance to mineral and oxidising acids, inorganic bases, salts and alcohols, and some resistance to aliphatic and aromatic hydrocarbons. Available in all sizes.

Large “double weir” valves in sizes DN400, DN450 and DN500 are available and consist of two DN300 or DN350 bodies and bonnets (see table below). Please contact Saunders® for more information. Note: these valves are not suitable for use with Group 1 (dangerous) gases.

Size (DN)	A	B	C (Travel)	D
400	750	750	190	700
450	750	750	190	700
500	750	780	230	700

Valve Sizes	
DN400	Fitted with two DN300 bonnets
DN450	Fitted with two DN300 bonnets
DN500	Fitted with two DN350 bonnets

Note: Dimensions in mm

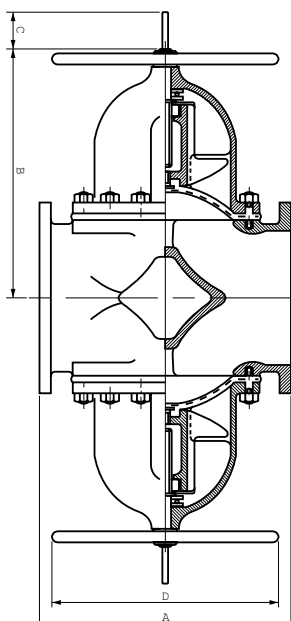

Schematic of large size double weir valves.



Tefzel® coated ETFE lined A type valve

NX CHECK VALVE - FEATURES

Saunders[®] NX Check Valve

Drilled to suit BS 10 Table D,
EN 1092-2 PN10/16 and ASME
B16.1 Class 125

Lining is cost effective to allow
the use of these valves in the
most challenging applications,
avoiding exotic alloys

Instructions on casting
indicate the direction of
the flow

Full bore design minimizes
turbulence, preventing
damage of the pipeline

One way disc design ensures
close at 0.35 bar back
pressure

The disc is manufactured as
one piece, ensuring minimal
maintenance costs

Phosphate and alkyd finish is
applied to the valve to reduce
atmospheric corrosion

**NX is the check valve of choice; a full bore non return
valve capable of handling corrosive media and slurries**

NX CHECK VALVE - ASSEMBLED VALVE DIMENSIONS

A simple one-part disc is the only moving part in the Saunders® NX check valve. This simplicity assists in guaranteeing a long and maintenance-free life in the prevention of reverse flow leakage. The Saunders® NX can be used in vacuum conditions and up to a line pressure of 7 bar. It prevents flow reversal for pressures ≥ 0.35 bar, ensuring 100 % shut off with repeated reliability.

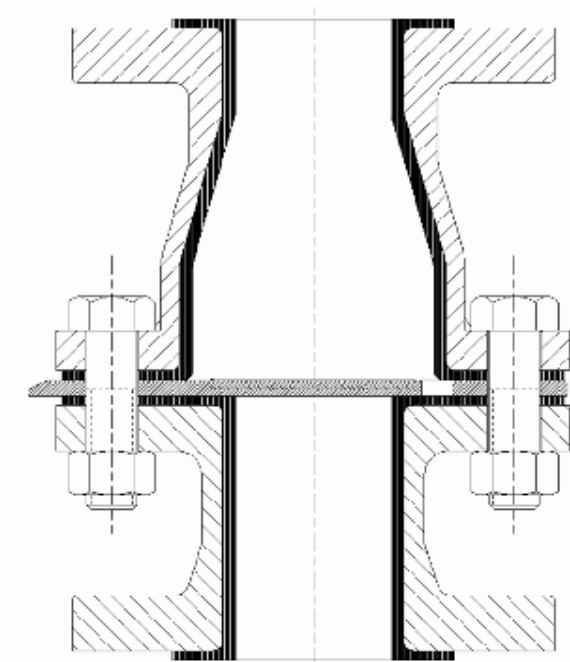

Body

- Cast iron
- SG iron hard rubber lined

Disc

- Rubber coated steel

Seat

- Cast iron
- SG iron hard rubber lined

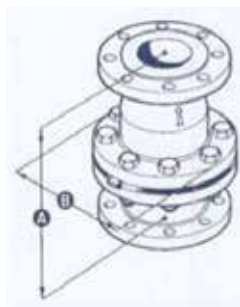

Size (DN)	A - Overall Length (mm)		B - Overall Diameter (mm)
	Cast Iron	Rubber	All Specifications
25	150	157	124
40	180	186	149
50	200	204	162
80	260	265	216
100	350	356	295
150	400	406	327

For other rubber lining material options, please contact Saunders®.

Standards
BS EN 12334 — Design standard
BS 10 Table D — Flanged body ends
EN 1092-2 PN10/16 — Flanged body ends
ASME B16.1 Class 125 — Flanged body ends

NX CHECK VALVE - DISC TYPE & FLOW COEFFICIENTS

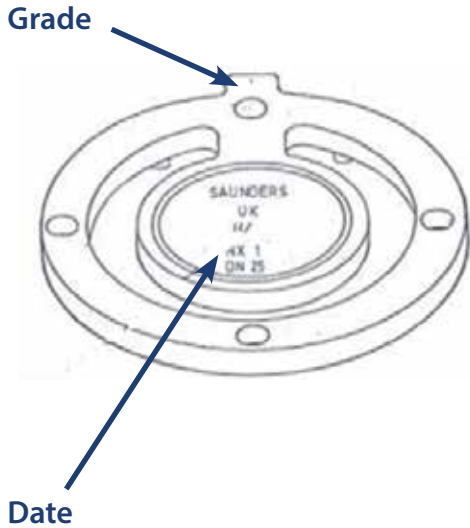

Disc	Composition	Applications	Temperature
226	FKM (Fluoroelastomer)	Sulfur cured. Specially recommended for applications involving gases at high temperature, concentrated acids, aromatic solvents, low concentrated chlorine solutions, ozone and unleaded petroleum.	-5°C to 150°C
300	Butyl (Isobutylene isoprene)	Sulphur cured with carbon black reinforcement. It is a great solution for diluted acids and alkalis, drinking water and abrasive applications like phosphoric acid in low concentration.	-30°C to 100°C

Weights with reference to HRL model

Size (DN)	Weight (kg)
25	4
40	6.8
50	8.6
80	15
100	30
150	50

Flow coefficients

Body material/ lining	Cast Iron unlined		SG Iron rubber lining	
	Size (DN)	Cv	Kv	Cv
25	28	24	25	22
40	79	68	71	61
50	135	117	121	105
80	285	247	256	221
100	486	420	437	378
150	811	702	729	631

Cv = flow in US gal/min through a valve at $\Delta P = 1$ psi

Kv = flow in m³/hr through a valve at $\Delta P = 1$ bar

$$1.156 \text{ Kv} = \text{Cv}$$

Note: The flow coefficient provides a measure of the flow of a valve. It is defined as the volume flow of water at a controlled temperature and a given pressure drop across the valve. This coefficient allows engineers to compare flow capacities of valves of different sizes, types and manufacturers.



ACTUATION - ES MODULAR DESIGN

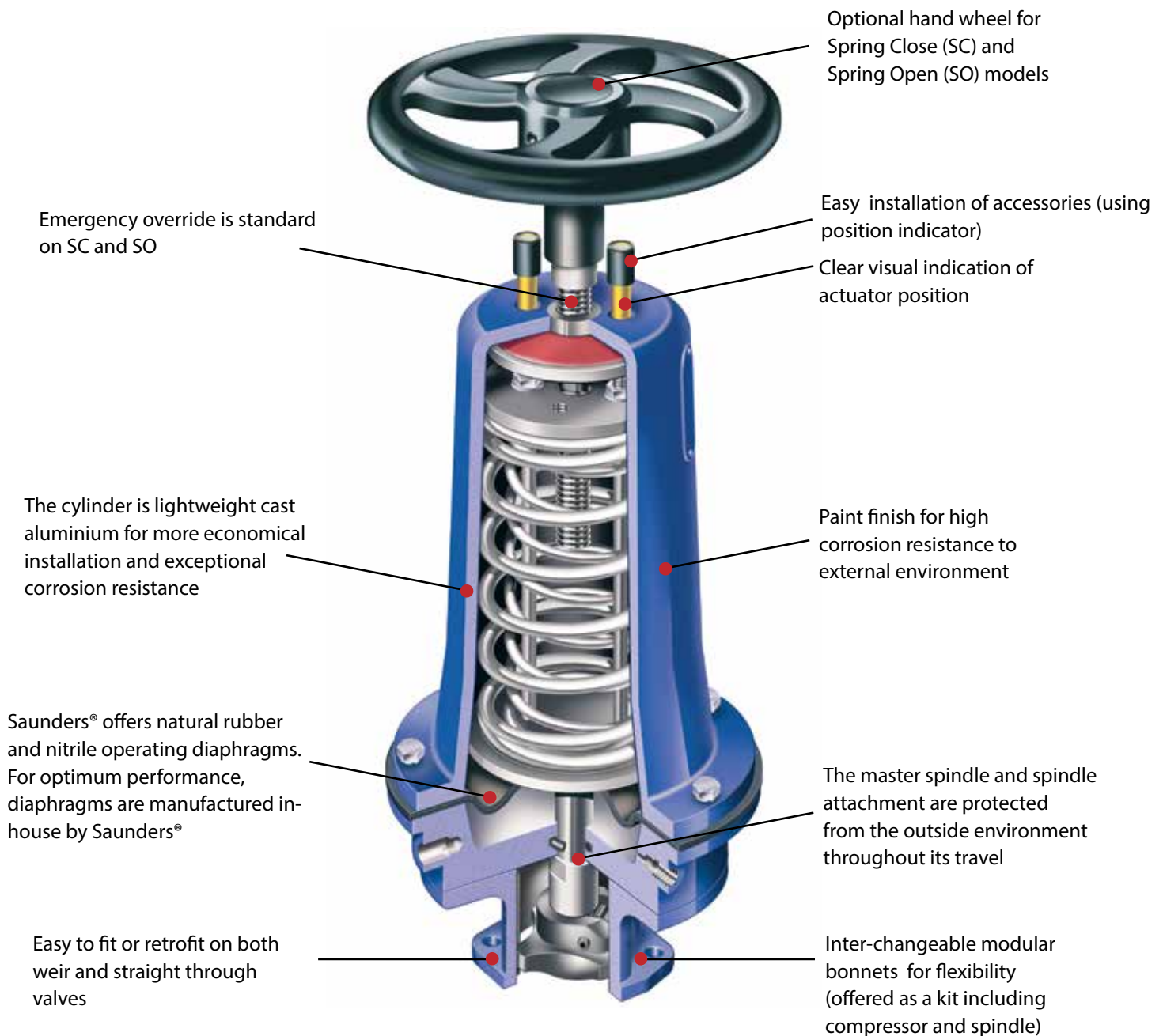

Wide range of actuators that provide reliable remote control

ACTUATION - MODEL RANGE AND MODES OF OPERATION

When manual operation is inadequate or inconvenient, Saunders® offer a variety of actuators covering valve sizes up to DN250 (10"), for different line and operating pressure options. We offer three different actuators, designed for various characteristic performances.

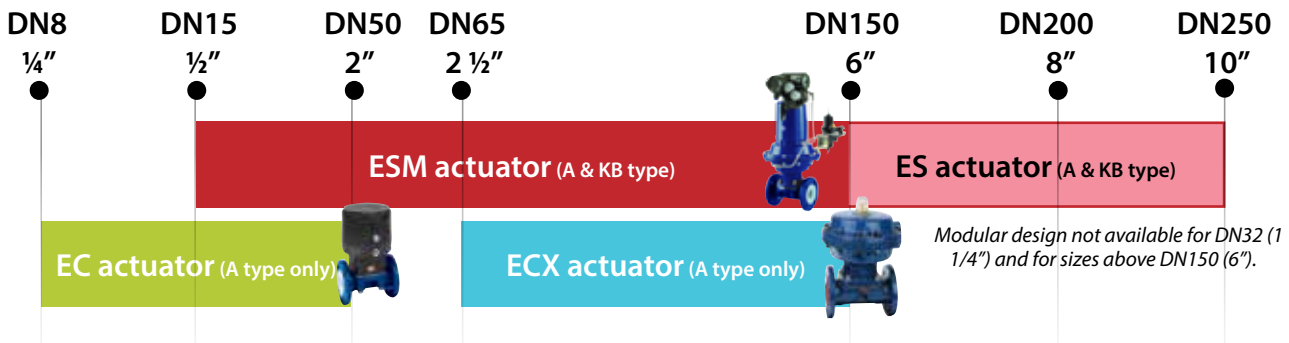

EC	ECX	ES Modular
<ol style="list-style-type: none"> 1 Compact piston style actuator 2 Spring packs to suit pressure requirements 3 Polyethersulfone (PES) bonnet 4 Versatile and robust design 5 Temperature range of -10 ° to 100 °C ambient (autoclave maximum 150 °C) 	<ol style="list-style-type: none"> 1 Diaphragm operated actuator, a compact extension to the EC size range 2 Comprehensive spring packs for a wide range of pressures 3 Full range of accessories 4 Light weight silicon aluminium housings 5 Durable paint coating for environmental protection 	<ol style="list-style-type: none"> 1 Diaphragm operated actuator, modular design for flexibility 2 Adjustable spring tension to optimize closure force and maximize diaphragm life 3 Full range of accessories 4 Light weight silicon aluminium housings 5 Durable paint coating for environmental protection

	Spring Close (SC)	Spring Open (SO)	Double Acting (DA)
Mode of operation	Closes the valve against line pressure in the event of failure (or intended shutoff) of operating pressure to the actuator.	Opens the valve to allow line fluid to flow in the event of failure (or intended shutoff) of operating pressure to the actuator.	Operating pressure opens and closes the valve. Requires a lock up valve to retain the position preceding the failure.
Normal use	When valve is usually in the closed position (to avoid using a constant supply of operating pressure).	When valve is usually in the open position (to avoid using a constant supply of operating pressure).	When a failsafe mode is not required.

SIZING YOUR ACTUATOR

To be able to properly size the actuators you will need the following information:

- 1 **Valve Type** A or KB type
- 2 **Diaphragm Type** Rubber or PTFE diaphragm
- 3 **Actuator Type** EC, ECX, or ES
- 4 **Valve Size** Typically the same size as the pipe system
- 5 **Line Pressure** Pressure in the *pipeline* that the actuator needs to close
- 6 **Operating Pressure** Pressure available in the system to *operate* the valve
- 7 **Pressure Drop** As represented in figure below, there are two extreme options (0 % or 100 % pressure drop)

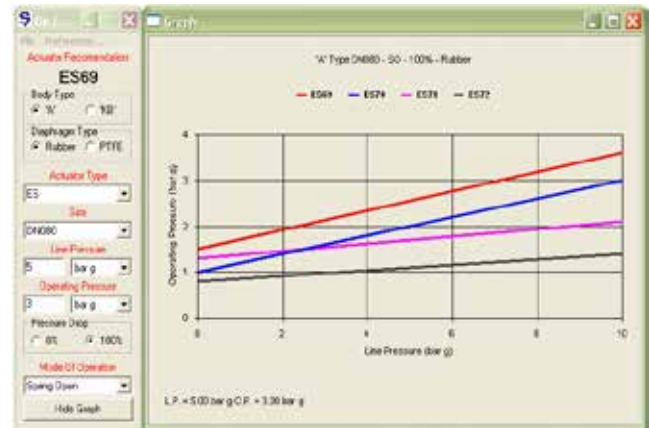

Saunders[®] On/Off Actuation Selection Software

To use this software, you simply enter your process data into the selection boxes. The program then sizes the actuator to suit your specific requirements.

- 8 **Actuator Mode** Spring Close, Spring Open, Double Acting
- 9 **Accessories** Solenoid valves, switchboxes, positioners, limit stops, etc

100 % Pressure Drop

The line pressure is on one side of the weir only. This is the most common service condition.

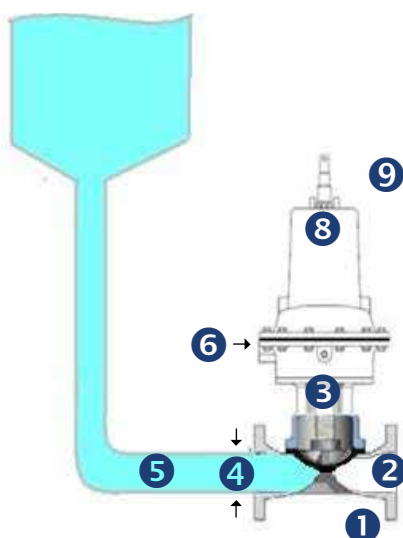

0 % Pressure Drop

The line pressure is on both sides of the weir. Maximum force is working against the actuator.

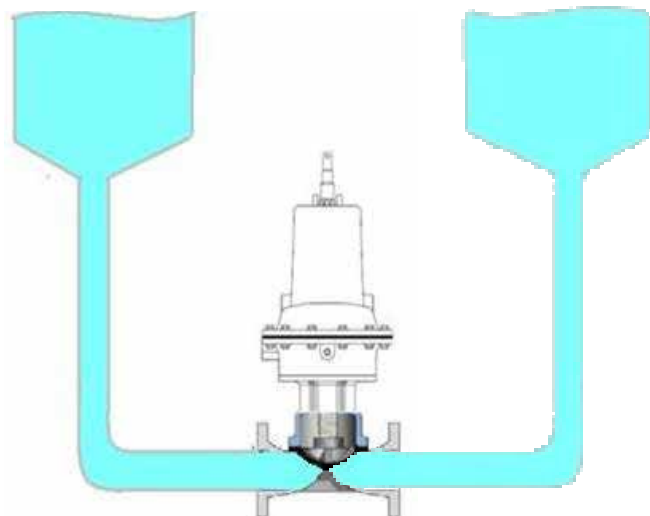

ESM/ES ACTUATORS

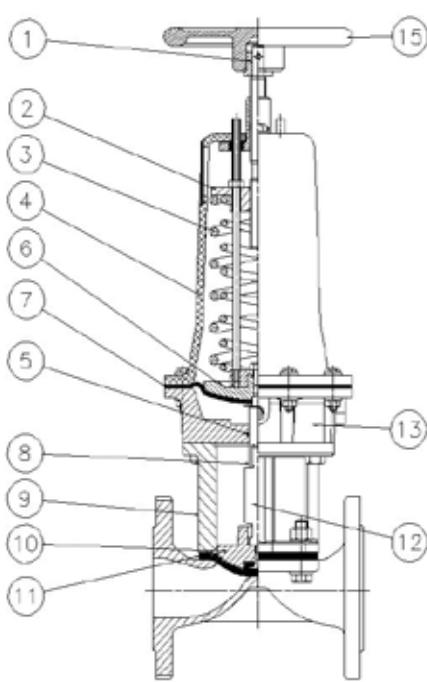

Spring Close

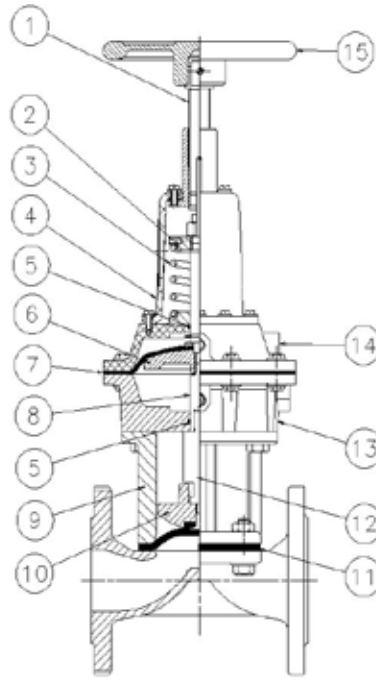

Spring Open

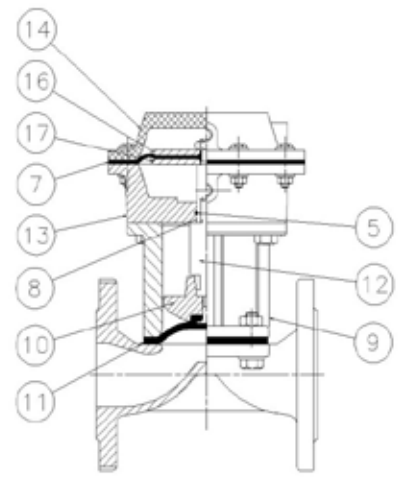

Double Acting

Item	Component	Material		
		Spring Close	Spring Open	Double Acting
1	Handwheel spindle	Mild steel		-
2	Upper spring plate	Mild steel		-
3	Spring	Steel		-
4	Cover	Silicon aluminium		-
5	Cylinder "O"ring	Nitrile		-
6	Diaphragm plate	SG Iron		-
7	Operating diaphragm	Rubber		
8	Master spindle	Stainless steel		
9	Bonnet	Cast Iron		
10	Compressor	Cast Iron		
11	Line diaphragm	Rubber or PTFE		
12	Spindle attachment	Stainless steel		
13	Lower cylinder	Silicon aluminium		
14	Upper cylinder	Silicon aluminium		
15	Handwheel	Cast Iron		
16	Upper diaphragm plate	-	-	Mild steel
17	Lower diaphragm plate	-	-	Mild steel

ESM/ES ACTUATORS

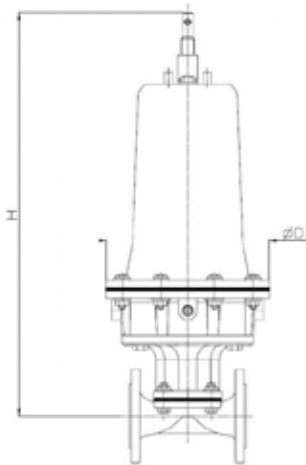

ESM (SC)

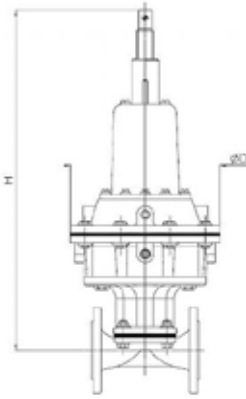

ESM (SO)

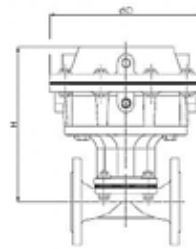

ESM (DA)

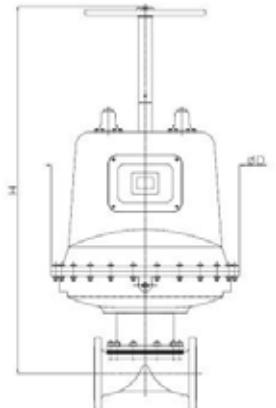

ES66

The table below shows the diameter/width and the maximum height of the actuator from the centre of the valve flange or pipeline.

Note: Dimensions are based on unlined bodies and bare shaft actuators. Add-on handwheel dimensions are displayed in the adjacent table.

Actuator Model	Add-on
68/69/70	+14mm
61/62/63	+14mm
71/64	+18mm

For all ES (non-modular) actuators, dimensions include handwheel add-on as it is provided as standard.



Dimensions

	Actuator Model	H (mm) – A type valves													H (mm) – KB type valves												
		D (mm)	DN 15	DN 20	DN 25	DN 32	DN 40	DN 50	DN 65	DN 80	DN 100	DN 125	DN 150	DN 200	DN 250	DN 25	DN 32	DN 40	DN 50	DN 65	DN 80	DN 100	DN 125	DN 150	DN 200		
Spring Close	ESM61	169	408	413	423	390	435	462	-	-	-	-	-	-	-	480	480	480	-	-	-	-	-	-	-	-	-
	ESM62	260	-	-	463	451	476	503	502	504	-	-	-	-	-	517	517	517	522	546	-	-	-	-	-	-	
	ESM63	316	-	-	-	-	-	721	732	735	759	-	-	-	-	-	-	744	764	791	820	-	-	-	-	-	
	ESM64	425	-	-	-	-	-	-	-	788	809	828	899	-	-	-	-	-	-	-	844	870	878	947	-	-	
	ESM65	549	-	-	-	-	-	-	-	-	1012	1040	1106	-	-	-	-	-	-	-	-	1176	1089	1155	-	-	
	ES66	750	-	-	-	-	-	-	-	-	-	-	-	1459	1529	1589	-	-	-	-	-	-	-	1511	1529		
Spring Open	ESM68	169	382	377	389	351	401	428	-	-	-	-	-	-	522	522	522	-	-	-	-	-	-	-	-	-	
	ESM69	260	-	-	497	401	511	537	536	538	-	-	-	-	555	555	555	560	581	-	-	-	-	-	-		
	ESM70	316	-	-	-	-	-	773	783	786	810	-	-	-	-	-	795	814	841	859	-	-	-	-	-		
	ESM71	425	-	-	-	-	-	-	-	783	822	878	-	-	-	-	-	-	-	834	858	838	-	-	-		
	ESM72	549	-	-	-	-	-	-	-	879	907	974	-	-	-	-	-	-	-	-	955	935	1034	-	-		
	ES73	750	-	-	-	-	-	-	-	-	-	-	978	1236	1245	-	-	-	-	-	-	-	-	1337	1264		
Double Acting	ESM54	260	156	162	171	130	183	208	-	-	-	-	-	-	228	228	228	-	-	-	-	-	-	-	-	-	
	ESM55	316	-	-	222	190	235	261	261	262	-	-	-	-	279	279	279	284	305	-	-	-	-	-	-		
	ESM56	425	-	-	-	-	-	306	313	315	339	-	-	-	-	-	-	331	350	381	406	-	-	-	-		
	ESM57	549	-	-	-	-	-	-	-	357	385	451	-	-	-	-	-	-	-	396	421	401	500	-	-		
	ESM58	650	-	-	-	-	-	-	-	383	411	477	-	-	-	-	-	-	-	-	447	427	526	-	-		

Existing ES actuator only ¹ PTFE diaphragm not available - rubber diaphragm only

D = Actuator diameter/width H = Actuator height

ESM/ES ACTUATORS

Head Volumes

Model	Head Volume (cm ³)												
	DN15	DN20	DN25	DN32	DN40	DN50	DN65	DN80	DN100	DN125	DN150	DN200	DN250
ESM 54/61/68	147	164	196	230 ¹	260	328	-	-	-	-	-	-	-
ESM 55/62/69	-	-	1150	1360 ¹	1425	1490	1575	1670	-	-	-	-	-
ESM 56/63/70	-	-	-	-	-	2890	3050	3245	3440	-	-	-	-
ESM 57/64/71	-	-	-	-	-	-	-	6640	6965	7440	7835	-	-
ESM 58/65/72	-	-	-	-	-	-	-	-	11470	11470	14915	-	-
ES 66/73	-	-	-	-	-	-	-	-	-	-	-	49170	49170

Weights

Assembled weight (kg) – Head, bonnet, attachment and compressor

	Model	A type valves													KB type valves											
		DN 15	DN 20	DN 25	DN 32	DN 40	DN 50	DN 65	DN 80	DN 100	DN 125	DN 150	DN 200	DN 250	DN 25	DN 32	DN 40	DN 50	DN 65	DN 80	DN 100	DN 125	DN 150	DN 200		
Spring Close	ESM61	7.1	7.1	7.5	8	8	8.9	-	-	-	-	-	-	-	8.6	8.6	8.6	-	-	-	-	-	-	-	-	-
	ESM62	-	-	17	19	18	19	20	21 ¹	-	-	-	-	-	19	19	19	20	20	-	-	-	-	-	-	-
	ESM63	-	-	-	-	-	34	34	36	37 ¹	-	-	-	-	-	-	-	34	35	37	40	-	-	-	-	-
	ESM64	-	-	-	-	-	-	-	74	76	80	89	-	-	-	-	-	-	-	77	78	83	92	-	-	-
	ESM65	-	-	-	-	-	-	-	-	122	126	135	-	-	-	-	-	-	-	-	-	123	128	137	-	-
	ES66	-	-	-	-	-	-	-	-	-	-	345	390	440	-	-	-	-	-	-	-	-	-	350	395	-
Spring Open	ESM68	5.6	5.8	5.9	7.0	6.5	7.3	-	-	-	-	-	-	-	7.1	7.1	7.1	-	-	-	-	-	-	-	-	-
	ESM69	-	-	14	13	14	15	16	17	-	-	-	-	-	15	15	15	16	17	-	-	-	-	-	-	-
	ESM70	-	-	-	-	-	27	28	29	31	-	-	-	-	-	-	-	28	28	30	33	-	-	-	-	-
	ESM71	-	-	-	-	-	-	-	-	54	58	67	-	-	-	-	-	-	-	56	56	61	-	-	-	-
	ESM72	-	-	-	-	-	-	-	-	74	78	87	-	-	-	-	-	-	-	-	-	76	81	90	-	-
	ES73	-	-	-	-	-	-	-	-	-	-	-	345	390	-	-	-	-	-	-	-	-	-	-	350	-
Double Acting	ESM54	4.2	4.4	4.5	5.3	5.0	5.9	-	-	-	-	-	-	-	8.6	8.6	8.6	-	-	-	-	-	-	-	-	-
	ESM55	-	-	11	9.4	12	13	14	15	-	-	-	-	-	15	15	15	16	17	-	-	-	-	-	-	-
	ESM56	-	-	-	-	-	21	22	23	25	-	-	-	-	-	-	-	22	23	25	27	-	-	-	-	-
	ESM57	-	-	-	-	-	-	-	-	49	53	62	-	-	-	-	-	-	-	50	50	56	65	-	-	-
	ESM58	-	-	-	-	-	-	-	-	72	76	85	-	-	-	-	-	-	-	-	-	73	79	88	-	-

Existing ES actuator only

¹ PTFE diaphragm not available - rubber diaphragm only

Operating Diaphragm (catalogue code)	Natural rubber (Q grade)	ES 53/60/67 ²	ESM 54/61/68	ESM 55/62/69	ESM 56/63/70	ESM 57/64/71	ESM 58/65/72	ES 66/73
		Nitrile rubber (C grade)	VS00867RD1	VS01568RD1	VS04069RD1	VS06570RD1	VS08071RD1	VS12572RD1
		VS00867RD2	VS01568RD2	VS04069RD2	VS06570RD2	VS08071RD2	VS12572RD2	VS20073RD2

² Obsolete models (codes provided for replacement spares purposes only)

EC ACTUATORS

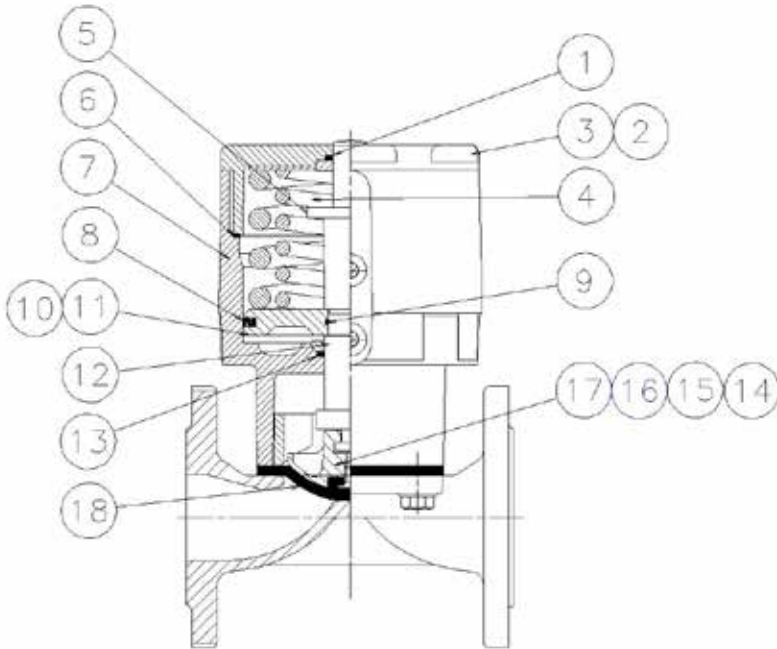

Spring Close

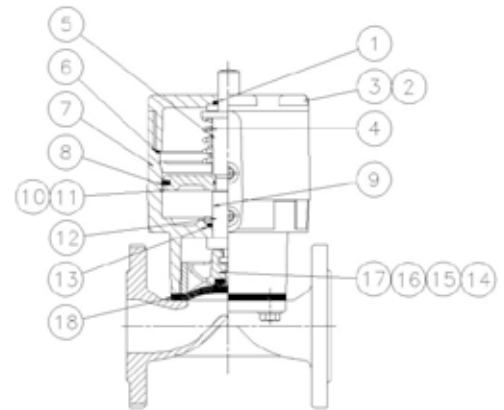

Spring Open

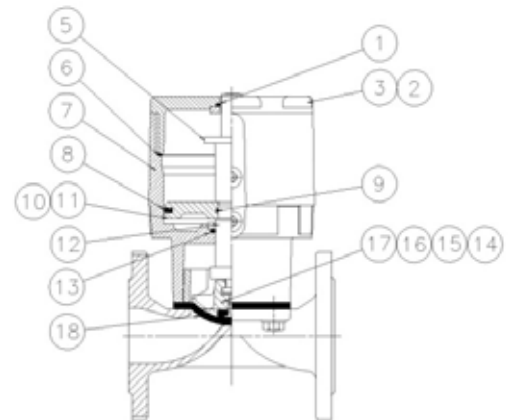

Double Acting

Item	Component	Material			Size Range (DN)
		Spring Close	Spring Open	Double Acting	
1	Indicator seal		Viton		—
2	Cap		IXEF		40 — 50
3	Cap		PES		8 — 25
4	Spring	Steel		—	—
5	Indicator		IXEF		—
6	Bonnet/cap o-ring		Nitrile		—
7	Bonnet		PES		—
8	Piston outer seal		Viton		—
9	Piston inner seal		Nitrile		—
10	Piston		IXEF		40 — 50
11	Piston		PES		8 — 25
12	Spindle		PES		—
13	Spindle seal		Viton		—
14	Compressor		Silicon aluminium		15 — 50
15			Silicon aluminium		40 — 50
16			Mild steel		15 — 25
17			Mazak		8 — 10
18	Line diaphragm		Rubber or PTFE		—

EC ACTUATORS

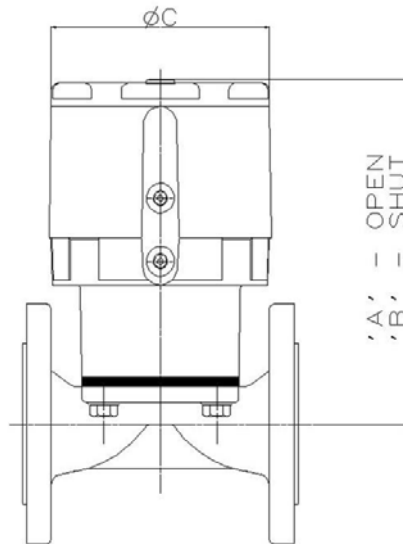

- A - Actuator height (open)
- B - Actuator height (closed)
- C - Actuator diameter/Width

All dimensions are based on unlined bodies.

The table below shows the diameter/width and maximum height of the actuator from the centre of the valve flange or pipeline.

Dimensions & Volumes

		Dimensions (mm)					
		DN8	DN15	DN20	DN25	DN40	DN50
Spring Open, Spring Close, Double Acting	A	112	127	160	161	224	240
	B	110	122	152	154	210	220
	C	58	70	103	103	153	153
Upper Head Volume (cm³)	(to Close)	22	49	212	212	988	995
Lower Head Volume (cm³)	(to Open)	8	16	62	62	244	336

Weights

		Weight (kg)					
		DN8	DN15	DN20	DN25	DN40	DN50
Spring Close, Spring Open, Double Acting		0.29	0.5	1.4	1.5	4	4.9
		0.25	0.46	1.1	1.3	2.9	3.2
		0.24	0.45	1	1.2	2.7	3

Air Connections

All EC actuator air inlet parts are 1/8" BSP or 1/8" NPT

ECX ACTUATORS

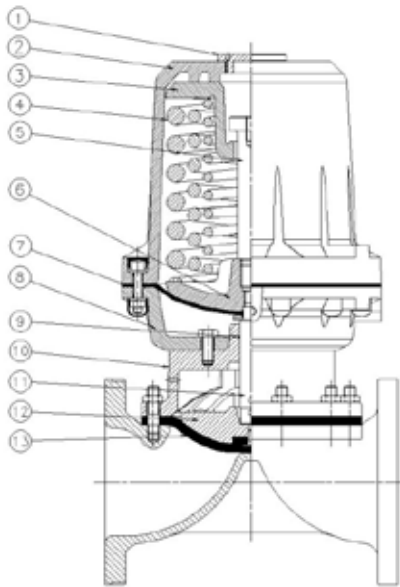

Spring Close

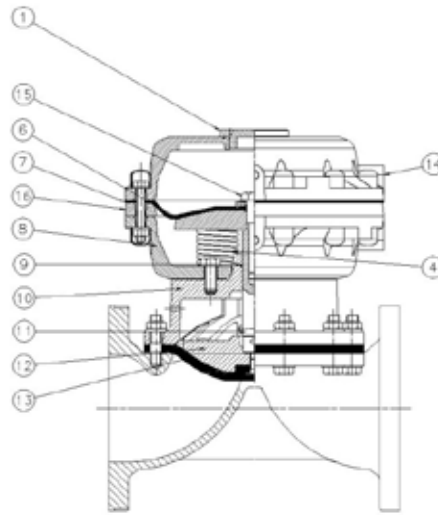

Spring Open

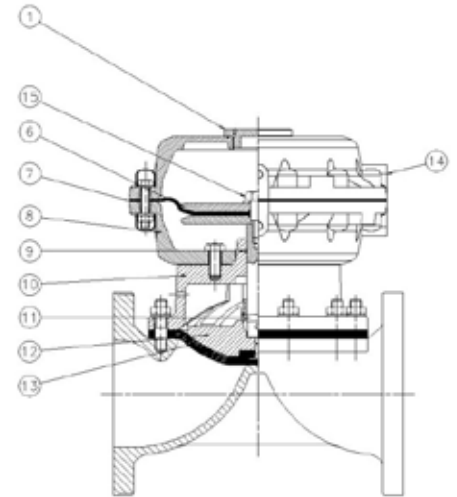

Double Acting

Item	Component	Material		
		Spring Close	Spring Open	Double Acting
1	Cover plug		Mild steel	
2	Cover	Aluminium alloy	—	—
3	Upper spring plate	SG Iron	—	—
4	Spring		Steel	
5	Spring retaining bolt	Mild steel	—	—
6	Diaphragm plate		Forged steel	
7	Operating diaphragm		Rubber	
8	Lower cylinder		Silicon aluminium	
9	Bonnet o-ring		Rubber	
10	Bonnet		SG Iron	
11	Spindle		Stainless steel	
12	Compressor		SG Iron	
13	Line diaphragm		Rubber or PTFE	
14	Upper cylinder	—	Silicon aluminium	
15	Spindle screw	—	Steel	
16	Spacer ring	—	Silicon aluminium	—

Visual Indicator		
Item	Component	Material
17	Indicator cover	Polycarbonate
18	Indicator	Polypropylene

Note: The visual indicator is an optional extra on the ECX

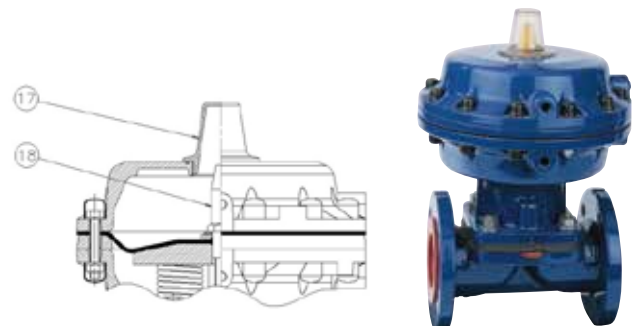

ECX ACTUATORS

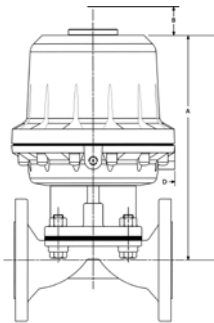

ECX (SC)

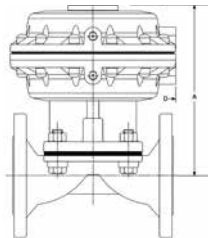

ECX (SO and DA)

There are seven models in the ECX range, split into three modes of operation: Spring Close (SC), Spring Open (SO) and Double Acting (DA).

For all the SC versions, five different spring packs are available (eg. F1 to F5). The number denotes the strength of the spring pack, 1 being the weakest and 5 the strongest.

H - Actuator Height

D - Actuator Diameter/Width

The following table shows the maximum height and the diameter of the actuator from the centre of the valve flange or pipeline.

Dimensions & Volume

	Model	H - Height (mm)					D - Diameter (mm)					Head Volume (cm ³)
		DN65	DN80	DN100	DN125	DN150	DN65	DN80	DN100	DN125	DN150	
Spring Close	Models F	363	380	419	-	-	266	266	266	-	-	1940
	Models G	411	427	467	-	-	266	266	266	-	-	1940
	Models H	-	-	573	586	591	-	-	360	360	360	4320
Spring Open	Models S	252	268	308	-	-	266	266	266	-	-	2100
	Models H	-	-	353	369	371	-	-	360	360	360	5620
Double Acting	Models S	252	268	308	-	-	266	266	266	-	-	2,125 (Open) 2,410 (Close)
	Models H	-	-	353	369	371	-	-	360	360	360	5,340 (Open) 5,200 (Close)

	Model	Weight (kg)				
		DN65	DN80	DN100	DN125	DN150
Spring Close	Models F1-F3	21.8 - 29.1	27.2 - 31.8	32.9 - 35.5	—	—
	Models G1-G3	23.5 - 35.0	26.2 - 37.7	33.9 - 41.4	—	—
	Models H1-H3	—	—	51.8 - 69.0	54.8 - 72.0	74.7 - 87.0
Spring Open	Models S	12.7	16.3	20.0	—	—
	Models H	—	—	36.8	40.3	48.8
Double Acting	Models S	12.7	15.5	19.5	—	—
	Models H	—	—	34.3	37.8	46.0

Air Connections and Operating Diaphragms

Operating diaphragm (catalogue code)		Models F, G and S	Model H
		Natural rubber (Q grade)	VS04069RD1
Nitrile rubber (C grade)		VS04069RD2	VX150HxRD2
Air connections (air inlet ports)		1/4" BSP	

All dimensions are based on unlined bodies.



ACTUATION ACCESSORIES

Accessories								
Model	Size Range	Valve type	Material	Solenoid	Switchbox	Positioner	Air Filter	Handwheel
ES	DN15-DN250	A, KB	SiAl ⁽¹⁾	✓	✓	✓	✓	✓
EC	DN8-DN50	A	PES ⁽²⁾	✓	✓	✓	✗	✗
ECX	DN65-DN150	A	SiAl ⁽¹⁾	✓	✓	✗	✓	✗

⁽¹⁾ SiAl – Silicon-Aluminium

⁽²⁾ PES – Polyethersulfone

✓ Available

✗ Unavailable



007 Switchbox

Modular switch-boxes are available for the ES Modular actuator range.

Offering a wide range of both mechanical and proximity switches as well as other options, i.e. ASi-interface.



Shown mounted to ESM Actuator

ES Positioner

Provides precise control of the flow through the valve. This long life corrosion resistant range suits a wide variety of applications with reliability and accuracy. Available as pneumatic, electro-pneumatic, intrinsically safe and explosion proof, together with a variety of feedback options. A digital option is also available.



Opti-SET

Economical, compact and lightweight switchbox suitable for the EC actuator. Self setting, which minimizes validation/set-up-time, it is available with mechanical or proximity switches including an intrinsically safe option.



Mini Positioner

For control application using an EC actuated valve, Saunders® offers pneumatic, electropneumatic and digital inputs with sensor feedback option and linear mounting design providing a compact control solution.



Saunders® I-VUE

The Saunders® I-VUE is a compact intelligent valve sensor that provides accurate and reliable valve position feedback. It is suitable for EC or ECX actuated valves. Key Features and Benefits:

- Available as Point-to-Point or with network capabilities (ASi and DeviceNet)
- Highly accurate electronic sensing technology to continuously monitor valve position.
- Self Setting (without entry) feature that facilitates setting and programming of switch without opening the enclosure.



MODULE Switchbox

This module switchbox option is available for EC and ECX actuator ranges. The switchbox offers a wide range of mechanical and proximity sensors with space for up to 4 switches, integral solenoid valve and ASi interface (which can be retrofitted).



Solenoid valves

A wide range of locally mounted banjo solenoid valves can be fitted to the Saunders® actuator range with a manual override position and various hazardous area classifications. The solenoid range is designed to cover all requirements.

Other control options available upon request. Please, contact Saunders® for more information

CATALOGUE CODES

A & KB Type Valves

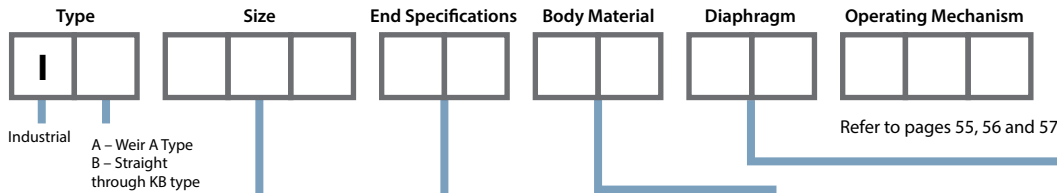

Size		BS156 Length Flanged		Cast Iron		SG Iron		PTFE	
DN8	008	BS10 Table D	F1	Rubber Diaphragm	CX	Rubber Diaphragm	ZX	214/300	P1
DN10	010	BS4504 PN10	F3	PTFE Diaphragm	CW	PTFE Diaphragm	ZW	214/425	P2
DN15	015	ANSI 125/150	F4	Butyl Lined	CB	Butyl Lined	ZB	214/226	P3
DN20	020	JIS 10K	F5	Hard Rubber Lined (HRL)	CC	Hard Rubber Lined (HRL)	ZC	214K/425	P7
DN25	025	PN10 4-Bolt	F6	HRL for PTFE	CD	HRL for PTFE	ZD	214S/425	S5
DN32	032	Screwed Female		HRL Full Face	CJ	HRL Full Face	ZJ	Fluoroelastomer	
DN40	040	BS21 Rp	S1	HRL Full Face for PTFE	CK	HRL Full Face for PTFE	ZK	226	V1
DN50	050	BS21 Rc	S2	Soft Rubber Lined	CS	Soft Rubber Lined	ZS	Natural Rubber	
DN65	065	API/NPT	S3	Neoprene Lined	CN	Neoprene Lined	ZN	AA	A1
DN80	080	DIN Length Flanged		Glass Lined	CG	ETFE Lined	ZE	Q	A2
DN100	100	DIN ND10	D1	Cast Steel		PFA Lined	ZF	Butyl	
DN125	125	DIN ND10-4 Bolt	D2	Rubber Diaphragm	QX	PP Lined	ZP	300	B1
DN150	150	US Length Flanged		PTFE Diaphragm	QW	PVDF Lined	ZV	300 vac	B2
DN200	200	ANSI 125/150	U1	Hard Rubber Lined (HRL)	QC	Galvanised	ZZ	Nitrile	
DN250	250			HRL for PTFE	QD	Gunmetal		C	C1
DN300	300			Stainless Steel		Rubber Diaphragm	GX	C vac	C2
DN350	350			Rubber Diaphragm	SX	PTFE Diaphragm	GW	XA	XA
				PTFE Diaphragm	SW			EPDM	
								425	E2
								425 vac	E6
								CSM (formerly Hypalon)	
								237	H1
								286 fire	H3
								Neoprene	
								HT	N1

WFB Type Valve

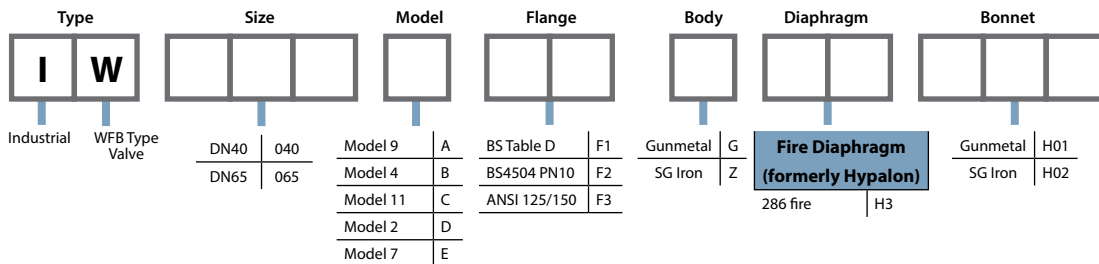

CATALOGUE CODES

Sub Assembly Manual Bonnets Only

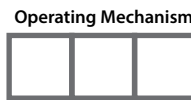
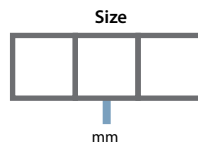
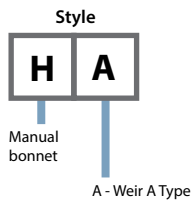

Spares Kits	
Plastic Handwheel	S01
Metal Handwheel	S02
Spindle	S03
Aluminium Compressor	S04
CI Compressor	S05
CI Compressor for 214 diaphragm	S06

Bonnet Description	Rubber Diaphragm	PTFE Diaphragm
RHI — Standard Plastic Handwheel	H01	H02
RHI — Standard Metal Handwheel	H03	H04
RHI — Sealed, with Plastic Handwheel	H07	H08
RHI — Sealed, with Metal Handwheel	H09	H10
RHI — Viton Seal and Padlock	H13	H14
RHI — Padlock and Plastic Handwheel	H15	—
RHI — Padlock and Metal Handwheel/Compressor	H17	H18
RHI — GGG 40.3 Plastic Handwheel	H25	—
RHI — SS/EP PES Handwheel	H26	H24
RHI — GGG 40.3 Metal Handwheel	H27	H28
CI Indicator Bonnet	H33	H34
RHI — SS Sealed EP	H45	H46
Gunmetal LG2	H55	—
Non-Rising Gunmetal LG4 and Padlock	H56	—
Non-Rising Gunmetal LG4 with limit open	H57	—

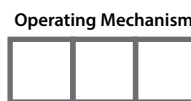
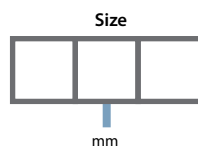
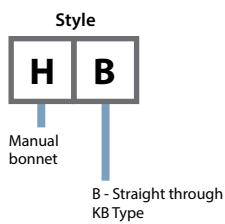

Spares Kits	Code
Plastic Handwheel	S01
Metal Handwheel	S02
Spindle	S03
CI Compressor	S04

Bonnet Description	Code Rubber Diaphragm
RHI — Standard Plastic Handwheel	H01
RHI — Standard Metal Handwheel	H02
CI Indicator Bonnet	H03
RHI — GGG 40.3 Metal Handwheel	H07
Non-Rising Gunmetal LG4 and Padlock	H08

Diaphragm Spares

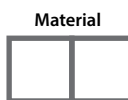
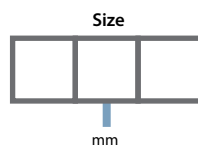
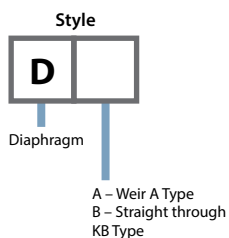

PTFE		Natural Rubber		Butyl	
214/300	P1	AA	A1	300	B1
214/425	P2	Q	A2	300 vac	B2
214/226	P3	Neoprene		Nitrile	
214K/425	P7	HT	N1	C	C1
214S/425	S5	EPDM		C vac	C2
Fluoroelastomer		XA	XA	CSM (formerly Hypalon)	
226	V1	EPM		237	H1
		425	E2	286 fire	H3
		425 vac	E6		

CATALOGUE CODES

Type EC Compact Pneumatic Actuators

Style	Size	Type	Mode of Operation	Diaphragm	Air Connection	Slotted	Limit Stop
A A	<input type="text"/>	C	<input type="text"/>	<input type="text"/>	<input type="text"/>	<input type="text"/>	<input type="text"/>
Diaphragm valve A Type actuator	mm	EC	4 = 4 bar Spring Close 6 = 6 bar Spring Close O = Spring Open D = Double Acting	R = Rubber P = PTFE	B = BSP N = NPT	Y = Yes N = No	N = None O = Limit Open

This side only used when ordering as a spare part.



Type ECX Compact Pneumatic Actuators

Style	Size	Type	Mode of Operation	Diaphragm	Visual Indicator	Limit Stop
A A	<input type="text"/>	X	<input type="text"/>	<input type="text"/>	<input type="text"/>	<input type="text"/>
Diaphragm valve A Type actuator	mm	ECX	F2, F4, G2, G3, G4, G5, H2, H4, H5 = Spring Close OS, OH = Spring Open DS, DH = Double Acting	R = Rubber P = PTFE	Y = Yes N = Only when accessories are used	N = None O = Limit Open

This side only used when ordering as a spare part.



Type EC Actuator OPTI-Set Switchbox Options

Style	Size	Switchbox	OPTI-Set	Conduit Entry	Switch Type	Switch Quantity
V C	<input type="text"/>	B	E	<input type="text"/>	<input type="text"/>	<input type="text"/>
V = Accessory C = EC	mm			O = Metric N = NPT	M1 = V3 Mech. M2 = V3 Mech. Gold Plated M8 = V3 Mech. Gold Plated (ATEX) P2 = ProxSwitch Intrinsically Safe (ATEX) P6 = ProxSwitch 3 Wire NPN P7 = ProxSwitch 3 Wire PNP P8 = ProxSwitch 2 Wire NPN/PNP (5-60Vdc) P9 = ProxSwitch 2 Wire NPN/PNP (5-36Vdc)	1 = One 2 = Two

This side only used when ordering as a spare part.



Type EC and ECX Actuators Module Switchbox Options

Style	Size	Switchbox	Module	Conduit Entry	Switch Type	Switch Quantity	Pneumatic Control	Solenoid Voltage
V	<input type="text"/>	B	M	<input type="text"/>	<input type="text"/>	<input type="text"/>	<input type="text"/>	<input type="text"/>
V = Accessory C = EC X = ECX	mm		O = Metric N = NPT P = PG	M1 = V3 Mech. M2 = V3 Mech. Gold Plated M3 = Mech. DPST M8 = V3 Mech. Gold Plated (ATEX) P2 = ProxSwitch Intrinsically Safe (ATEX) P6 = ProxSwitch 3 Wire NPN P7 = ProxSwitch 3 Wire PNP P9 = ProxSwitch 2 Wire NPN/PNP (5-36Vdc)	1 = One 2 = Two	0 = None 1 = Single/Double Acting 1/8" BSP 2 = Single/Double Acting 1/8" NPT 3 = Single Acting Manifold 1/8" BSP 4 = Single Acting Manifold 1/8" NPT	0 = None 1 = 220/240v AC 50/60Hz 2 = 110/120v AC 50/60Hz 3 = 24v DC 4 = Intrinsically Safe 24v DC (ATEX)	

This side only used when ordering as a spare part.



EC and ECX Actuators i-Vue Switchbox Options

Style	Size	Switchbox	i-Vue Protocol	Solenoid	Elect. Connector	Cable Options
V	<input type="text"/>	B	I	<input type="text"/>	<input type="text"/>	<input type="text"/>
V = Accessory C = EC X = ECX	mm		2E2 = Point to Point A31 = ASI v2.0 A32 = ASI v2.1 DNB = DeviceNet	0 = not required 1 = Aluminium (BSp) 2 = S. Steel (BSp) 3 = Aluminium (NPT) 4 = S. Steel (NPT)	1 = M12 2 = Mini 7/8" 5pin 3 = Cable Gland 4 = Flat Cable	0 = not required [Contact Saunders for details of cable options]

This side only used when ordering as a spare part.



CATALOGUE CODES

Type ES Modular Valve Actuator

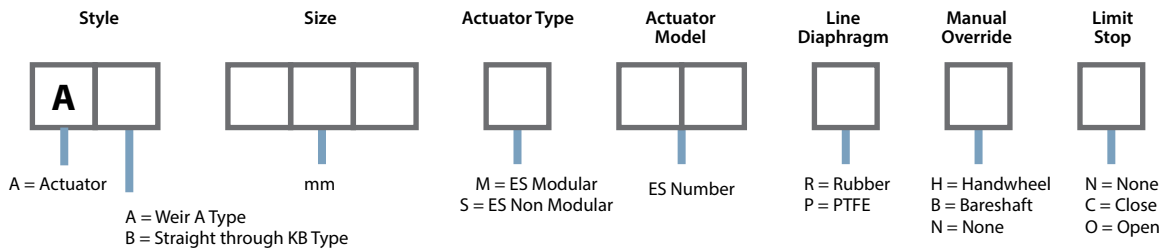

Type ES Modular Actuator 007 Switchbox Options

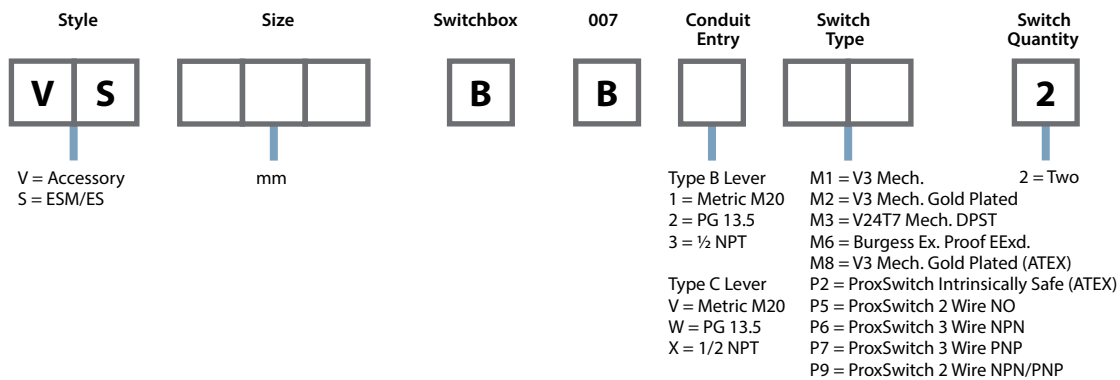

Type ES Actuator Positioner Options

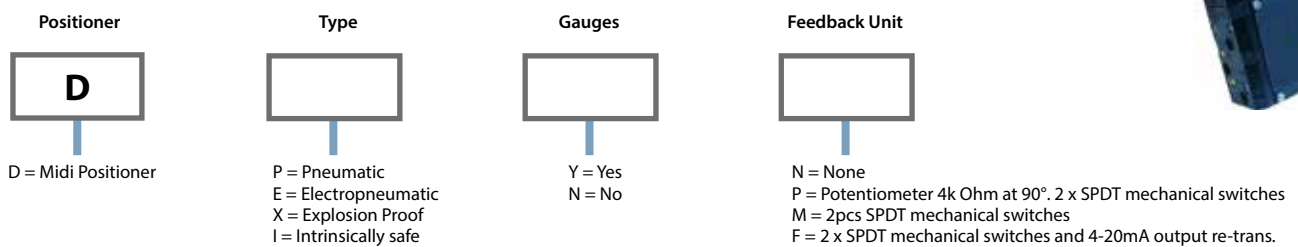

Type ES Actuator Operating Diaphragm Spares

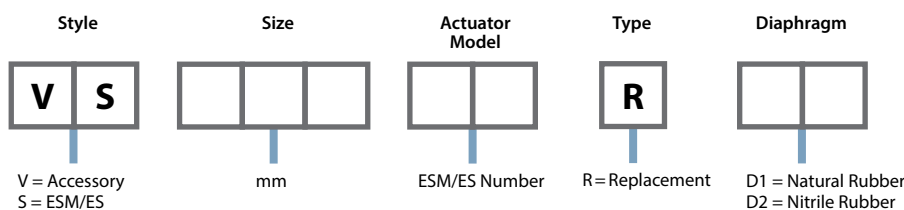

STORAGE, INSTALLATION, OPERATION & MAINTENANCE

Saunders Diaphragm Valves

Key Safety Instructions for Storage, Installation, Operation and Maintenance

Note: For glass lined valves see instruction leaflet 35502

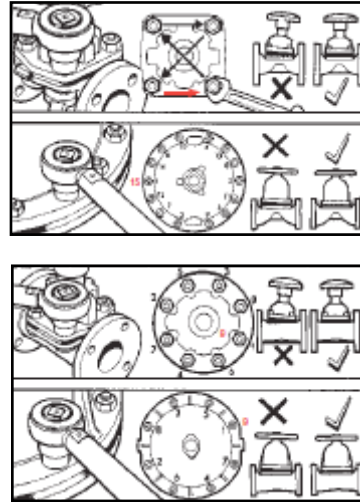
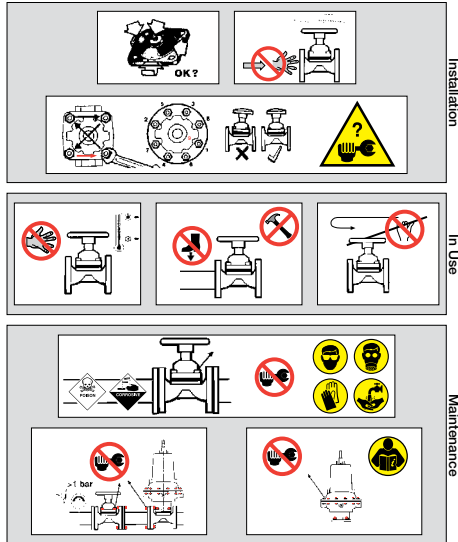

A leaflet detailing key instructions for safe storage, installation, operation and maintenance is supplied with each Saunders diaphragm valve. An excerpt of such a leaflet is shown above.

Storage

Diaphragms

To achieve a long shelf life, we recommend all spare operating and line diaphragms are stored in bags on wooden shelves, away from direct sunlight and ozone (which can be formed by electrical equipment). Leave diaphragms in the provided Saunders® packing until required. To avoid deformation, do not place other articles on top of the diaphragm.

Bodies

Lined bodies supplied as spares will also be fitted with a protective cover across the weir face flange. Keep these protective caps and covers in position until valve/body is installed.

Complete valves

Where possible, store weir type valves (A, and WFB types) in the open position and straight through type valves (K and KB types) in an almost closed position (this retains the line diaphragm in an unstressed position). For power-actuated valves, release spring tension where appropriate. All lined valves are supplied with protective end caps. Special Note: Seal unlined valve ends with paper (especially if stored at ground level on flange face) to reduce the possibility of dirt/moisture ingress.

Check valve and body/lining for:

- correct material
- physical damage
- correct open/closed function
- cleanliness/ freedom from foreign matter
- diaphragm grade for service suitability (or check with Saunders® directly if in doubt)
- body/bonnet fastenings for tightness (see recommended bolting torques)

Installation

Ensure that the valves are properly aligned and the connecting pipework is adequately supported to prevent undue stress. Installing valves near bends, pumps or misaligned pipework should be avoided. According to manufacturing best practices, the valve should be located a minimum of $6 \times D$ the pipe diameter from any bend or pump. Ensure that the intended service conditions are within the pressure/temperature rating of the valve as stated in our catalogue. Where there is an appropriate application standard or code of practice, it is the responsibility of the purchaser to ensure that equipment is compliant.

STORAGE, INSTALLATION, OPERATION & MAINTENANCE

Centralise the diaphragm as follows:

- Fit diaphragm in its natural position i.e. A types – open, KB type – closed
- Mount the bonnet onto the valve body and tighten bolts finger tight.
- Fully close the valve and tighten to 3/4 of final torque value in the correct sequence ensure indent of the first and second lines is the same
- Open valve to allow the diaphragm to regain its natural moulded position i.e. weir types – fully open, straight through types – two turns from fully closed.
- Fasten to recommended torque in the correct sequence.

Before commissioning, the system must be thoroughly flushed through to remove all traces of foreign matter such as rust, pipescale, beads of welding metal etc., which could cause damage to the valve seating faces. Before putting the valve into service, ensure that the bonnet nuts of all valves are correctly adjusted to provide seal to atmosphere (see torque application table).



During the first 24 hours in service, further adjust the bonnet nuts to follow up any relaxation of the diaphragm.

Use

The mechanical efficiency of the handwheel, spindle threads and other bonnet components of Saunders valves is such that normal manual effort is sufficient to give leak-tight closure against the recommended working pressures.

Never use a wrench or pipe lever on the handwheel for closure

Maximum recommended working pressures are based on the assumption that the operator will have reasonable access to the valve. If the valve will not operate in either the open or closed positions, isolate, drain the system and service. Follow the Saunders[®] guide to speeds of operation, for power actuators. Valve opening load is concentrated on the diaphragm stud which can be loosened by a heavy, instantaneous opening or closing load. For this reason, Saunders[®] do not recommend the use of self-fitted direct solenoid operators. Do not overclose the valve.

Excessive closure forces can reduce diaphragm life. Valves sizes DN200 and above are provided with grease nipples for spindle, spindle nut, and bonnet neck bearing lubrication. Lubricate these valves in the open position. Rising handwheel indicator bonnets have a grease reservoir packed for long life. Lubricate spindle and spindle nut of other non-rising handwheel designs during

diaphragm change. Information on recommended lubricants is available from Saunders[®]. Using a special bonnet design complying with the appropriate safety design standards, Saunders[®] can also offer chainwheel operated valves.

Inspection / service / maintenance

Valves should be periodically inspected for corrosion, wear, damage and leakage. This may be performed in line by removal of the bonnet assembly and diaphragm. Cleaning and replacement of the diaphragm, and any damaged part, other than the body, may also be carried out at this time. Full inspection/service/maintenance, including replacement of the body, must be carried out with the valve removed from the line.

Torque Application

This should be carried out at installation or when maintenance is required, using a torque wrench set to the values in the table below. Nuts should be tightened in the correct sequence, as indicated below.



For glass lined products, please refer to the appropriate glass lined figures below.

Size (DN)	Unlined, Plastic & Rubber lined				Glass Lined Product			
	Weir Type 'A'		Straight Through Type 'KB'		Weir Type 'A'		Straight Through Type 'KB'	
	lbf. ft	Nm	lbf. ft	Nm	lbf. ft	Nm	lbf. ft	Nm
8	2	2						
10	2	3						
15/20	4	5	4	5	3	4	3	4
25	5	6	8	11	3	5	6	8
32	6	8	8	11	4	6	6	8
40	10	13	9	12	7	10	7	9
50	18	25	18	25	14	19	14	19
65	26	35	23	30	19	26	17	23
80	37	50	33	45	28	38	25	34
100	29	40	29	40	22	30	22	30
125	33	45	29	40	25	34	22	30
150	59	80	59	80	44	60	44	60
200	72	98	72	98	55	75	55	75
250	80	109	80	109	61	83	61	83
300	92	124	92	124	69	94	69	94
350	92	124	92	124	69	94	69	94
400	92	124						
450	92	124						
500	92	124						

* The specified ¾ of maximum torque value is a non-critical value used in order to hold the diaphragm in position until the valve is opened and the full torque applied.

A link to an animation depicting the correct diaphragm replacement procedure is available on the Saunders section of the Crane ChemPharma & Energy website.



Crane ChemPharma & Energy

Crane Process Flow Technologies Ltd.

Grange Road

Cwmbran, Gwent NP44 3XX

UNITED KINGDOM

Tel: +44 1633 486666

Fax: +44 1633 486777

www.cranecpe.com

CRANE

Crane Process Flow Technologies
SPRL / BV
Avenue Franklin No. 1
Wavre, B-1300, Belgium
Tel: +32 10 8184 44
Fax: +32 10 8184 58

Crane ChemPharma & Energy
Headquarters
4444 Cooper Road
Cincinnati, Ohio 45242
Tel: 513-745-6000
Fax: 513-745-6086

Crane Process Flow Technologies (India) Ltd
Solitaire, 5th & 6th Floor, S.No. 131 / 1+2,
ITI Road, Aundh, Pune - 411007, India
Tel: +91 20 3056 7800
Fax: +91 20 3056 7812



brands you trust.



CPE-SAUNDERS OV-BU-EN-A4-01-2015-13

Crane Co., and its subsidiaries cannot accept responsibility for possible errors in catalogues, brochures, other printed materials, and website information. Crane Co. reserves the right to alter its products without notice, including products already on order provided that such alteration can be made without changes being necessary in specifications already agreed. All trademarks in this material are property of the Crane Co. or its subsidiaries. The Crane and Crane brands logotype, in alphabetical order, (ALOYCO®, CENTER LINE®, COMPAC-NOZ®, CRANE®, DEPA®, DUO-CHEK®, ELRO®, FLOWSEAL®, JENKINS®, KROMBACH®, NOZ-CHEK®, PACIFIC VALVES®, RESISTOFLEX®, REVO®, SAUNDERS®, STOCKHAM®, TRIANGLE®, UNI-CHEK®, WTA®, and XOMOX®) are registered trademarks of Crane Co. All rights reserved.