



PHASE
Butterfly Valves

DOUBLE OFFSET BUTTERFLY VALVES

Body design	WAFER type with through holes LUG type with threaded holes
Nominal size	DN50 - DN600
Working pressure	16 bar / 25 bar / 40 bar / 50 bar
Flange connection	PN6 / PN10 / PN16 / PN25 / PN40 Class 150 / Class 300
Working temperature	-55 °C / +325 °C *)
Working media	Waste / Supply water Potable water Hot industrial water Crude oil Petroleum products Fuel / Oil / Oil derivatives Pulp / Paper stock Natural gas Coke oven gas Stack gas Steam / Condensate Air Bitumen (asphalt)
Tightness	Class A **)
Features	Excentric seat design Bi directional tightness (RS design) SIL2 / SIL3 ***) certification ATEX performance ***) TA-Luft stuffing box ***)

*) higher working temperatures
upon request according to
the material performance
of the valve body

**) Metal-Metal seat tightness
Class C



SERIES 2E

energy line

GENERAL VALVE DESCRIPTION

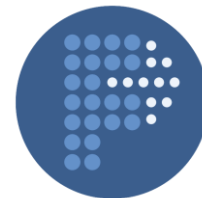

The 2E-series double offset butterfly valves

are industrial fittings intended for full opening or closing flow. They may be also used for a rough flow control. The valves are designed for operation with very hard industrial conditions demanding safety, reliability and minimum maintenance like for example:

- nuclear energy industry
- water treatment
- gas pipe-works
- chemical industry
- metallurgy (and heavy industry in general)
- pulp and paper-making industry
- shipbuilding industry
- oil and petrochemical industry
- heat recovery, steam heating
- processing hydrocarbons
- fuel storage in aviation industry

Basic properties

- double offset design
- eccentric disc position in the body, precise connection of the disc with the stem and pivot, exact shaft and pivot bearing in the slide bushings
- split sealed stem - bigger Kv
- high efficiency of opening and closing valve
- easy operation
- easy assembly and installation
- vacuum max. 0,01 bar abs. (version R-PTFE)
- standardized top flange according to EN ISO 5211 enabling mount various types of actuator (electric, pneumatic, hydraulic)
- ATEX certified for explosive atmosphere
- option: TA-Luft sealed valve - stem is sealed with a special graphite gland



Type designation

5 5 9 0 B 100

Nominal size (DN)

Body design

B - AFER W body type with th holes reared
T - LUG body type with tapped holes

Disc material

0 - stainless steel 1.4408 (CF8M)
stainless steel 1.4409 (ASTM A351 CF3M)
stainless steel 1.4027 (ASTM CA-40)

Seat material

9 - R-PTFE (PTFE reinforced by 25% glass fibre)
8 - FIRE SAFE (R-PTFE + INCONEL)
7 - INCONEL 718 2.4668

Body material

6 - low carbon steel 1.1156 (A352 LCC)
5 - carbon steel 1.0625 (A216 WCB)
4 - stainless steel 1.4408 (A351 CF8M))

Series designation

Series 2E

Standards

Leak test

Design „R-PTFE”

Design „ Fire Safe”

EN 12266-1, Class A
ISO 5208, Class A
API 598

Design „Metal-Metal”

DN 50-DN125
EN 12266-1, Class C
ISO 5208, Class C
API 598

Face to face length

EN 558, Series 20
ISO 5752, Series 20
API 609, Table 3

ATEX performance

according to 2014/34/EU

Flange connection

EN 1092-1, 2

Top flange

EN ISO 5211

Working standard

EN 593

Marking

EN19

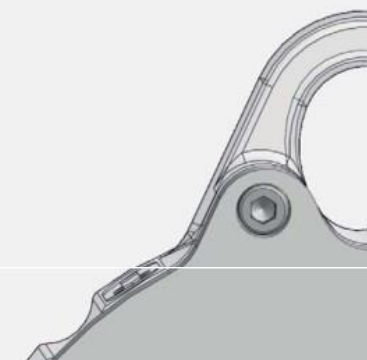
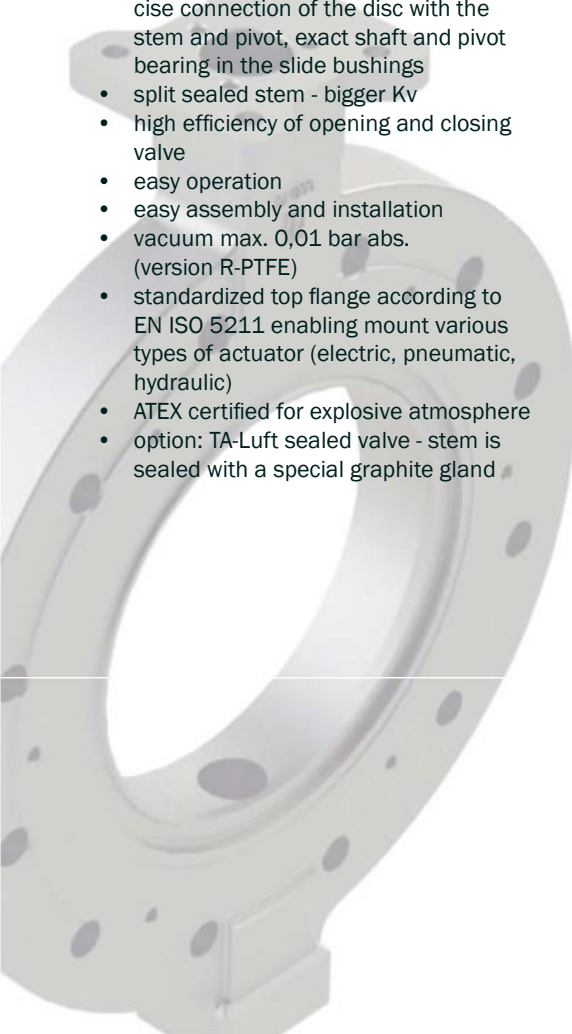

VALVE MODELS



B
WAFER
DESIGN



T
LUG
DESIGN



Standard line
DN50-DN400
Bi-directional
line (RS design)
DN50-DN600

B
WAFER
DESIGN



T
LUG
DESIGN



DN50-DN125

DN150-DN600

Advantages of double offset valves

- split stem allows higher Kv/Cv values
- lower pressure loss
- gas pipe-works
- guaranteed tightness in both directions at nominal working pressure (RS version)
- sealing ring and seat come to contact only nearly after the valve is entirely shut
- low closing torque
- the seal guarantees perfect upper stem tightness
- water and air tightness
- actuator connection can be done by bracket or the stem can be extended if connected to special actuator types

Quality control

- Our valve production facilities are certified in accordance with ISO 9001:2015 (14001, 45001) quality control standards
- tightness test procedures according to standards EN 12266-1, ISO 5208, ANSI/FCI 70-2, API598
- production in accordance with the Pressure Equipment Directive 2014/68/EU (Module H)
- the possibility of issuing inspection certificate 3.1, 3.2
- all the actuators are adjusted and tested while assembled

Split stem/
Better
flow rate

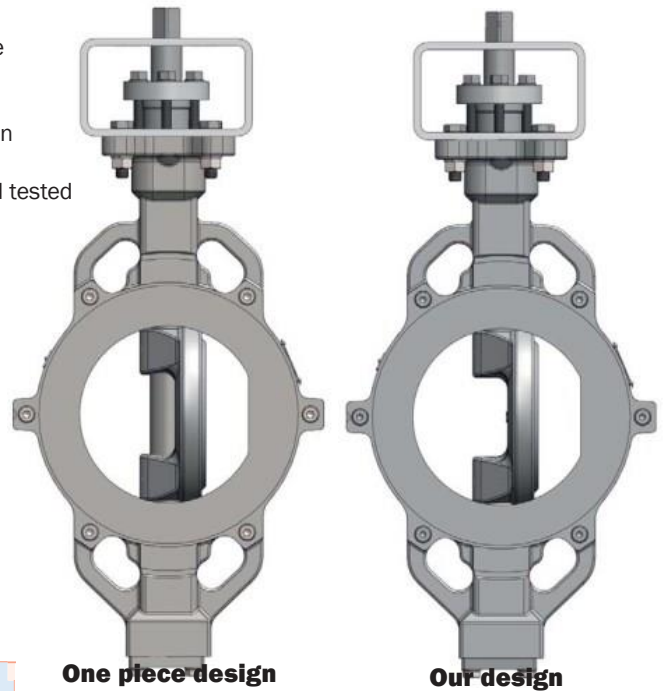

One piece design

Our design

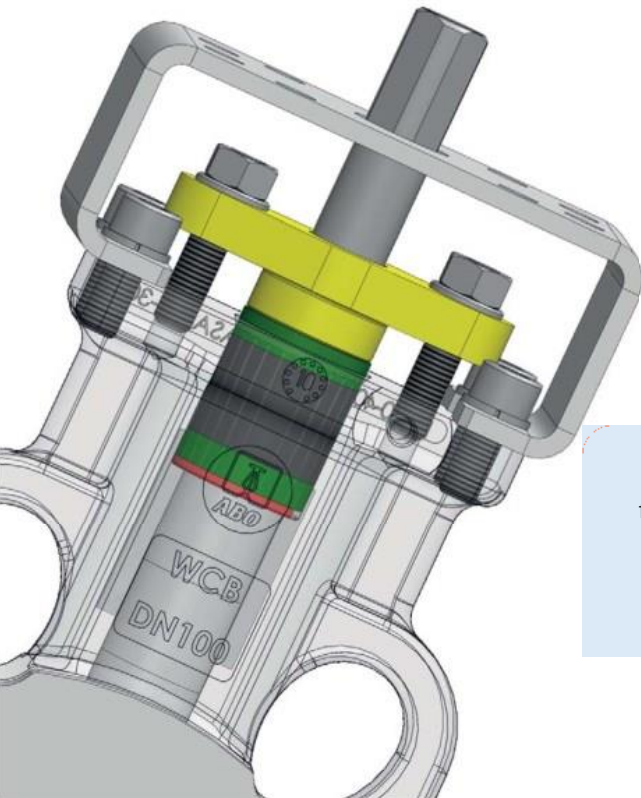

The stem seal with TA-LUFT certification for perfect tightness of pollutants into the ambient air (upon request)

DESIGN ADVANTAGES



Double offset

- the double offset design provides a safe function and tightness even after a sudden temperature or pressure change. It reduces seat wear and ensures perfect tightness. The first offset **(1)** shifts the axis of the rotation off the sealing surface and thus provides tightness between the seat and the sealing ring around the entire disc circumference. The second offset **(2)** moves the the axis of the disc rotation off the valve (pipeline) axis and thus releases the ring from the seat after a few degrees of opening movement. The reason of the second offset is to quickly relieve the seal from compression between the disc and the seat
- the design extends the seal lifetime and the torques are lower. When shutting valve, the rotating movement is changed to the linear one and the disc is effectively pressed into the seal. The design also prevents undesirable agglomerating e. g. undissolved substances in the area of disc and seal contact.

- (1)** - stem axis is off the sealing surface
(2) - stem offset off the pipeline axis

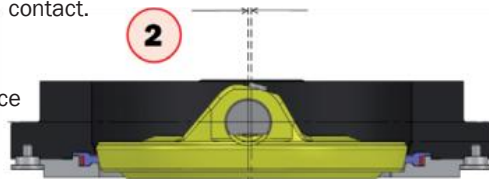

Stem and seal (3)

- two-piece stem** - thanks to the split stem the valve attains higher values of Kv/Cv and related low pressure loss
- adjusting seal according to the customers' requirements** - the seal can be tightened to the parameters prescribed by customers. Thus maximum tightness can be achieved around the stem and the actuation torque for low-pressure applications can be decreased.
- adjustable seal** - enables easy access to final adjustment of the seal without dismantling the actuator
- stem assembly** - upper and lower bushings made from TP Igus provides high abrasion resistance and prolongs valve lifespan

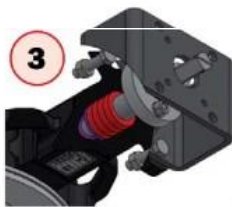

- extended neck** - enables to insulate piping incl. the valve
- easy service and seal replacement** - easy assembly and replacement
- top flange according to ISO 5211** - enables to directly install a manual handle or an actuator

Seal design

- R-PTFE** - suitable seal geometry ensures full tightness and a high number of cycles. The PTFE seal is reinforced with 25% glass fibres, reducing wear and increasing valve thermal stability. Longer lifespan of the valve and lower maintenance demand are guaranteed.
- end-stops** - are designed to avoid overrunning the maximum allowable position of the disc. Thus the seal is not damaged nor overloaded and the valve lifespan is extended **(4) (5)**.

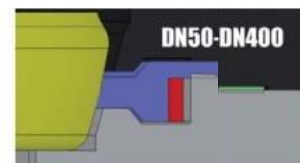

MATERIAL PERFORMANCE

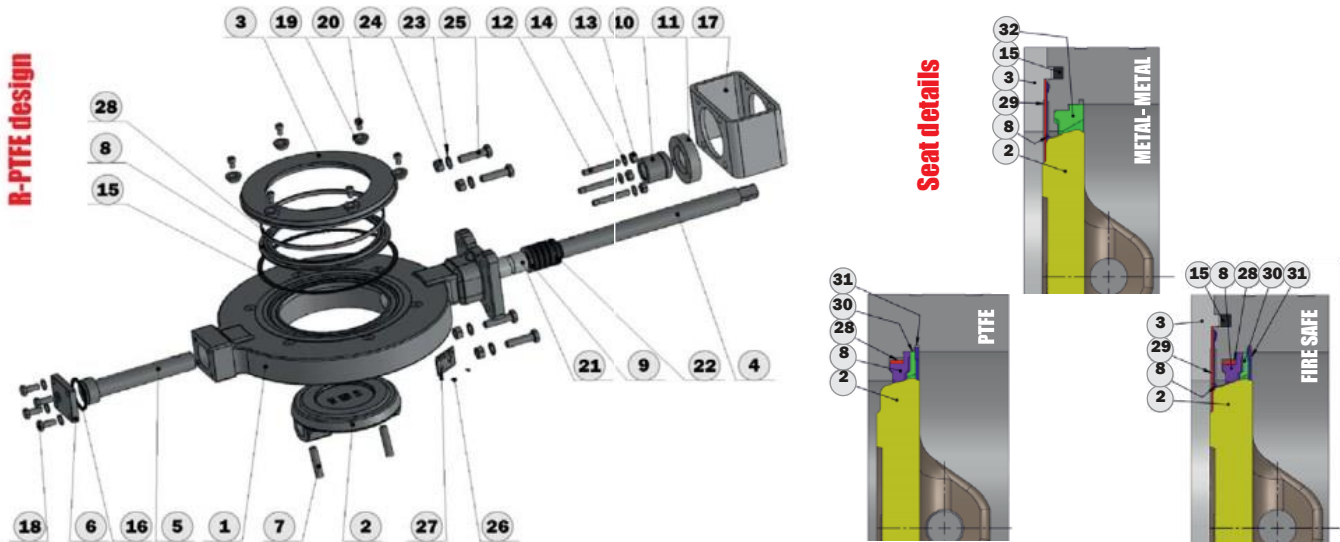

Item	Name	Material
1	Body	6 - low carbon steel 1.1156 (A352 LCC) 5 - carbon steel 1.0625 (A216 WCB) 4 - stainless steel 1.4408 (A351 CF8M)
2	Disc	DN50-125: stainless steel 1.4409 (ASTM A351 CF3M / CF8M) DN150-600: 55xx: stainless steel 1.4027 (ASTM CA-40) 54xx, 56xx: stainless steel 1.4408 (ASTM A351 CF8M)
3	Pressure flange	Carbon steel 1.0425 Stainless steel 1.4404 (AISI 316L)
4	Stem	54XX, 56XX: stainless steel 1.4462 55XX: stainless steel 1.4021 (AISI 420)
5	Pivot	DN50-125: stainless steel 1.4404 (AISI 316L) DN150-600: stainless steel 1.4021 (AISI 420)/1.4462
6	Cover	DN50-125: - DN150-600: carbon steel 1.4025 / stainless steel 1.4401 (AISI 316)
7	Pin	DN50-125: - 54XX, 56XX DN150-600: stainless steel 1.4462 55XX DN150-600: stainless steel 1.4021 (AISI 420)
8	Seat	XX70 DN50-125: INCONEL 718 2.4668 XX80: FIRE SAFE (R-PTFE + INCONEL) XX90: R-PTFE (PTFE reinforced by 25% glass fiber)
9	Washer	Stainless steel 1.4404 (AISI 316L)
10	Stuffing box	DN50-125: - 54XX, 55XX DN150-600: stainless steel 1.4401 (AISI 316) 56XX DN150-300: stainless steel 1.4401 (AISI 316) 56XX DN350-600: stainless steel 1.4404 (AISI 316L)
11	Sealing flange	54XX, 55XX, 56XX DN50-125: stainless steel 1.4308 (CF8) 54XX, 55XX, 56XX DN150-600: stainless steel 1.4301 (AISI 304)
12	Bolt	Stainless steel A4
13	Nut	Stainless steel A4

Item	Name	Material
14	Washer	Stainless steel A4
15	Flange sealing	Graphite min. 98%
16	Cover seal	Graphite
17	Bracket	DN50-125, 500, 600: carbon stell 1.0553 DN150-400: carbon stell 1.0576
18	Bolt	Stainless steel A4
19	Retaining sleeve	Stainless steel 1.4404 (AISI 316L)
20	Bolt	Stainless steel A4
21	Bushing	Xx70, Xx80: stainless steel 1.4404 (AISI 316L) + nickel plated XX90: TP IGUS
22	Sealing	Graphite min. 98%
23	Washer	Stainless steel A4
24	Nut	Stainless steel A4
25	Bolt	Stainless steel A4
26	Rivet	Stainless steel A4
27	Label	Stainless steel
28	Seat O-ring	Stainless steel 1.4404 (AISI 316L) - only for „R-PTFE“ and „FIRE SAFE“ version
29	Sealing	INCONEL - only for „METAL-METAL“ and „FIRE SAFE“ version
30	Support ring	Stainless steel 1.4404 (AISI 316L)
31	Retaining ring	Stainless steel 1.4401
32	Support ring	Stainless steel 1.4404 (AISI 316L)

Working pressure max. **Temperature rating *)**
R-PTFE seat - tightness A -29 °C do 200 °C (R-PTFE) - 5590

DN50-DN100: 50 bar 55 °C do 325 °C (Inconel) - 5470

DN125-DN200: 40 bar

DN250-DN450: 25 bar **Coating**

Metal-Metal seat - tightness C RAL 9005 - standard
 Coating resistant to high temperatures (up to +600 °C)

Fire Safe seat - tightness A
 DN50-DN125: 25 bar upon request

*) depending on the material performance of the valve body (will be specified - please consult with Factory)

Other material performance on request. To select a suitable material solution please contact our factory. Maximum temperatures for each seats are only permitted for specific media and short-term use.

OPERATING TORQUES / FLANGE CONNECTION



Operating torques (Nm) vs. working pressure (bar) R-PTFE seat (standard line DN50-DN400)

DN	50	65	80	100	125	150	200	250	300	350	400	450	500	600
NPS	2"	2 1/2"	3"	4"	5"	6"	8"	10"	12"	14"	16"	18"	20"	24"
PS 16 bar	19	35	50	77	110	145	278	567	650	1378	2248	2569	3090	4300
PS 25 bar	22	45	58	79	120	185	366	732	900	1900	3483	3925	5340	6250
PS 40 bar	32	53	62	90	150	242	485							
PS 50 bar	25	60	65	105										

Operating torques are mentioned without safety reserve.

Metal-metal seat and Fire Safe seat

DN	50	65	80	100	125
NPS	2"	2 1/2"	3"	4"	5"
P_{MAX} 16 bar	50	70	100	150	220
P_{MAX} 16 bar	50	70	100	150	220

Operating torques are mentioned without safety reserve

Installation between flanges DN50 - DN600

DN	50	65	80	100	125	150	200	250	300	350	400	450	500	600
NPS	2"	2 1/2"	3"	4"	5"	6"	8"	10"	12"	14"	16"	18"	20"	24"
PN6	•	•		•	•	•	•	•	•	•	•	X	X	X
PN10														
PN16														
PN25														
PN40													X	X
ANSI150														
ANSI300										X	X	X	X	X
JIS 10K			•		•		•		•	X	•	•		
JIS 16K		•	•			•				•				

For Lug type (T) installation, please specify in the inquiry

Standard

•

Upon request

X

Impossible

KV (CV) coefficient

DN	50	65	80	100	125	150	200	250	300	350	400	450	500	600
NPS	2"	2 1/2"	3"	4"	5"	6"	8"	10"	12"	14"	16"	18"	20"	24"
KV	87	148	312	456	750	1125	1950	3100	4510	6120	8605	9419	11674	16914
CV	102	173	364	532	876	1313	2277	3619	5265	7145	10046	10926	13542	19620

PRESSURE AND TEMPERATURE CURVES



Body A351 CFM / PTFE seat

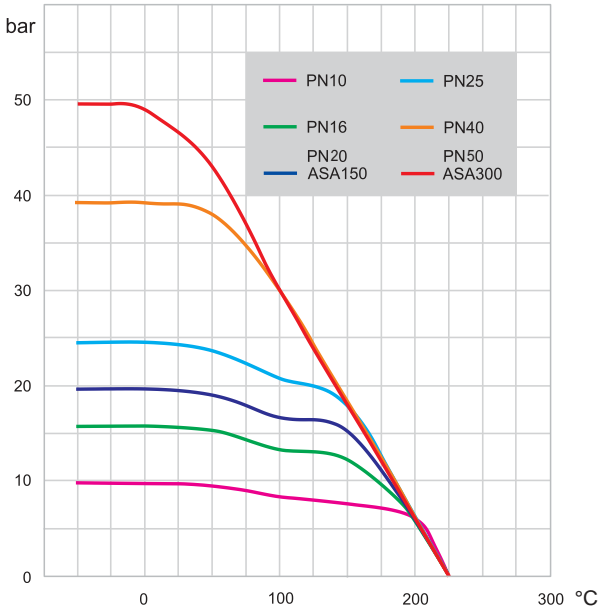

Body A216 WCB / PTFE seat

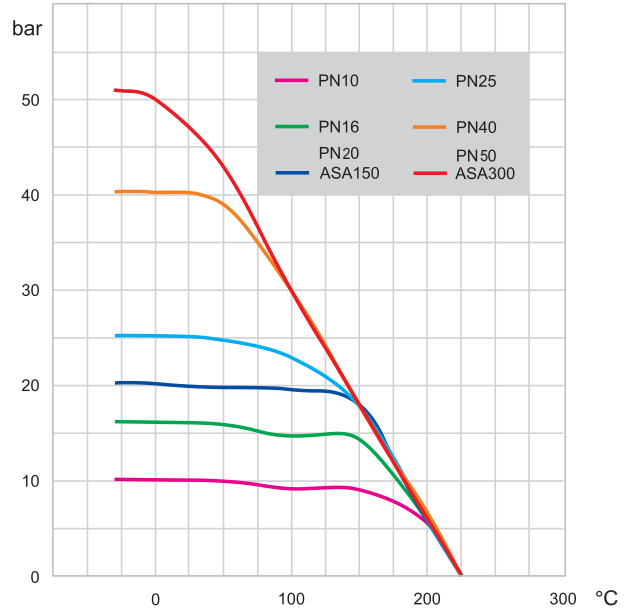

Body A216 WCB / Metal-Metal seat

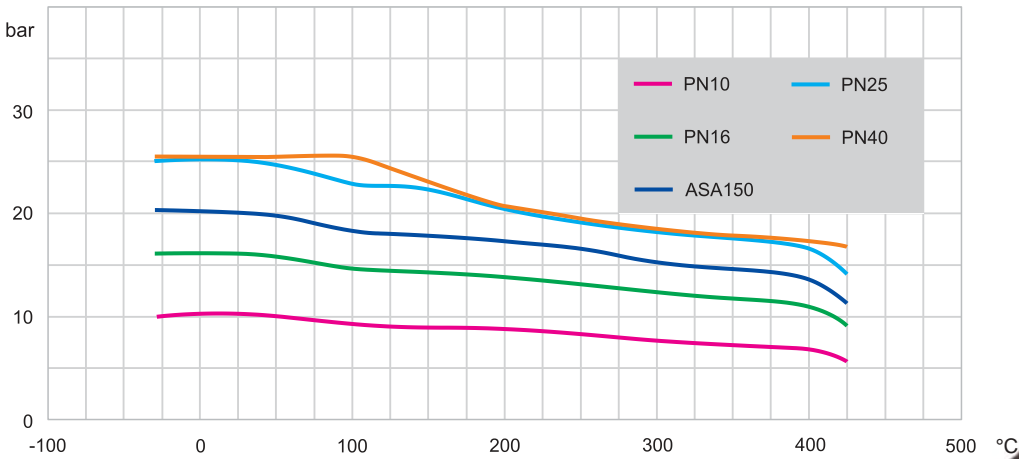

Body A351 CFM / Metal-Metal seat

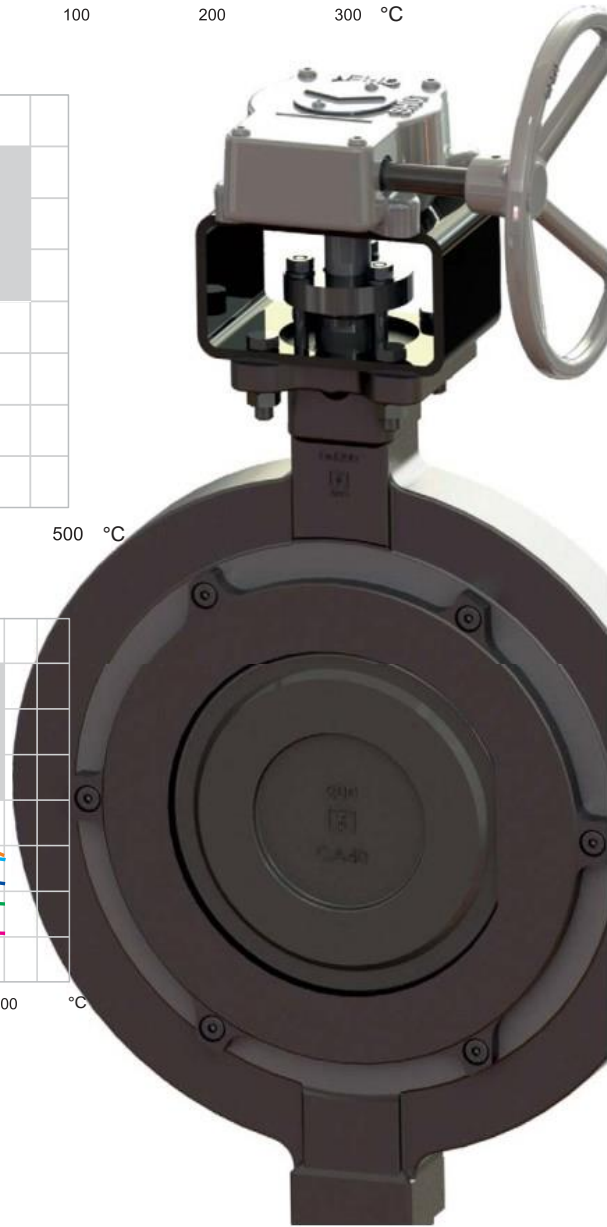
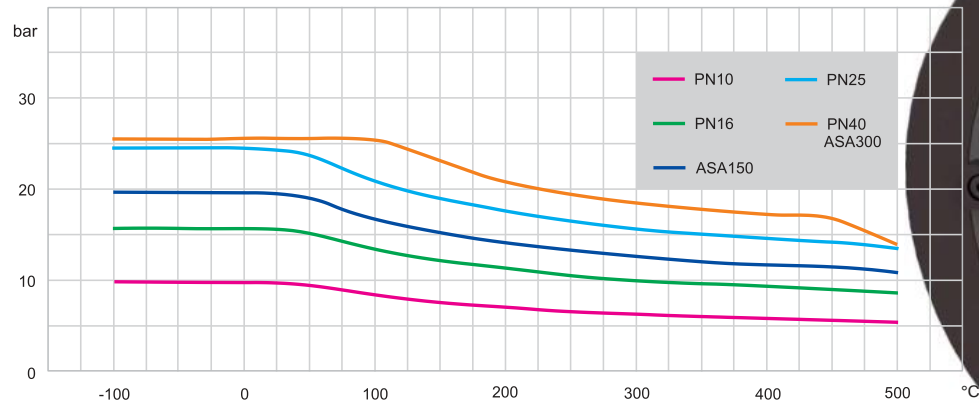

VALVE ACTUATION

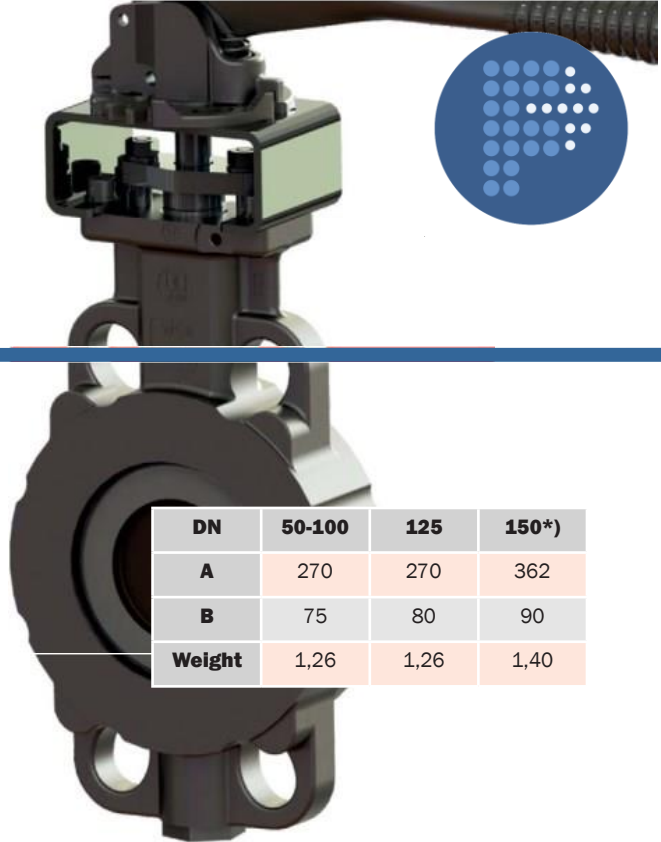

All the our valves can be equipped with hand levers (up to DN150), worm gears, pneumatic and electric actuators. The upper flange design according to the standard ISO 5211 enables to directly assemble actuators on valves.

Handlever

For manual actuation our valve offers carbon steel lever suitably painted to improve resistance to corrosion and abrasion. Stainless lever on request. Top flange connection according to ISO standards F07 for DN50 to DN125 and F10 for DN150. Controlled lever on request. The levers can be equipped with a padlock to ensure an optimized position, can be equipped with end position sensors.

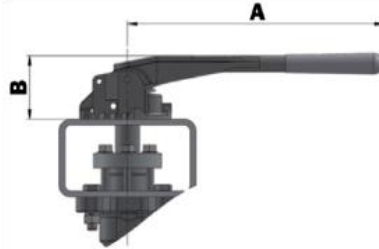

DN	50-100	125	150*)
A	270	270	362
B	75	80	90
Weight	1,26	1,26	1,40

Worm gear with handwheel

Manual gearbox housing is made from cast iron with suitable surface treatment and protection degree class IP 67. Self-locking design of the worm gear enables both to adjust basic positions open/shut and to control (throttle) media flow. The worm gearbox is simply actuated by means of a handwheel of a suitable diameter. End-limit positions of the worm gearbox are set by means of stop screws. The gearbox can be equipped with a lockable system secured by a padlock. Another way how to handle worm gearbox is using a chain. The worm gearbox as well as the hand lever can be completed with end-limit position sensors



DN	PS	ISO FLANGE	SHAFT	A	B	C	D	E	F	Kg
50	50	F07	14x14	127	46	139	59	141	200	2,9
65	50	F07	14x14	127	46	139	59	141	200	2,9
80	50	F07	14x14	127	46	139	59	141	200	2,9
100	50	F07	14x14	127	46	139	59	141	200	2,9
125	40	F07	14x14	127	46	139	59	141	200	2,9
150	40	F10	17x17	133	59	154	60	155	200	2,9
200	40	F10	17x17	133	59	154	62	155	200	2,9
250	25	F12	22x22	287	67	275	181	319	500	10
300	25	F14	27x27	287	67	275	181	319	500	10
350	25	F16	27x27	352	78	275	219	381	600	13
400	25	F16	36x36	398	110	346	245	454	700	24,6
450	25	F16	Ø55	408	142	400	120	480	700	50
500	25	F25	Ø64	255	142	378	142	330	400	40
600	25	F25	Ø75	363	175	429	175	440	500	50

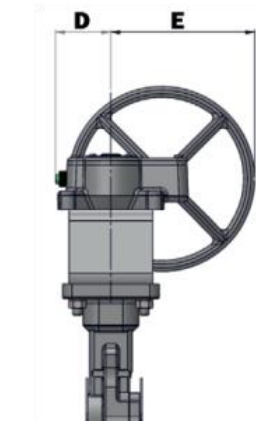

Actuators

Pneumatic actuators

Pneumatic actuators our Series 95 can be assembled to valves in two options: single-acting or double-acting.

Pneumatic actuators

Electric actuators our Series 97 are designed quarter-turn. Electric actuators can be installed on our valves for voltages of 24 V, 230 V or 400 V.

Special actuators types

Valves are equipped with special actuator types from major world suppliers (Auma, Regada, Valpes, etc.).



BASIC DIMENSIONS

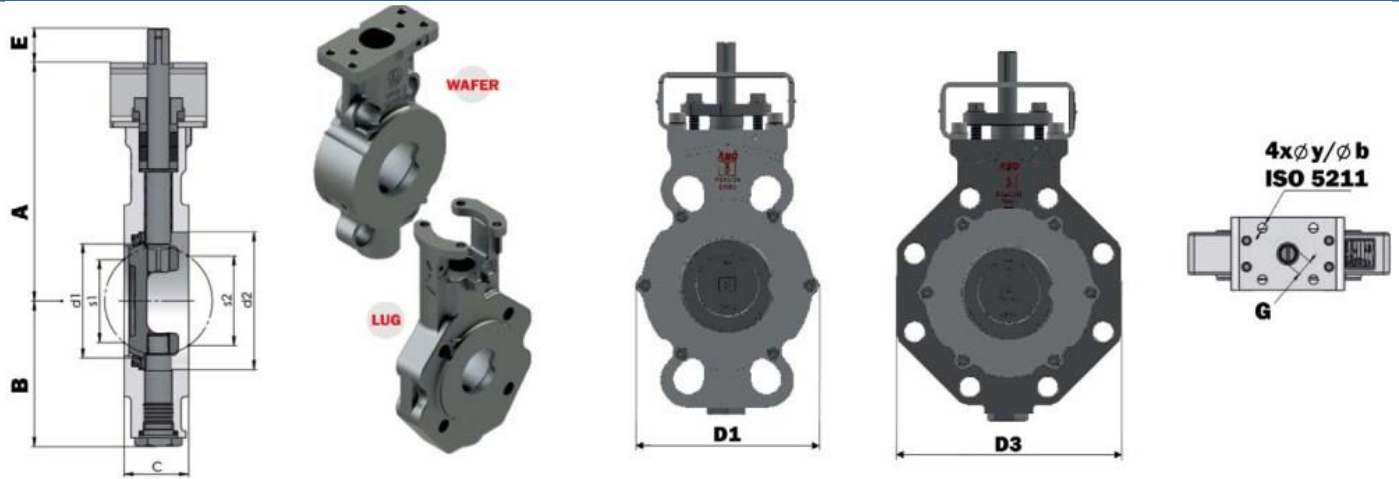

DN	d1	d2	A	B	C	D1	D2	s1	s2	E	G	ISO FLANGE	y	b	DESIGN B (kg)	DESIGN T (kg)
50	49	68	163	93	44	104	154	12	37	25	14	F07	9	70	5,1	7,3
65	65	82	170	100	47	123	178	39	55	25	14	F07	9	70	5,8	9,0
80	81	100	174	106	47	140	196	65	72	25	14	F07	9	70	6,8	10,1
100	100	123	206	123	53	163	225	85	91	25	14	F07	9	70	8,5	12,2
125	123	146	215	137	57	193	260	113	110	25	14	F07	9	70	11,8	16,5

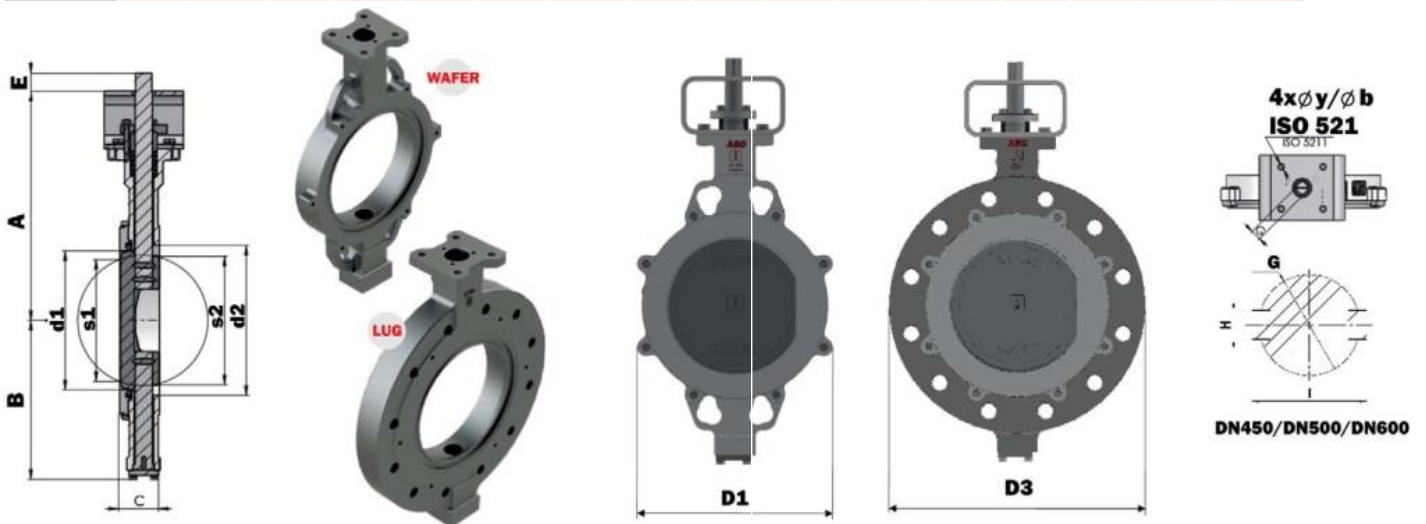

DN	d1	d2	A	B	C	D1	D2	s1	s2	E	G	ISO FLANGE	y	b	DESIGN B (kg)	DESIGN T (kg)
150	146	155	307	214	57	252	318	136	143	25	17	F10	11	4	21	28
200	194	204	339	246	61	307	381	185	193	31	22	F10	11	4	29	41
250	240	259	395	275	69	349	450	224	236	31	22	F12	13	4	46	70
300	287	309	460	313	79	393	521	270	284	31	27	F14	17	4	67	105
350	313	342	508	355	92	448	577	300	308	45	27	F16	22	4	91	140
400	364	405	556	402	103	542	657	342	360	58	36	F16	22	4	132	211
450	420	450	567	395	114	565	-	400,2	419	80	ø55/16 /62,6	F16	22	4	165	-
500	452	500	625	431	127	593	707	434	454	100	ø64/18 /72,4	F25	17,5	8	241	282
600	547	600	698	491	154	695	830	524	546	110	ø75/20 /84,2	F25	17,5	8	367	

BIDIRECTIONAL TIGHTNESS / -RS- VERSION (DN50-DN600)



Butterfly valves of 2E series (RS version) are delivered in nominal sizes of DN50 to DN600. Their make provides bidirectional tightness of the valve. On the circumference the valve is sealed with a special RTFE seal filled with 25% glass fibres and silicone filling.

Body material

- carbon steel 1.0625 (A216 WCB)
/ 1.0425 (P265 GH)
- low carbon steel 1.1156 (A352 LCC)
/ 1.0566 (P355 NL1)
- stainless steel 1.4409 (CF3M)
/ 1.4401 (AISI 316)

Disc material:

- DN50-DN125
stainless steel 1.4409 (ASTM A351 CF3M / CF8M)
- DN150-600:
55xx: stainless steel 1.4027 (ASTM CA-40)
54xx, 56xx: stainless steel 1.4408
(ASTM A351 CF8M)

Valve features

- bidirectional tight and control butterfly valve with all-stainless disc
- double offset design
- sizes DN50 to DN600
- tightness class A (EN 12266-1)
- better flow rate due to split stem
- the seat is adapted to large temperature changes
- delivered for manual, electric or pneumatic control
- suitable for heat and power plants, steam and hot water pipework systems
- the valves may be delivered with a special surface protection

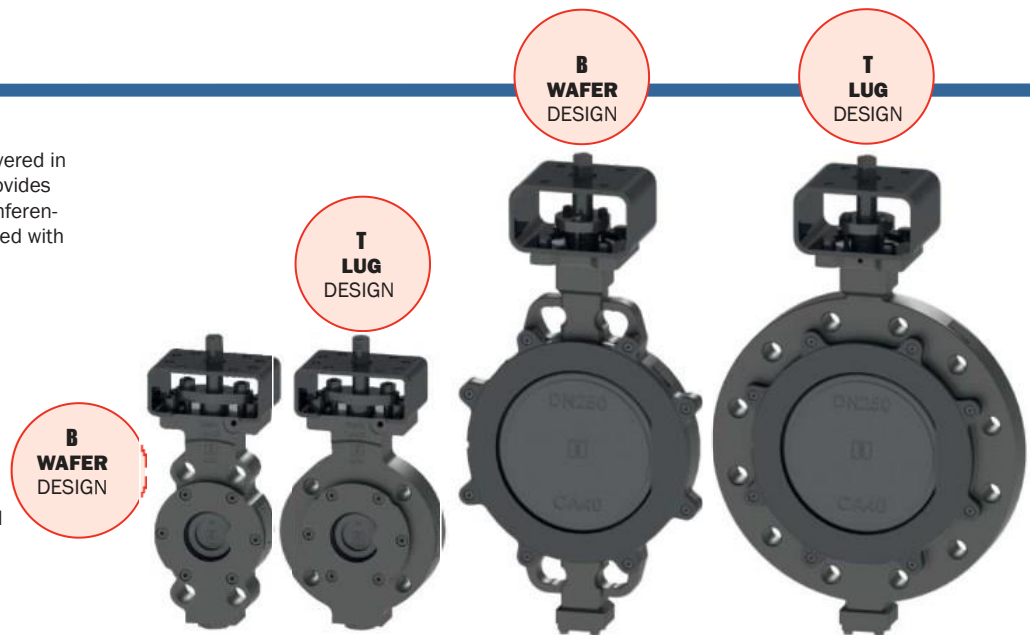

DN50-DN125

DN150-DN600

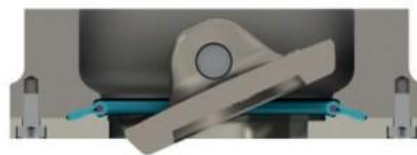

Head Office:

Heap & Partners Ltd
Canada Works, Corporation Road
Birkenhead, Wirral, CH41 8FA
United Kingdom

Tel: +44 (0) 151 488 7222

email: info@heaps.co.uk

Web: www.phasevalves.com

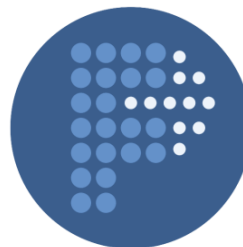

PHASE
Butterfly Valves

Czech Republic

ABO valve, s.r.o.
Dalimilova 285/54
783 35 Olomouc

The technical information described in this leaflet is tentative and for general use only and does not constitute a recommendation or guarantee for any specific service or application requirement. Please consult factory for specific requirements and material selection for your intended application. The right to change or modify product design or product without prior notice is reserved. Phase Butterfly Valves accepts no liability for damages caused by bad interpretation or use of the information included in this brochure.

Valid from: 8/2024